

REVISIONS					
P	LTN	DESCRIPTION	DATE	DWN	APVD
B3		REVISED PER ECO-17-017569	04DEC2017	KP	GM
B4		REVISED PER ECO-19-001038	22JAN2019	JMS	GM
B5		REVISED PER ECO-19-016189	06NOV2019	JMS	WW
B6		REV PER ECO-21-002808	23MAR2021	RGV	WW

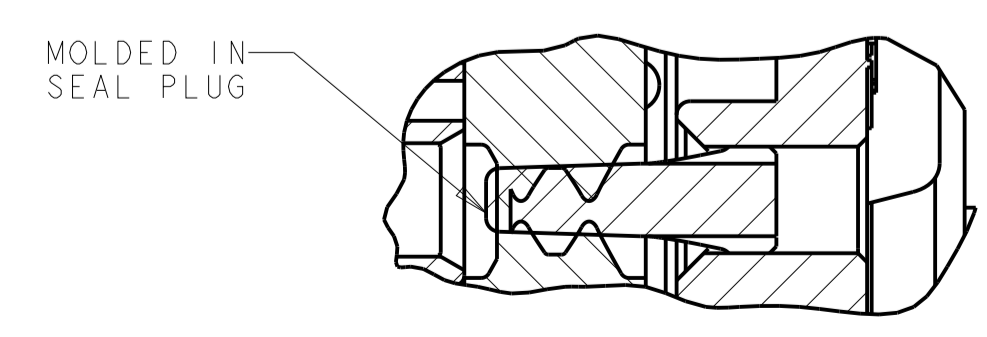
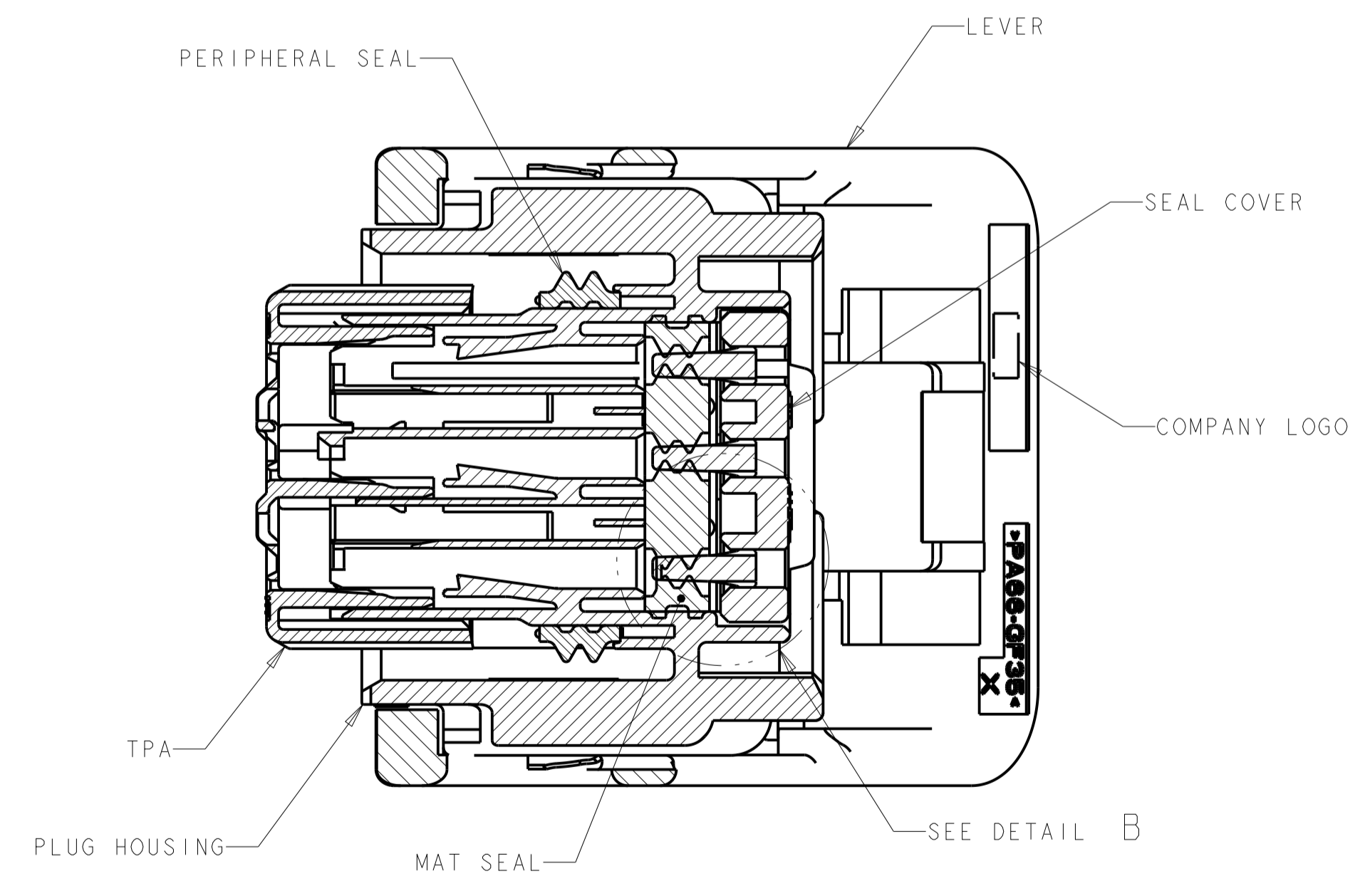
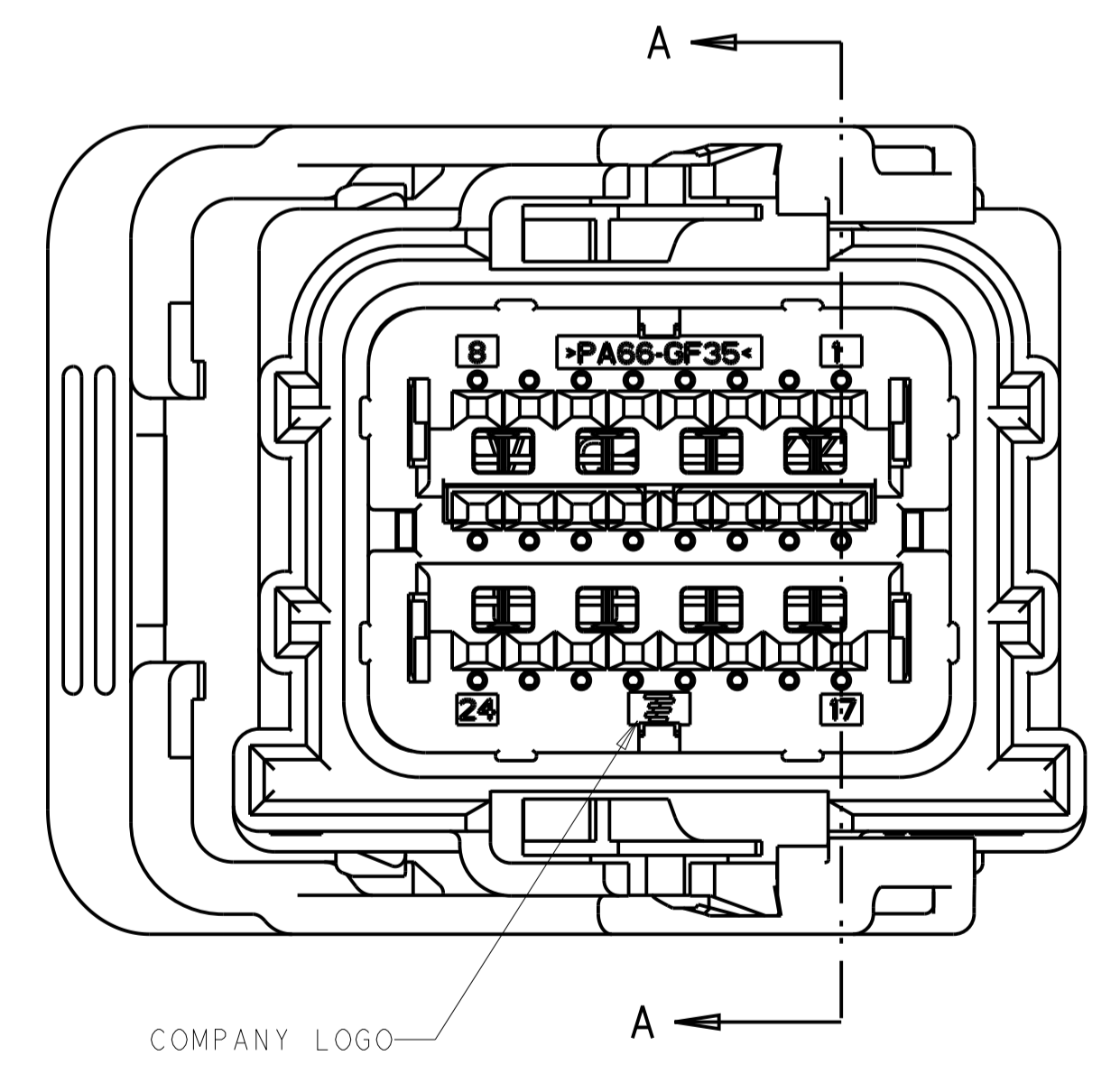
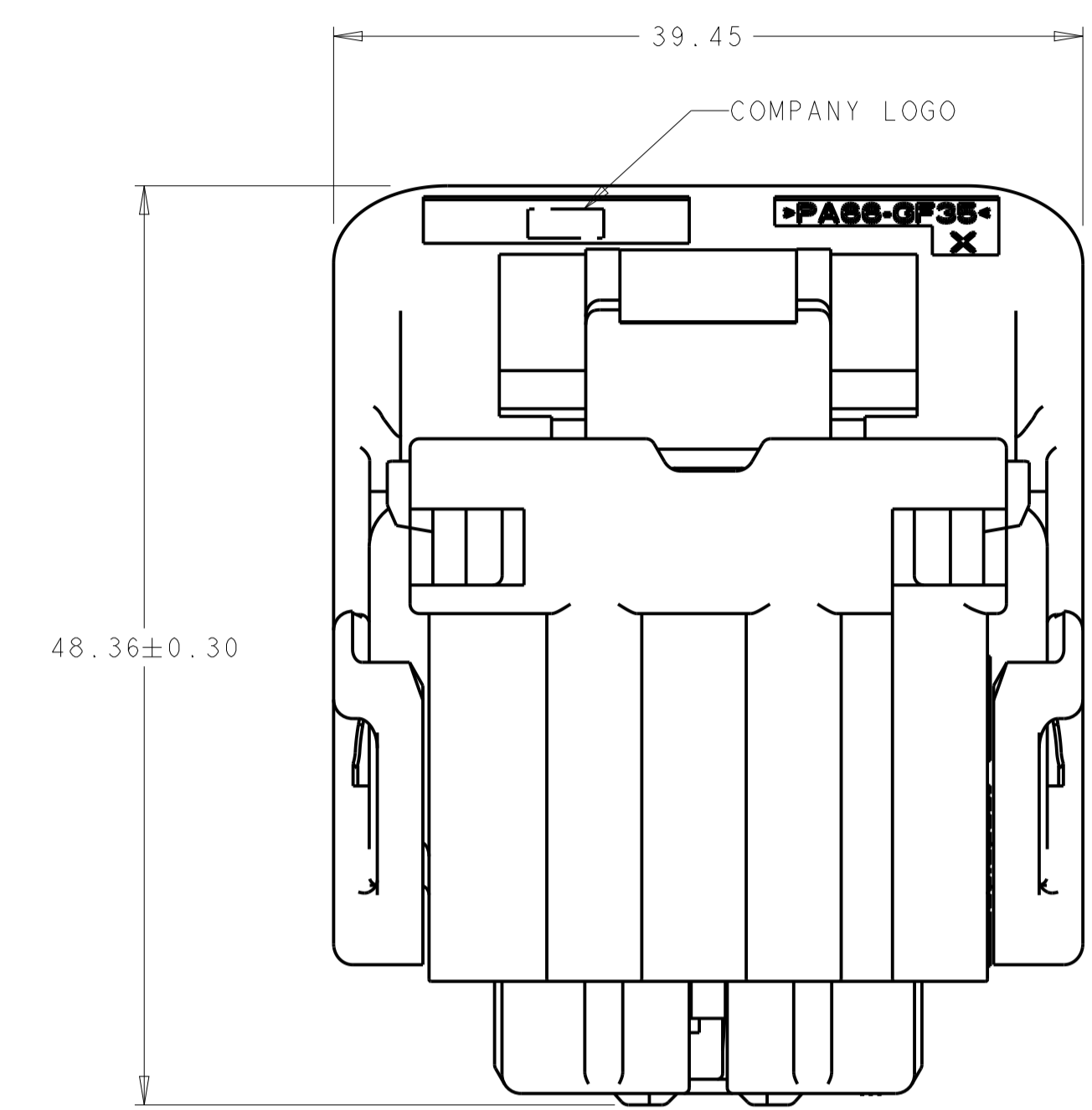
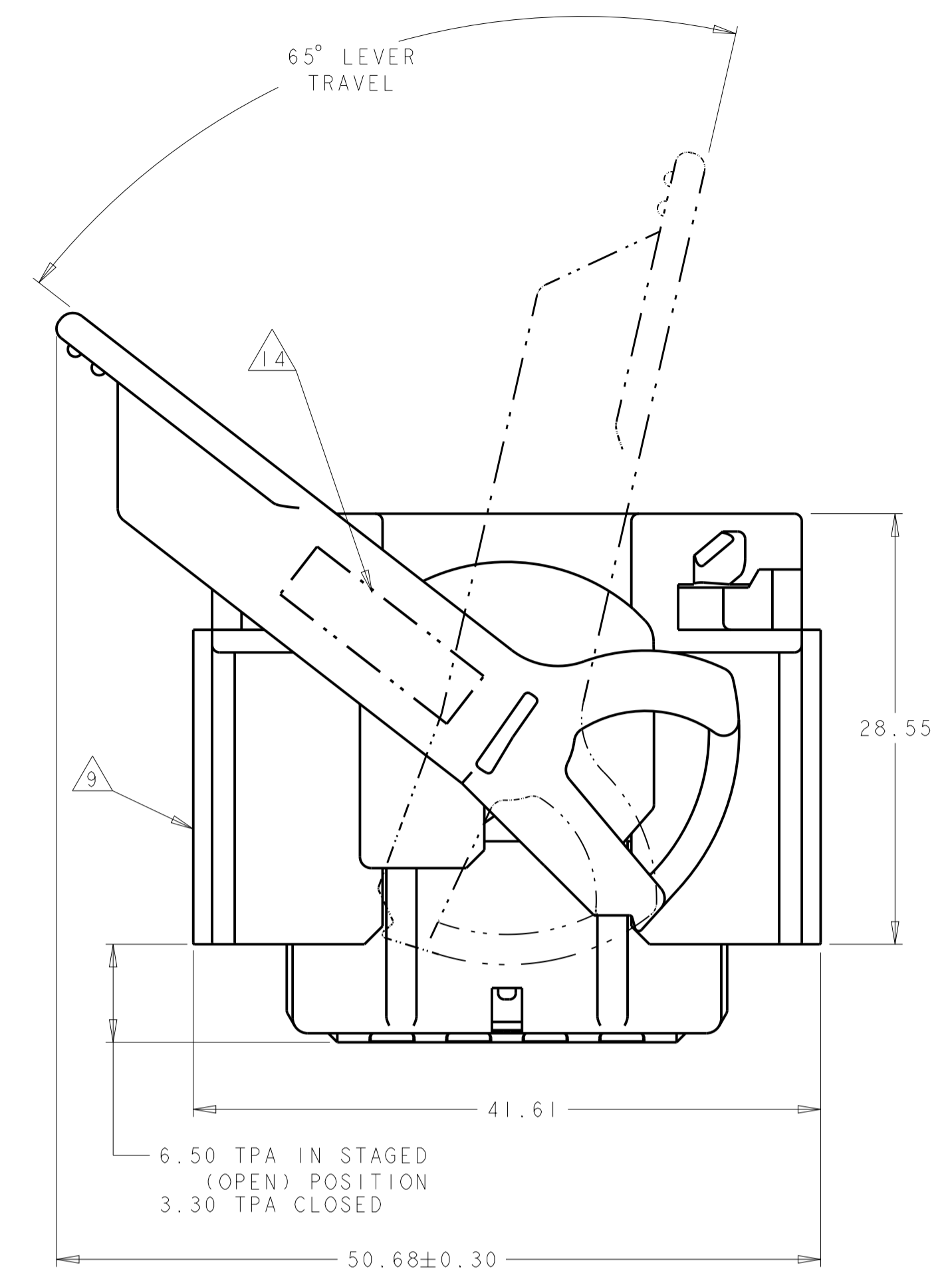

DETAIL B  
SCALE 6:1

SECTION A-A

- 1. MATERIAL: PLUG HOUSING - NYLON 6/6, 35% GLASS-FILLED, YELLOW  
 TPA - NYLON 6/6, 35% GLASS-FILLED, BLACK  
 PERIPHERAL SEAL - SILICONE, LIGHT BLUE  
 MAT SEAL - SILICONE, LIGHT BLUE  
 LEVER - NYLON 6/6, 35% GLASS-FILLED, GRAY  
 SEAL COVER - NYLON 6/6, 35% GLASS-FILLED, BLACK
- 2. APPLICABLE HEADER INTERFACE SPECIFICATION - SEE LAST 2 SHEETS.
- 3. WIRE DRESS, PART NUMBER 776793-2, TO BE PURCHASED SEPARATELY.
- 4. KEY "D" PART FOR PROTOTYPE USE ONLY.
- 5. INSTRUCTION SHEET PER TE SPECIFICATION 408-10334.
- 6. THIS PRODUCT HAS BEEN VALIDATED FOR USE WITH THE FOLLOWING TERMINAL PART NUMBERS AND WIRE SIZES:  
 TE, GENERATION Y, (SILVER PLATED) TERMINAL P/N 2138699-1,  
 GM P/N tbd  
 REF. TERMINAL APPLICATION SPECIFICATION 114-13183  
 WIRE RANGE 0.35 - 0.5mm<sup>2</sup>  
 WIRE INSULATION RANGE: 1.5 to 1.7mm (OUTER DIAMETER)  
 ALSO, WIRE SIZE: 0.75mm<sup>2</sup> IN 2 CIRCUITS MAXIMUM WITH WIRE INSULATION OUTER DIAMETER 1.70 to 1.90mm. USE TE TERMINAL P/N 2138699-2,  
 GM P/N tbd  
 ALSO, GM APPROVED, GMWI5626, ISO WIRE, 0.35mm<sup>2</sup> WIRE SIZE, 1.2mm to 1.4mm WIRE INSULATION OUTER DIAMETER.
- THE 2138699-1, -2 TE CONNECTIVITY TERMINALS ARE GM APPROVED PER GM CONNECTOR GROUP CONNECTOR CHANGE NOTIFICATION BULLETIN #7, TE TERMINALS FOR SDM CONNECTOR, DATED MARCH 26, 2013.
- 7. KEY CONFIGURATION "E" IS FOR GM SERVICE ONLY.
- 8. NOTE REMOVED
- 9. TE PART NUMBER AND JULIAN DATE CODE (YY-DDD-HH-MM) ON THIS SIDE. OPTIONAL MANUAL ASSEMBLY CHARACTER AFTER DATE CODE.
- 10. FOR BLOCKED CIRCUITS FOR SERVICE, PROTOTYPE, AND PRODUCTION APPLICATIONS, USE ONLY TYCO ELECTRONICS INDIVIDUAL SEAL PLUG P/N 1456538-1.
- 11. FOR BLOCKED CIRCUITS REQUIRED IN PRODUCTION APPLICATIONS, REFER TO EXISTING CIRCUIT CONFIGURATIONS (SEE SHEET 3).
- 12. CONNECTOR MEETS GMW3191, CLASS 1, ENVIRONMENTAL, ELECTRICAL, MECHANICAL, AND SEALING CLASS (2) "SEALING" TEST PER GM APPROVED/SIGNED TEST PLANS.
- 13. FOR SILVER PLATED TERMINALS, ELECTRICAL PERFORMANCE IS NOT AFFECTED BY DISCOLORATION OR TARNISH ON SURFACE.
- 14. ALTERNATE MARKING FOR MANUAL ASSEMBLY. MARK TE PART NUMBER, JULIAN DATE, AND KEY ON LEVER APPROXIMATELY AS SHOWN. (YYDD K) Y=YEAR, D=DAY, K=KEY

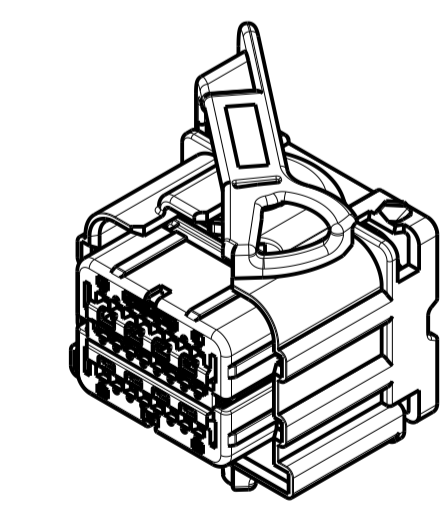

SCALE 1:1

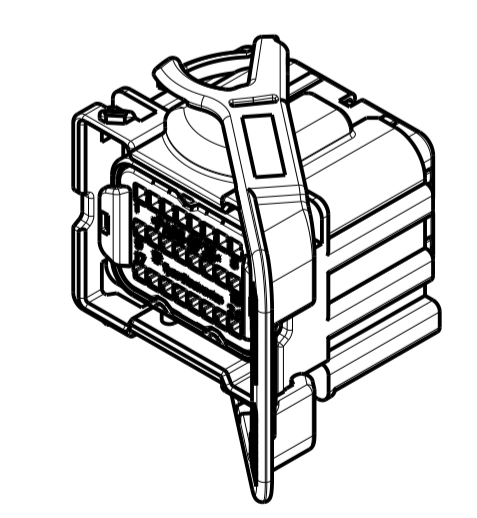

SCALE 1:1

SEE SHEET 3 FOR KEYING CONFIGURATIONS, AND CIRCUIT CONFIGURATIONS

SEE SHEET 2  
PART NUMBER

THIS DRAWING IS A CONTROLLED DOCUMENT.		DWN DL DRUMMOND 14JUN2010		
DIMENSIONS: mm		CHK GENE MILLER 14JUN2010		
TOLERANCES UNLESS OTHERWISE SPECIFIED:		APVD GENE MILLER 14JUN2010	NAME PLUG ASSEMBLY, SEALED 24 POSITION, SDM LEFT HAND LEVER (NO SHUNTS)	
0 PLC	±	PRODUCT SPEC	SIZE CAGE CODE DRAWING NO RESTRICTED TO	
1 PLC	±0.3	APPLICATION SPEC	A100779C=2098923	
2 PLC	±0.2	WEIGHT	SCALE 3:1 SHEET 1 OF 5 REV B6	
3 PLC	±	CUSTOMER DRAWING		
4 PLC	±			
ANGLES	±			
FINISH				

THIS DRAWING IS UNPUBLISHED. RELEASED FOR PUBLICATION  
 © COPYRIGHT 2019 BY TE CONNECTIVITY ALL RIGHTS RESERVED.

REVISIONS				
P.	LTN	DESCRIPTION	DATE	OWN APVD
-	-	SEE SHEET 1	-	-

A2LL/A2SL		C30	C	2-2098923-5
A2LL/A2SL		C29	C	2-2098923-4
A2XX		C25	A	2-2098923-3
ASTRA, BUICK, MY2013	13589163	C22	A	2-2098923-2
ASTRA, OPEL, MY2013	13589162	C21	A	2-2098923-1
GSV 4NB/PM7 AND ONIX	13584044	C6	A	2-2098923-0
COMMODORE	13589164	C19	A	1-2098923-8
ALPHA PED PRO	13580628	C18	A	1-2098923-7
ASTRA, BUICK, MY2010	13579305	C14	A	1-2098923-4
ASTRA, BUICK, MY2010	13579304	C13	A	1-2098923-3
GMX350, VOLT, MY2011	13579303	C12	A	1-2098923-2
INSIGNIA, MY2010	13579302	C11	A	1-2098923-1
INSIGNIA, MY2010	13579301	C10	A	1-2098923-0
GMX511, MY2010	13579300	C5	A	2098923-9
SIGMA, MY2010	13579299	C4	A	2098923-8
GMT172/177, MY2010	13579298	C3	A	2098923-7
GM SERVICE USE	13579297	C1	E  GM SERVICE ONLY UNIVERSAL	2098923-6
INITIAL-EPSILON 11	13579296	C2	A	2098923-5
INITIAL-EPSILON 11	13579294	C1	C	2098923-3
INITIAL-EPSILON 11	13580322	C1	A	2098923-1
VEHICLE PLATFORM/ MODEL YEAR	GM PART NO.	AVAILABLE CIRCUIT CONFIGURATION (SEE SHEET 3)	KEYING CONFIGURATION (SEE SHEET 3)	PART NUMBER

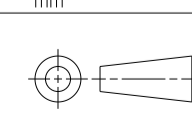
THIS DRAWING IS A CONTROLLED DOCUMENT.		OWN DL DRUMMOND 14JUN2010	
DIMENSIONS: mm		CHK GENE MILLER 14JUN2010	
		APVD GENE MILLER 14JUN2010	NAME PLUG ASSEMBLY, SEALED 24 POSITION, SDM LEFT HAND LEVER (NO SHUNTS)
TOLERANCES UNLESS OTHERWISE SPECIFIED:		PRODUCT SPEC	SIZE CAGE CODE DRAWING NO
0 PLC ±		APPLICATION SPEC	A100779C=2098923
1 PLC ±0.3		RESTRICTED TO	SCALE 1:1 SHEET 2 OF 5 REV B6
2 PLC ±0.2			
3 PLC ±			
4 PLC ±			
ANGLES ±°			
MATERIAL		WEIGHT	CUSTOMER DRAWING

REVISIONS				
P.	LTN	DESCRIPTION	DATE	APP'D
-	-	SEE SHEET 1	-	-

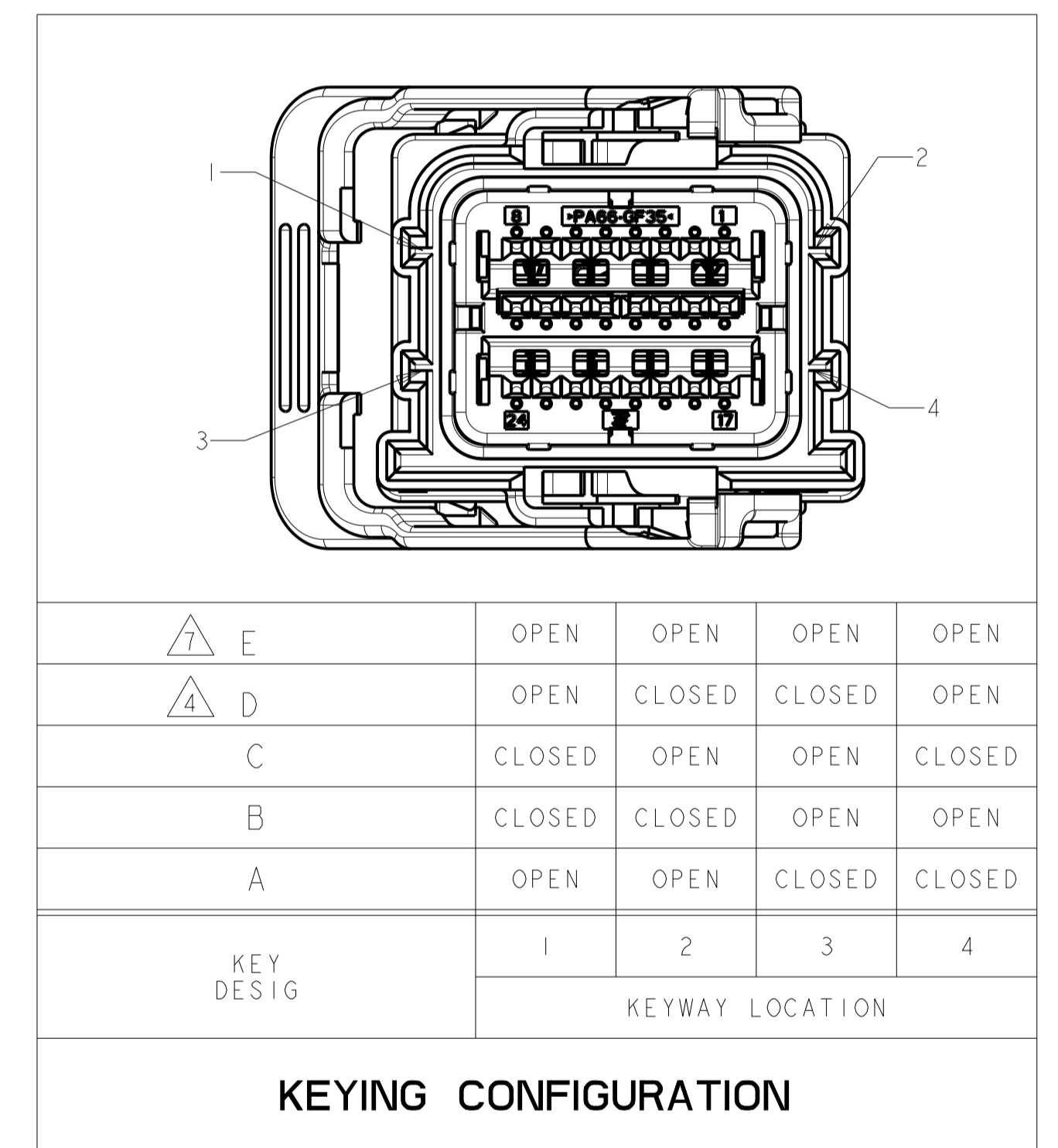
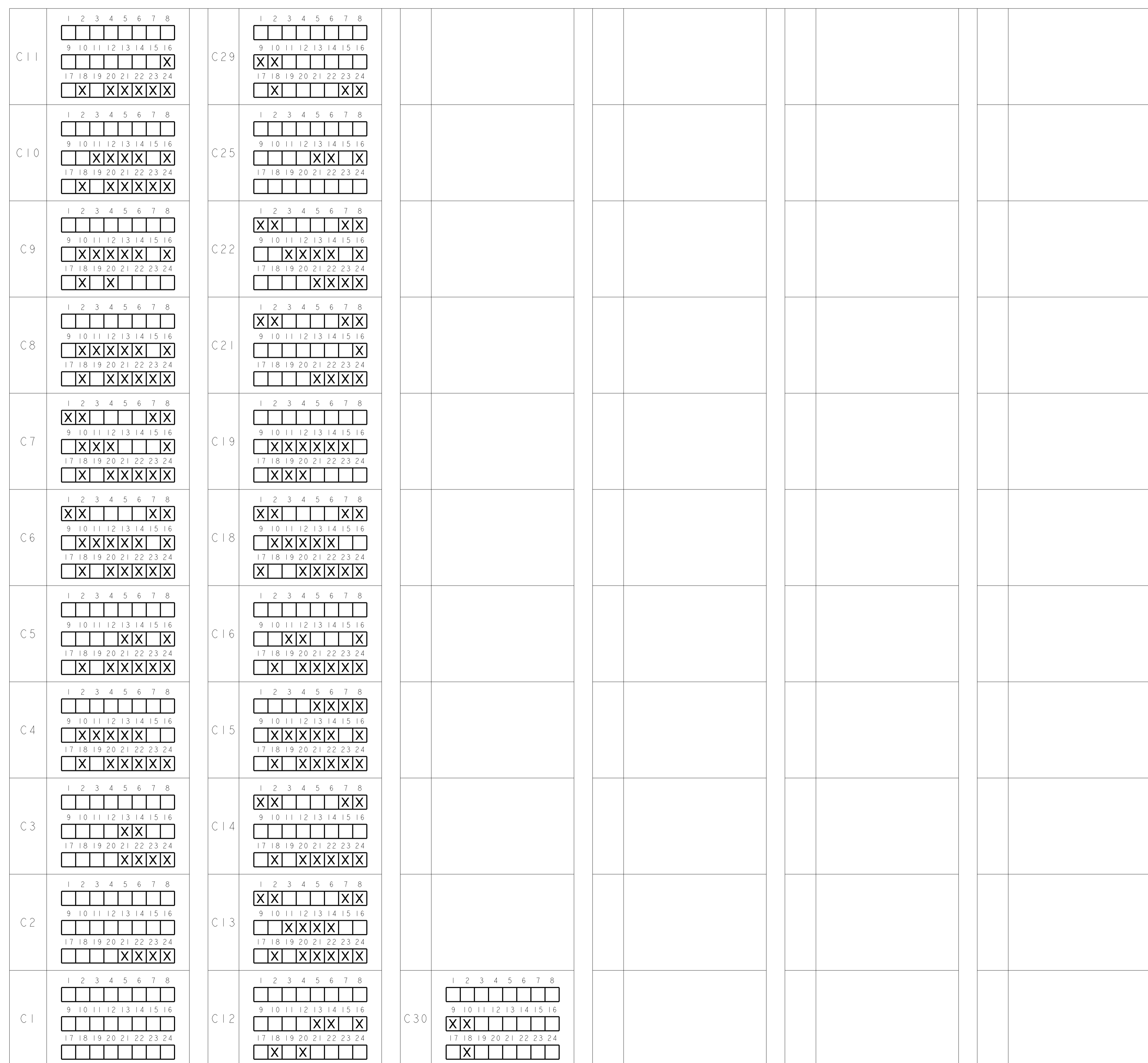

THIS DRAWING IS A CONTROLLED DOCUMENT.

OWN: DL DRUMMOND 14JUN2010  
 CHK: GENE MILLER 14JUN2010  
 APYB: GENE MILLER 14JUN2010

**TE Connectivity**

NAME: PLUG ASSEMBLY, SEALED 24 POSITION, SDM LEFT HAND LEVER (NO SHUNTS)

SIZE: A 100779 C=2098923

SCALE: 1:1 SHEET 3 OF 5 REV: B6

MATERIAL: - FINISH: - WEIGHT: - CUSTOMER DRAWING

TOLERANCES UNLESS OTHERWISE SPECIFIED:  
 0 PLC ±  
 1 PLC ±0.3  
 2 PLC ±0.2  
 3 PLC ±  
 4 PLC ±  
 ANGLES ±2°



# APPLICABLE HEADER INTERFACE SPECIFICATION

REVISIONS				
P.	LTN	DESCRIPTION	DATE	OWN APVD
-	-	SEE SHEET 1	-	-

## RECOMMENDED PIN TIP GEOMETRY 0.63 X 0.62

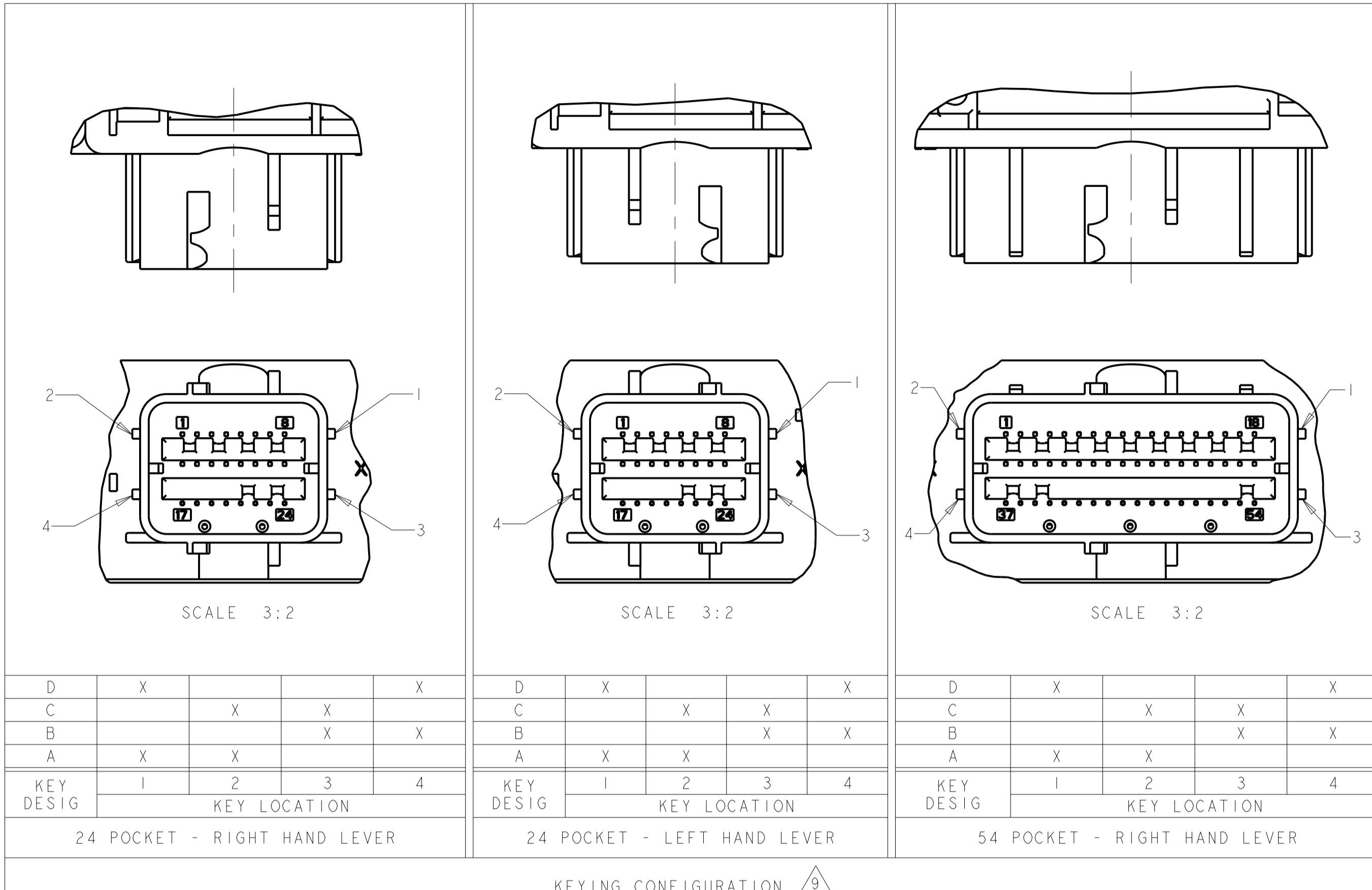
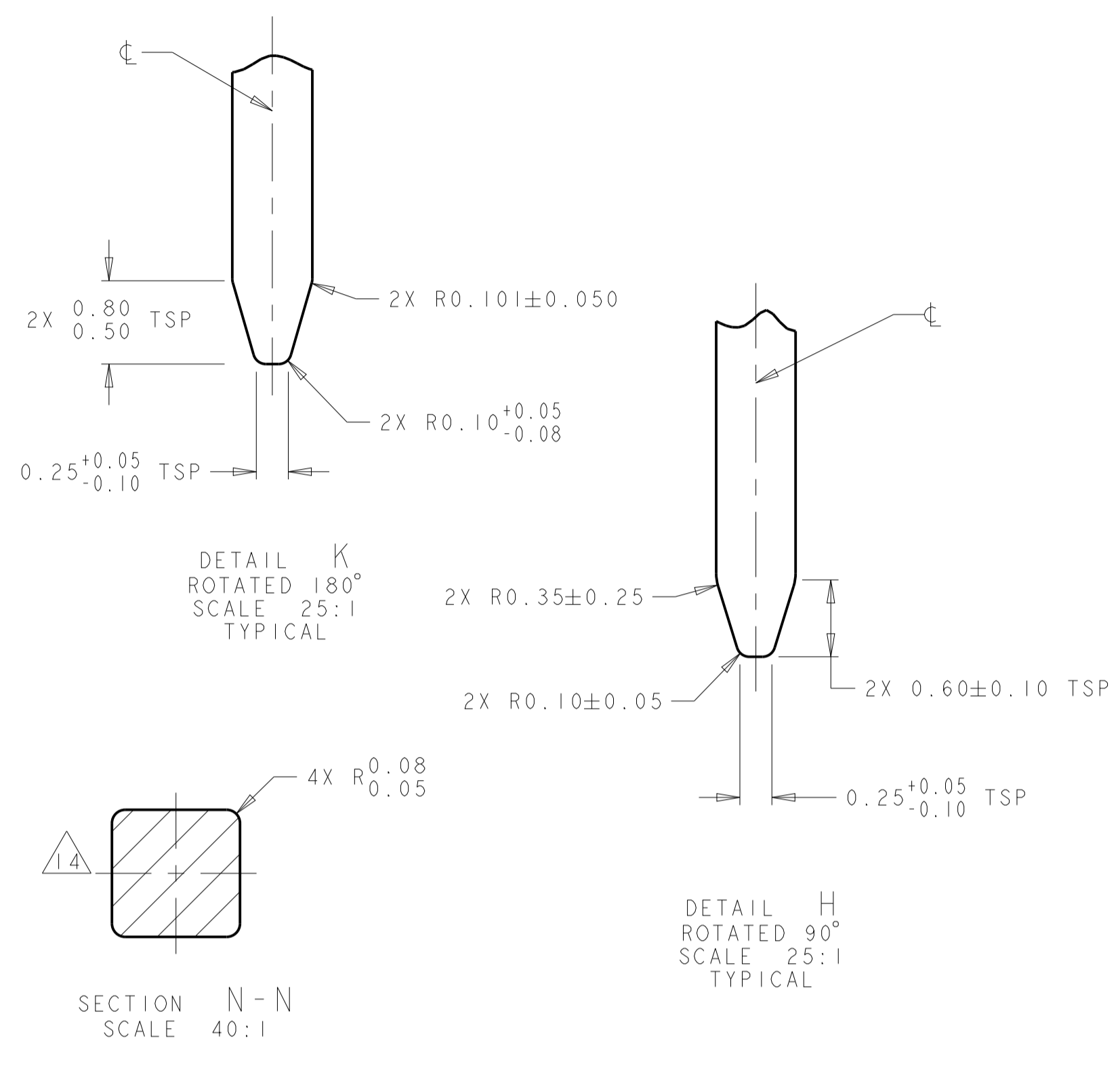

- NOTES: UNLESS OTHERWISE SPECIFIED
- 1 THIS AREA, ALL AROUND, IS A SEALING SURFACE. NO WITNESS LINES OR DAMAGE PERMITTED.
  - 2 SAME GEAR AND PRE-LOCK DIMENSIONS APPLY IN RIGHT HAND VERSUS LEFT HAND ORIENTATIONS. THIS GEOMETRY IS SIMPLY A MIRROR IMAGE.
  - 3 VENT HOLES SIZE AND LOCATION OPTIONAL.
  4. GENERAL TOLERANCE (UNLESS OTHERWISE SPECIFIED)
    - ± 0.2 - ALL ONE PLACE DIMENSIONS
    - ± 0.10 - ALL TWO PLACE DIMENSIONS
    - ± 1° - ALL ANGULAR PLACE DIMENSIONS
  5. DRAFT ANGLE PERMISSIBLE WITHIN PRINT TOLERANCES.
  6. HOUSING AND PIN PLATING MATERIALS SELECTION BASED ON END APPLICATION AND SOLDERING PROCESS. REFERENCE HOUSING MATERIAL POLYESTER (PBT)-30% GLASS AND PHOSPHOR BRONZE, C511 PIN TESTED TO: USCAR2, REV4, CLASS 1, 85°C MAX AMBIENT AND GM W3191, CLASS 1.
  - 7 ALL UNMARKED RADII TO BE 0.5 MAX UNLESS OTHERWISE SPECIFIED.
  - 8 TERMINAL POSITION IDENTIFICATION.
  - 9 MATES WITH TE CONNECTIVITY (TE) PLUG ASSEMBLIES:
    - 24 WAY - LEFT HAND LEVER TE P/N x-2098923-x
    - 24 WAY - RIGHT HAND LEVER TE P/N x-2098924-x
    - 54 WAY - RIGHT HAND LEVER TE P/N x-2098922-x
  - 10 THIS AREA TO REMAIN CLEAR FOR THE HARNESS ASSEMBLY.
  11. PART TO BE FREE OF CONTAMINATION THAT MAY AFFECT FUNCTION OF PART.
  - 12 DIMENSION TO BE MEASURED 2.5 - 6.5 FROM TOP OF CONNECTOR SHROUD.
  13. ALL KEYS SHOWN, SEE TABLE "KEYING CONFIGURATION" REQUIREMENT AND KEY OPTIONS.
  - 14 MATING END OF PIN TO BE FREE OF SHARP EDGES AND BURRS.
  - 15 FEMALE TERMINAL MATING AREA FOR SILVER PLATED APPLICATIONS, REF USCAR2, REV4, CLASS 1, 85°C MAX AMBIENT. 2 TO 4µm THICK SILVER OVER 2.0µm MIN THICK NICKEL UNDERPLATE ALL OVER.

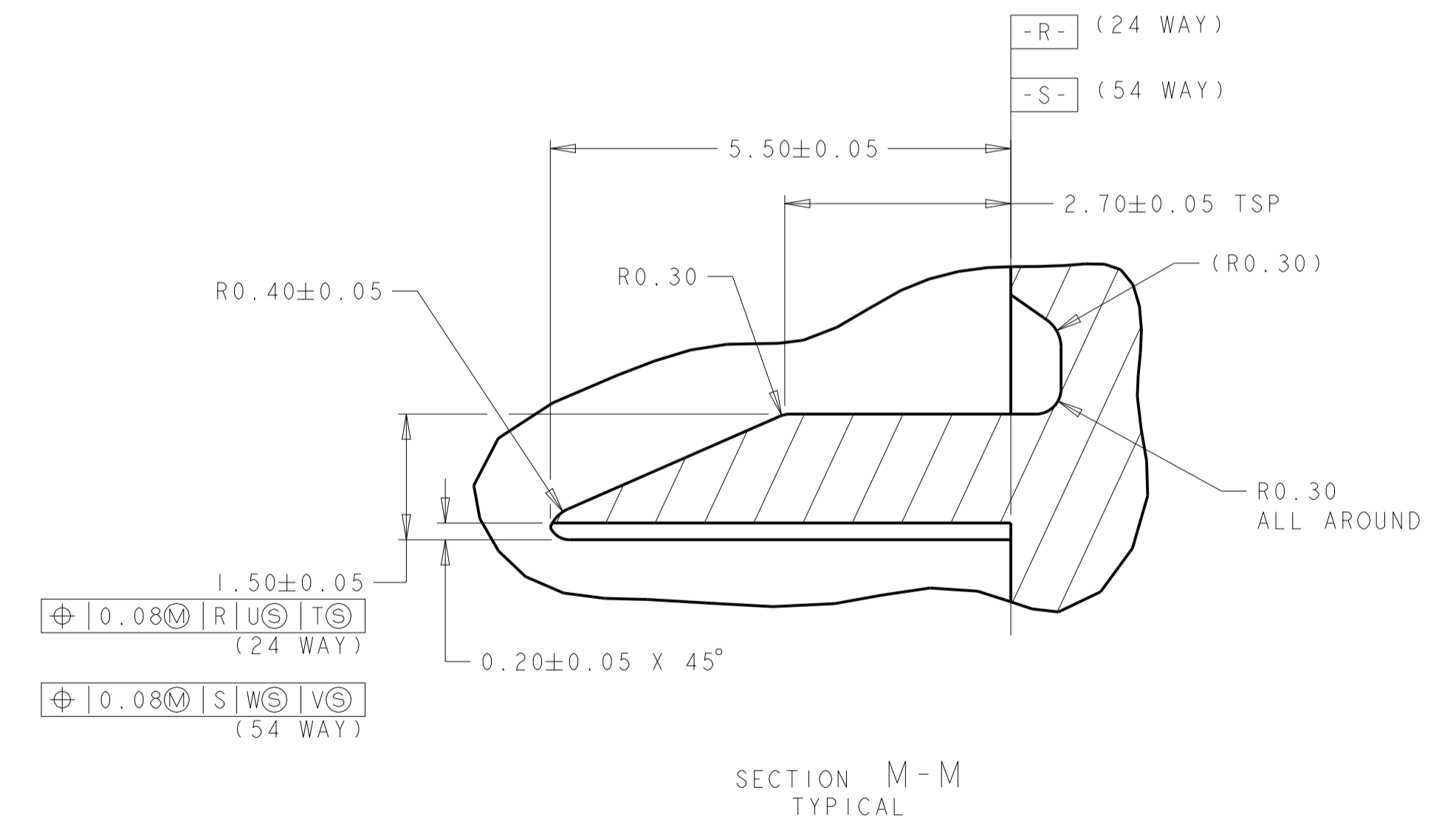
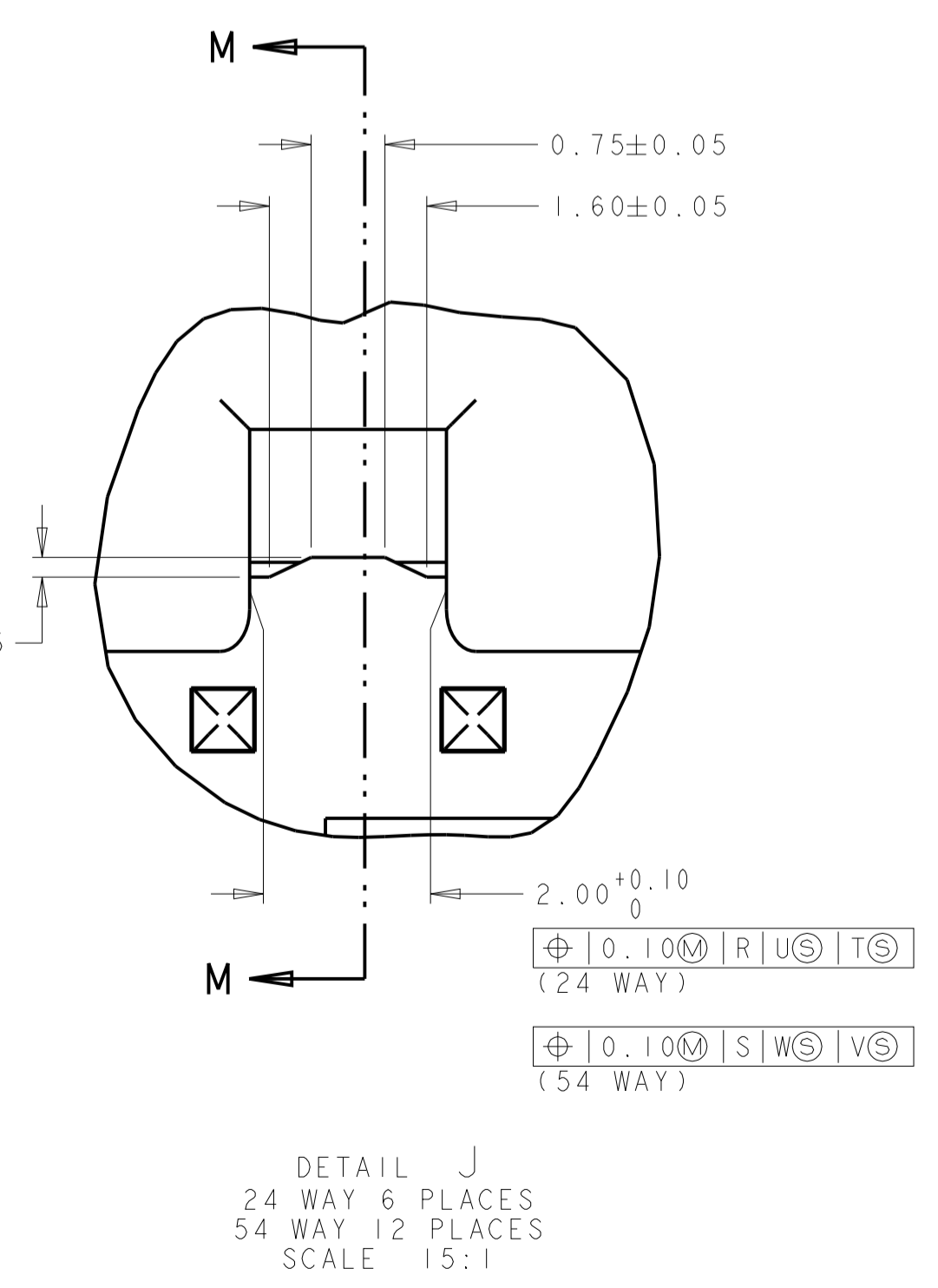
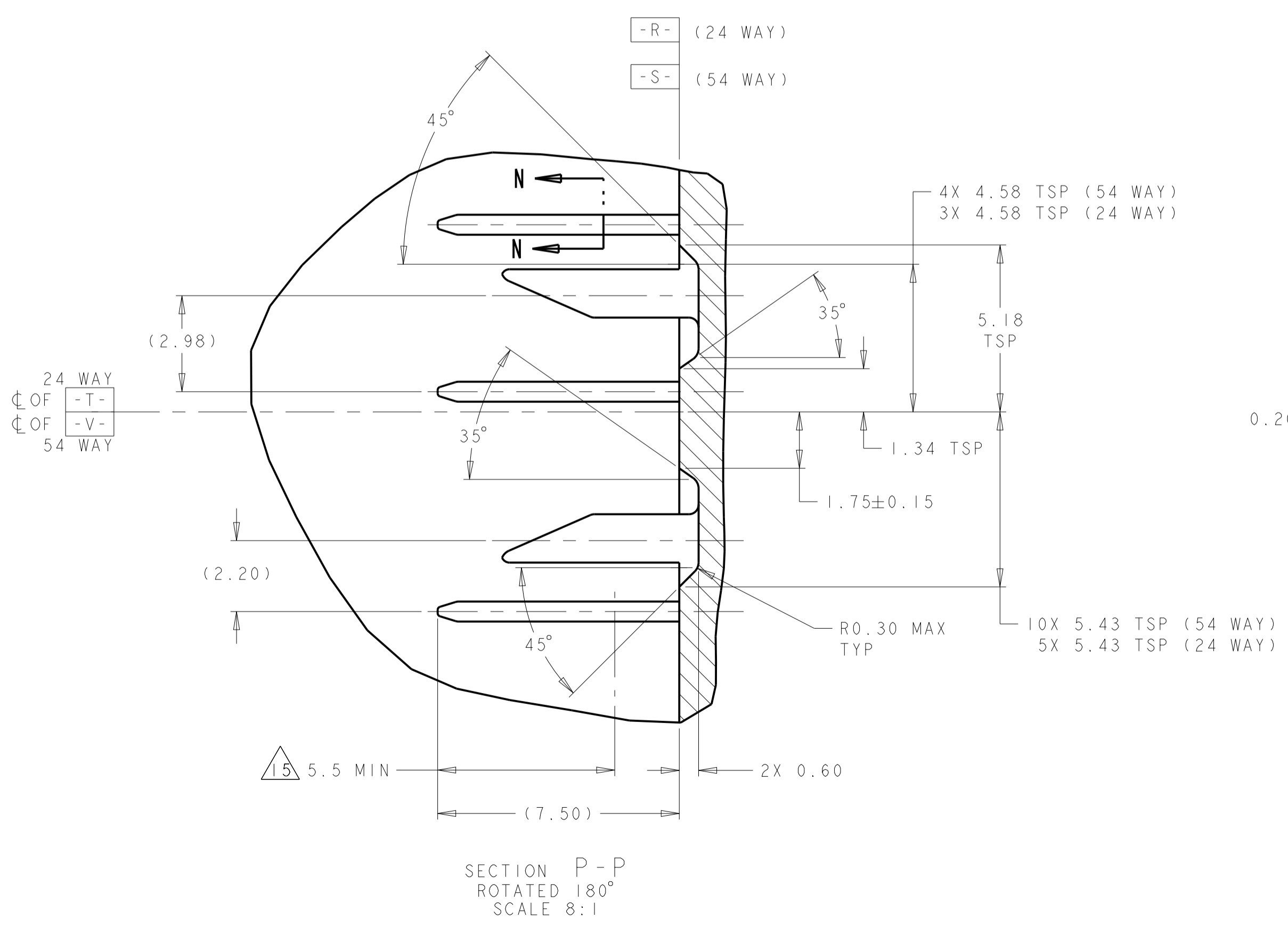

THIS DRAWING IS A CONTROLLED DOCUMENT.		OWN DL DRUMMOND 14JUN2010	TE Connectivity
DIMENSIONS: mm		CHK GENE MILLER 14JUN2010	
TOLERANCES UNLESS OTHERWISE SPECIFIED:		APVD GENE MILLER 14JUN2010	NAME PLUG ASSEMBLY, SEALED 24 POSITION, SDM LEFT HAND LEVER (NO SHUNTS)
0 PLC ±		PRODUCT SPEC	SIZE CAGE CODE DRAWING NO RESTRICTED TO
1 PLC ±0.3		APPLICATION SPEC	A100779C=2098923
2 PLC ±0.2		WEIGHT	SCALE 3:1 SHEET 5 OF 5 REV B6
3 PLC ±		CUSTOMER DRAWING	
4 PLC ±			
ANGLES ±°			
FINISH			