

REVISIONS

P	LTR	DESCRIPTION	DATE	DWN	APVD
	B1	REVISED (ECR-21-107954)	21.JUL.21	SJ	YJ

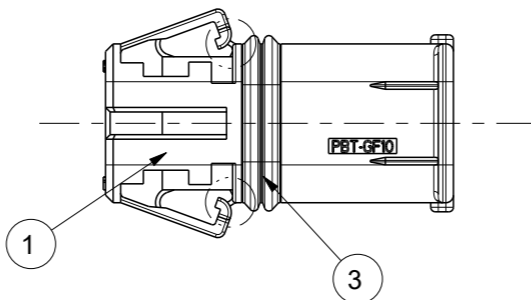
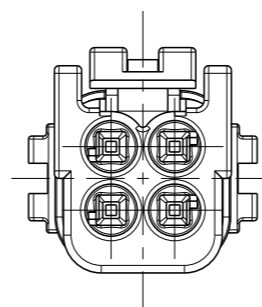
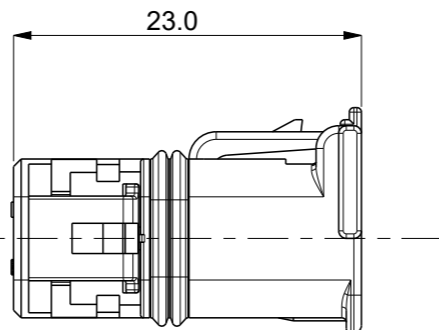
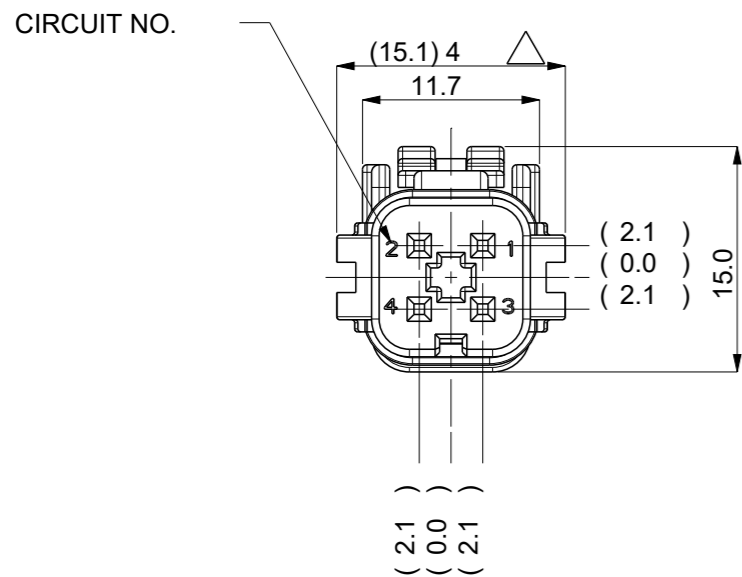
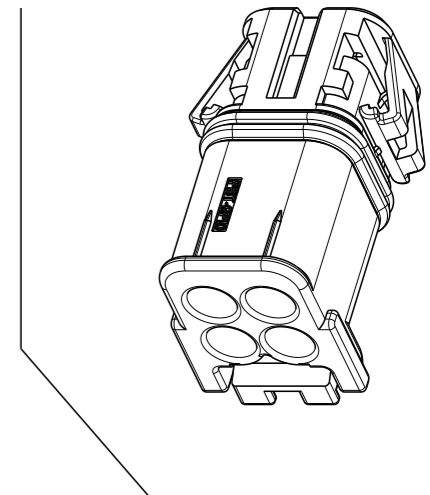
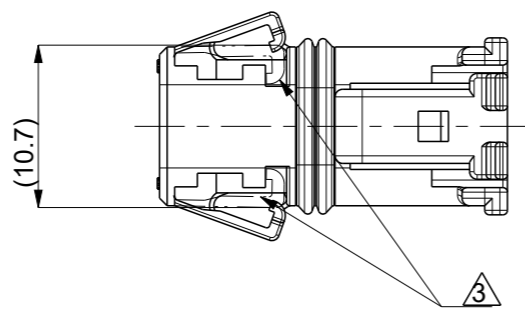

NOTE

- 1. GENERAL TOLERANCE : $\pm 0.3, \pm 3^\circ$
- 2. THE MATING CONNECTOR : 2109102
- 3. DBL:SECOND LOCK POSITION. BEFORE MATING CONDITION.
- 4. DELIVERY CONDITION : DBL SHOULD BE OPENED.
- 5. APPLICABLE REC : SEE TABLE BELOW

REC	REC P/N	WIRE SIZE	WIRE INSULATION	WIRE SEAL P/N
MQS 025	5-962885-1	0.25-0.5	ϕ 0.9-1.4	967067-2
	5-965906-1	0.5-0.75	ϕ 1.4-1.9	967067-1

NO.	COLOR	MATERIAL	DESCRIPTION	REV.	Q'TY
3	RED ORANGE	SILICONE	INNER SEAL	A	1
2	BLACK	PBT-GF10	PLUG HSG	A	1
1	BLACK	PBT-GF10	PLUG HSG	B	1

B	A	REV
2109100-2		
	1-2109100-2	
		P/N
		DESCRIPTION
		MQS SLD 4P PLUG ASSY
		MQS SLD 4P PLUG ASSY

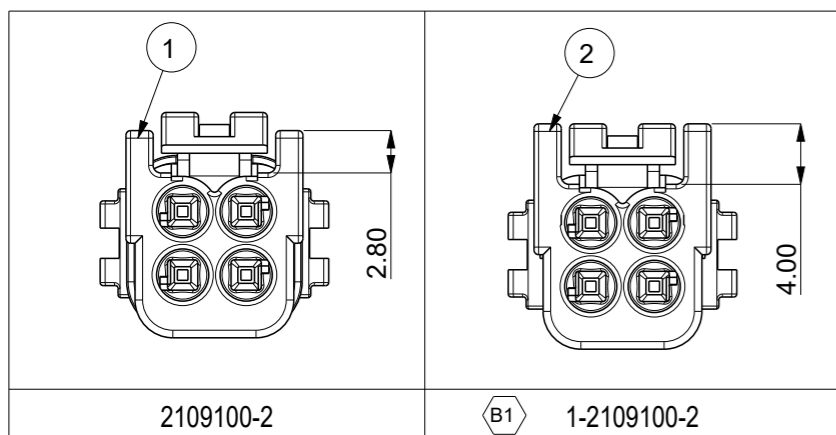

THIS DRAWING IS A CONTROLLED DOCUMENT.

DIMENSIONS: mm

TOLERANCES UNLESS OTHERWISE SPECIFIED:

0 PLC	\pm
1 PLC	\pm
2 PLC	\pm
3 PLC	\pm
4 PLC	\pm
ANGLES	\pm
FINISH	-

MATERIAL: SEE TABLE

THIS DRAWING IS A CONTROLLED DOCUMENT.

DWN: SJ CHOI
CHK: JW JUNG
APVD: HG CHO

PRODUCT SPEC: -
APPLICATION SPEC: -
WEIGHT: -

CUSTOMER DRAWING

TE Connectivity

NAME: MQS SLD 4P PLUG ASSY

SIZE: A3
CAGE CODE: -
DRAWING NO: C-2109100

RESTRICTED TO: -

SCALE: 2:1
SHEET: 1 OF 1
REV: B1