

4

3

2

1

THIS DRAWING IS UNPUBLISHED. RELEASED FOR PUBLICATION ,19 .
 © COPYRIGHT 19 BY AMP INCORPORATED. ALL RIGHTS RESERVED.

LOC	DIST	REVISIONS					
		P	LTR	DESCRIPTION	DATE	DWN	APVD
			C1	REVISED (ECR-20-004925)	2/APR/'20	SY	YJ
			C2	REVISED (ECR-23-179656)	28/JUN/'23	SY	KT
			C3	REVISED (ECR-23-181586)	18/JUL/'23	SY	KT

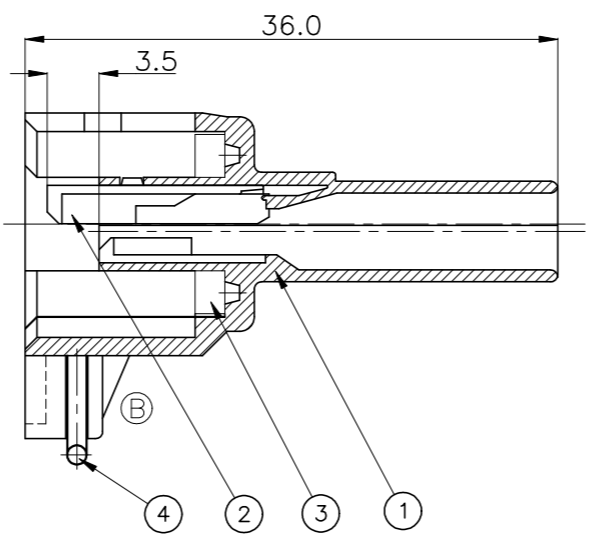
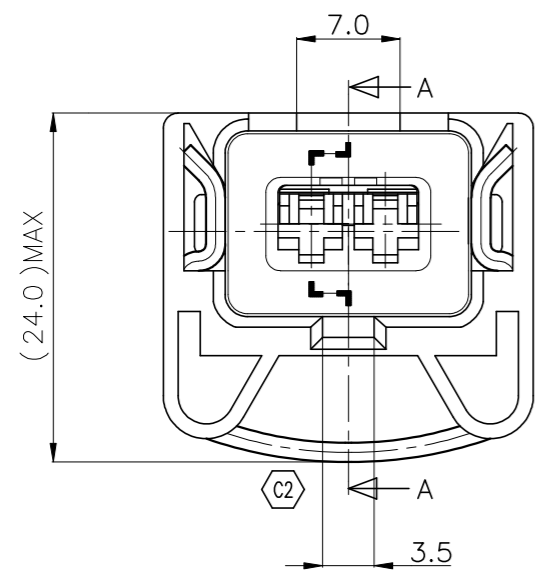

SECTION A-A

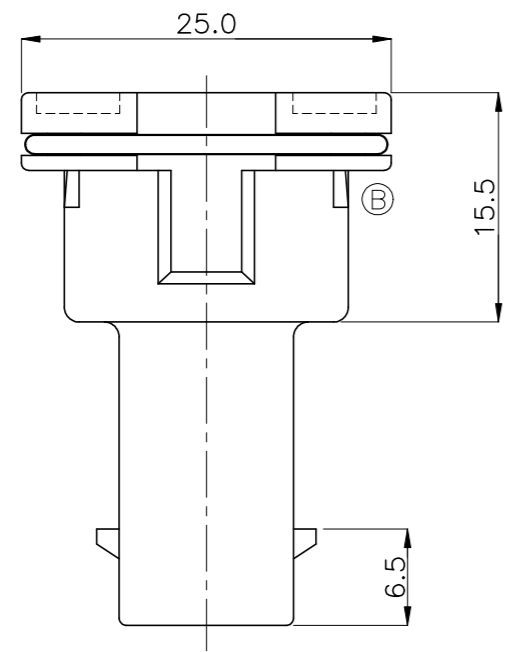

DESCRIPTION	P/NO	1-368354-2	368354-5	368354-4	368354-3	368354-2	368354-1
JPT 2P ASS'Y FOR CLIP		1					
JPT 2P ASS'Y FOR CLIP			1				
JPT 2P ASS'Y FOR CLIP				1			
JPT 2P ASS'Y FOR CLIP					1		
JPT 2P ASS'Y FOR CLIP						1	
JPT 2P ASS'Y FOR CLIP							1

* NOTES *

- 1. APPLICABLE CONTACT P/NO: 927770 / 927766
- 2. APPLICABLE WIRE SEAL P/NO: 828904 / 828905 / 368064

NO	DESCRIPTION	MATERIAL	COLOR	Q'TY				
4	SPRING	SUS 304		1	1	1	1	1
C1 3	SEAL RUBBER	SILICONE	BLUE	1				
3	SEAL RUBBER	SILICONE	ORANGE		1	1	1	1
2	SPACER	PBT	YELLOW	1	1	1	1	1
C3 1	JPT 2P HSG FOR CLIP	PBT 30% GF	DARK GRAY		1			
1	JPT 2P HSG FOR CLIP	PBT 30% GF	BROWN			1		
1	JPT 2P HSG FOR CLIP	PBT 30% GF	GREEN				1	
1	JPT 2P HSG FOR CLIP	PBT 30% GF	BLUE					1
1	JPT 2P HSG FOR CLIP	PBT 30% GF	BLACK	1				1

THIS DRAWING IS A CONTROLLED DOCUMENT FOR AMP INCORPORATED. IT IS SUBJECT TO CHANGE AND THE CONTROLLING ENGINEERING ORGANIZATION SHOULD BE CONTACTED FOR THE LATEST REVISION.		DWN	TE Connectivity		
DIMENSIONS: MM		CHK			
TOLERANCES UNLESS OTHERWISE SPECIFIED: 0<XX<10 ± 0.2 10<XX<30 ± 0.25 30<XX<100 ± 0.3 ANGLES ± 3°		APVD	NAME		
3rd ANGLE PROJECTION		PRODUCT SPEC	JPT 2P ASS'Y FOR CLIP		
MATERIAL		APPLICATION SPEC	SIZE	CAGE CODE	DRAWING NO
FINISH		WEIGHT	A3	00779	© 3 6 8 3 5 4
			SCALE 2/1 SHEET 1 OF 1 REV C3		