

THIS DRAWING IS UNPUBLISHED. RELEASED FOR PUBLICATION
 © COPYRIGHT - By - ALL RIGHTS RESERVED.

LOC	DIST	REVISIONS			
P	LTR	DESCRIPTION	DATE	DWN	APVD
AF	50	N1	ECR-15-005665	10AUG2015	BDA PKS

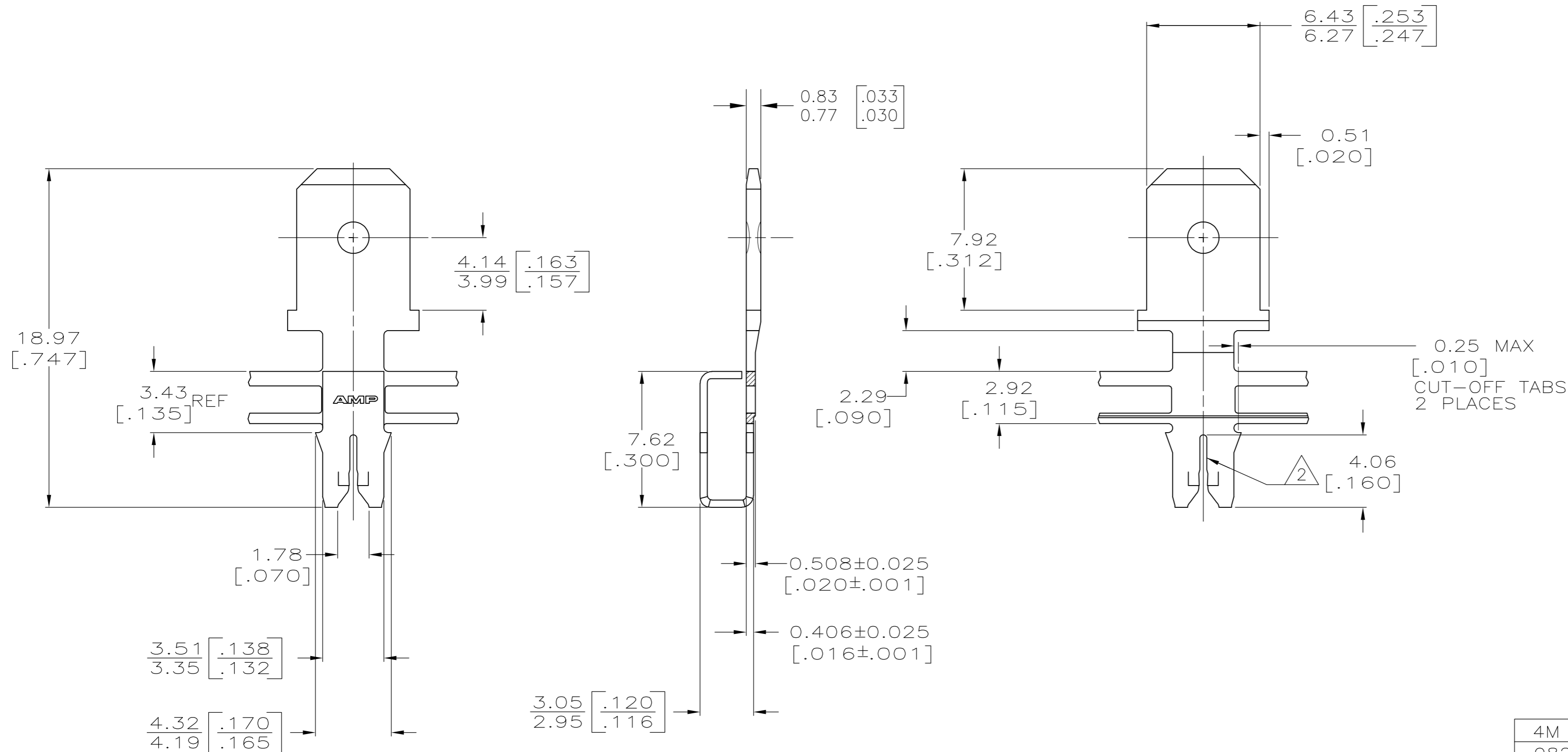

- CONTINUOUS STRIP ON REELS WITH TERMINALS LOCATED ON 8.38 [.330] CENTERS.
- SLOT TERMINATES A SINGLE MAGNET WIRE, COPPER RANGE IS 0.64-0.81mm [#22-#20] AWG. ALUMINUM RANGE IS 0.72-0.91mm [#21-#19] AWG. ALUMINUM WIRE RANGE APPLIES FOR POST-TIN PLATED VERSIONS ONLY.
- AFTER INSERTION INTO PLASTIC HOLDER TAB PORTION MUST BE BENT OVER 45° TO 90° OR POTTED-IN TO PREVENT PULL-OUT WHEN MATING RECEPTACLE IS DISCONNECTED.



MATERIAL	PART NO
4M HARD PRE-MILLED BRASS	62653-3
082 HARD PRE-MILLED BRASS	62653-2
4M HARD PRE-MILLED BRASS	62653-1

THIS DRAWING IS A CONTROLLED DOCUMENT.		DWN MICHAEL S. FEHER 1/3/92		
DIMENSIONS: INCHES		CHK PHILLIP FORTNEY 1/6/92		
TOLERANCES UNLESS OTHERWISE SPECIFIED:		APVD NELSON E. NEFF 1/6/92	NAME TAB, 6.35 [.250] FASTON™ MAG-MATE™	
0 PLC ± -		PRODUCT SPEC 108-2012	SIZE A2	CAGE CODE 00779
1 PLC ± -		APPLICATION SPEC 114-2046	DRAWING NO C=62653	RESTRICTED TO -
2 PLC ± 0.25 [.010]		WEIGHT -	SCALE 5:1	SHEET 1 of 1
3 PLC ± -		CUSTOMER DRAWING	REV N1	
4 PLC ± -				
ANGLES ± -				
FINISH 0.002037 [.000080]				