

REVISIONS				
P	LTN	DESCRIPTION	DATE	APVD
K12		REVISED PER ECO-19-009419	20JUN2019	DS DS
K13		REVISED PER ECO-20-004256	26MAR2020	JM DS
K14		REVISED PER PCN E-20-016603	24NOV2020	PN DS
L		REVISED PER ECN-21-123056	08NOV2021	DK CB

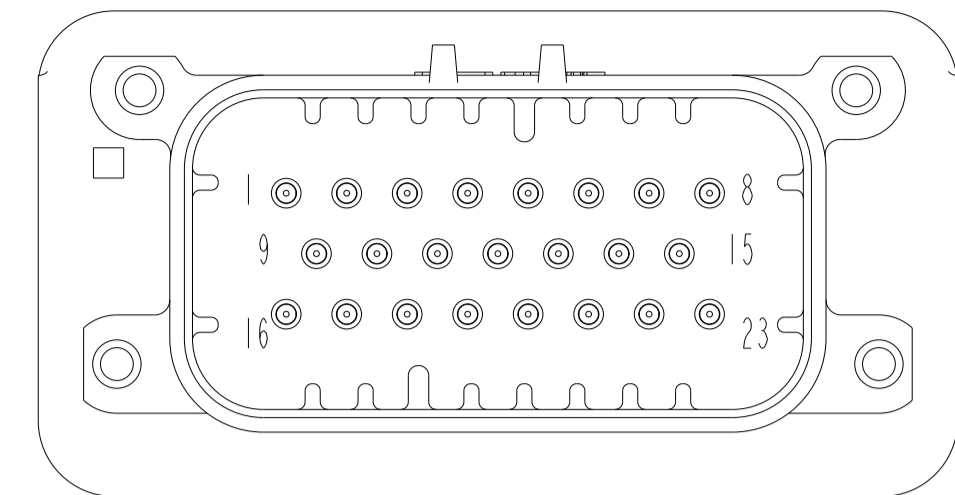

770669-2 & 1-770669-2  
KEY LOCATION  
SCALE 2:1

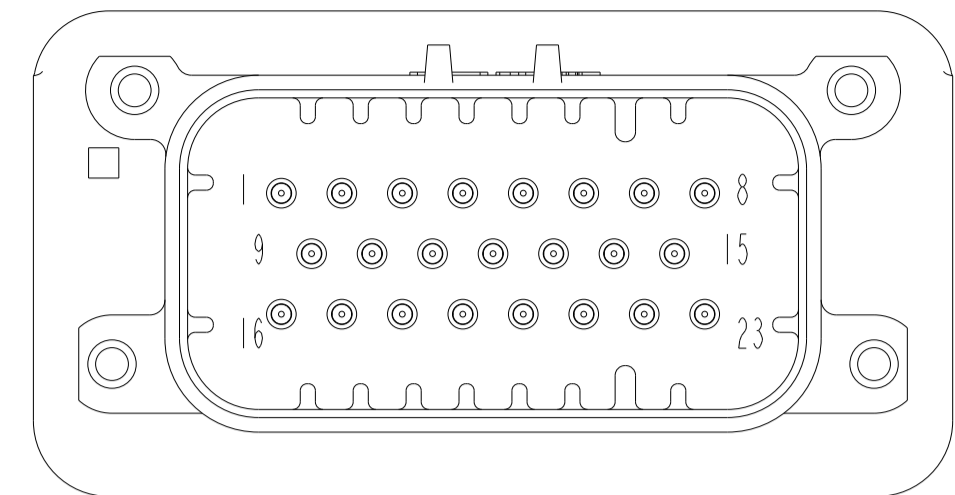

770669-4 & 1-770669-4  
KEY LOCATION  
SCALE 2:1

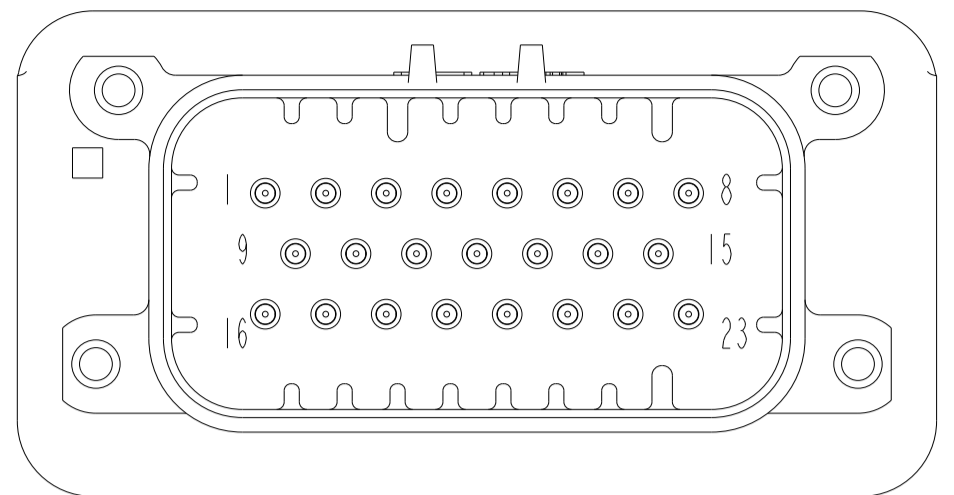

770669-5 & 1-770669-5  
KEY LOCATION  
SCALE 2:1

- 1. SUGGESTED MOUNTING SCREW SIZE IS  $\varnothing 2.50-3.00\text{mm}$  [ $\varnothing 0.099 - 0.118$  INCH] SELF TAPPING THREAD FORMING SCREW, SUCH AS DELTA PT, TO BE DRIVEN AT 0.6-0.8 N-m. THE CUSTOMER SHOULD TEST THE SCREW SIZE AND TYPE IN ORDER TO VERIFY THEIR SELECTION FOR THEIR APPLICATION
- 2. DATE CODE TO BE BRANDED IN THIS LOCATION PER TE SPEC 102-60. USE 5 DIGIT CODE: FIRST 2 DIGITS = YEAR, SECOND 2 DIGITS = WEEK, LAST DIGIT = DAY
- 3. HOUSING COLORS ARE MECHANICALLY KEYPED TO MATE ONLY WITH IDENTICALLY COLORED PLUG ASSEMBLIES
- 4. MATERIALS: HEADER HOUSING - GLASS FILLED PBT  
PINS: TIN OR GOLD PLATED BRASS
- 5. HEADER MATES TO PLUG ASSEMBLY 770680 WHICH USES REELED TERMINALS 770520 OR LOOSE PIECE TERMINALS 770854

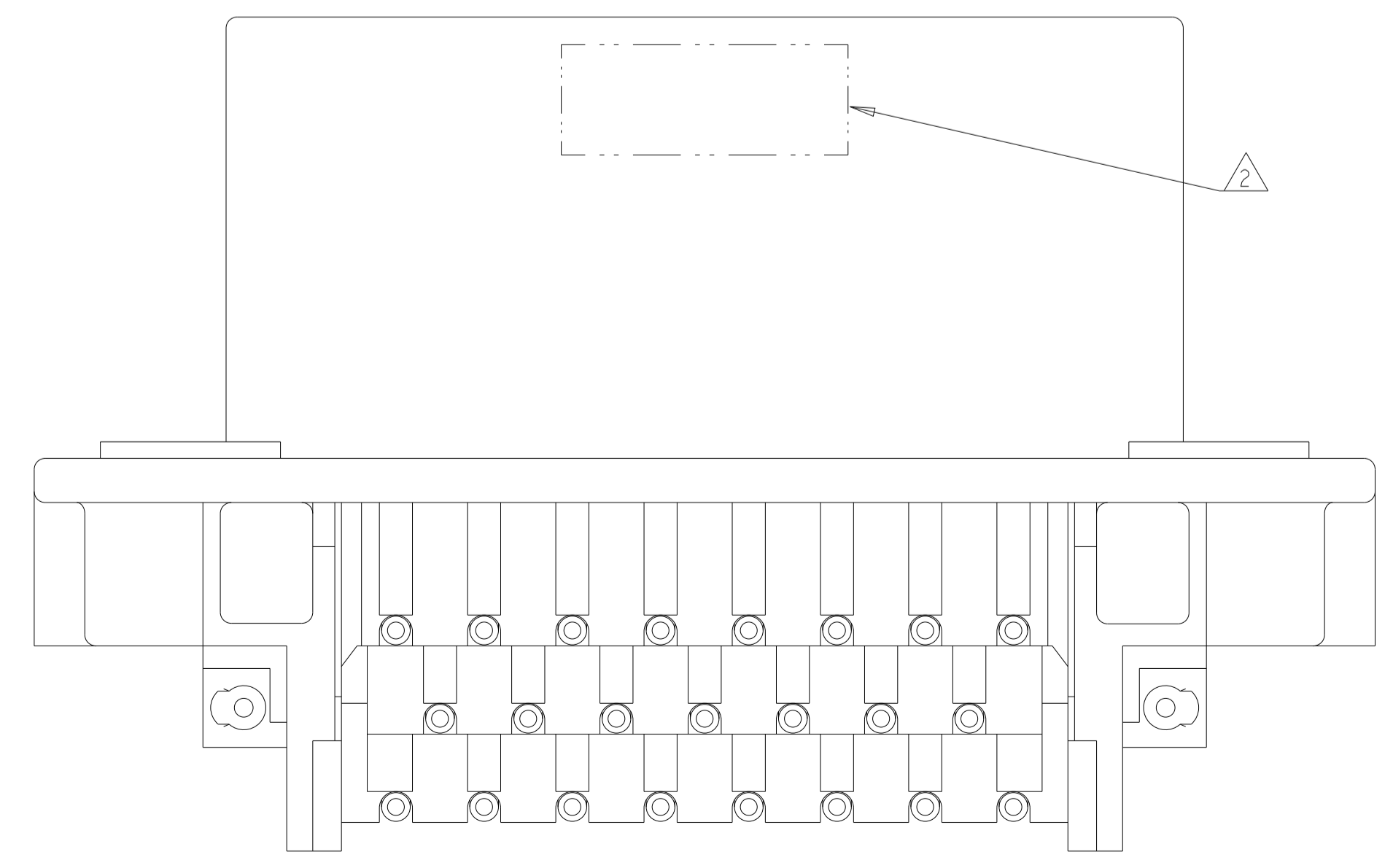
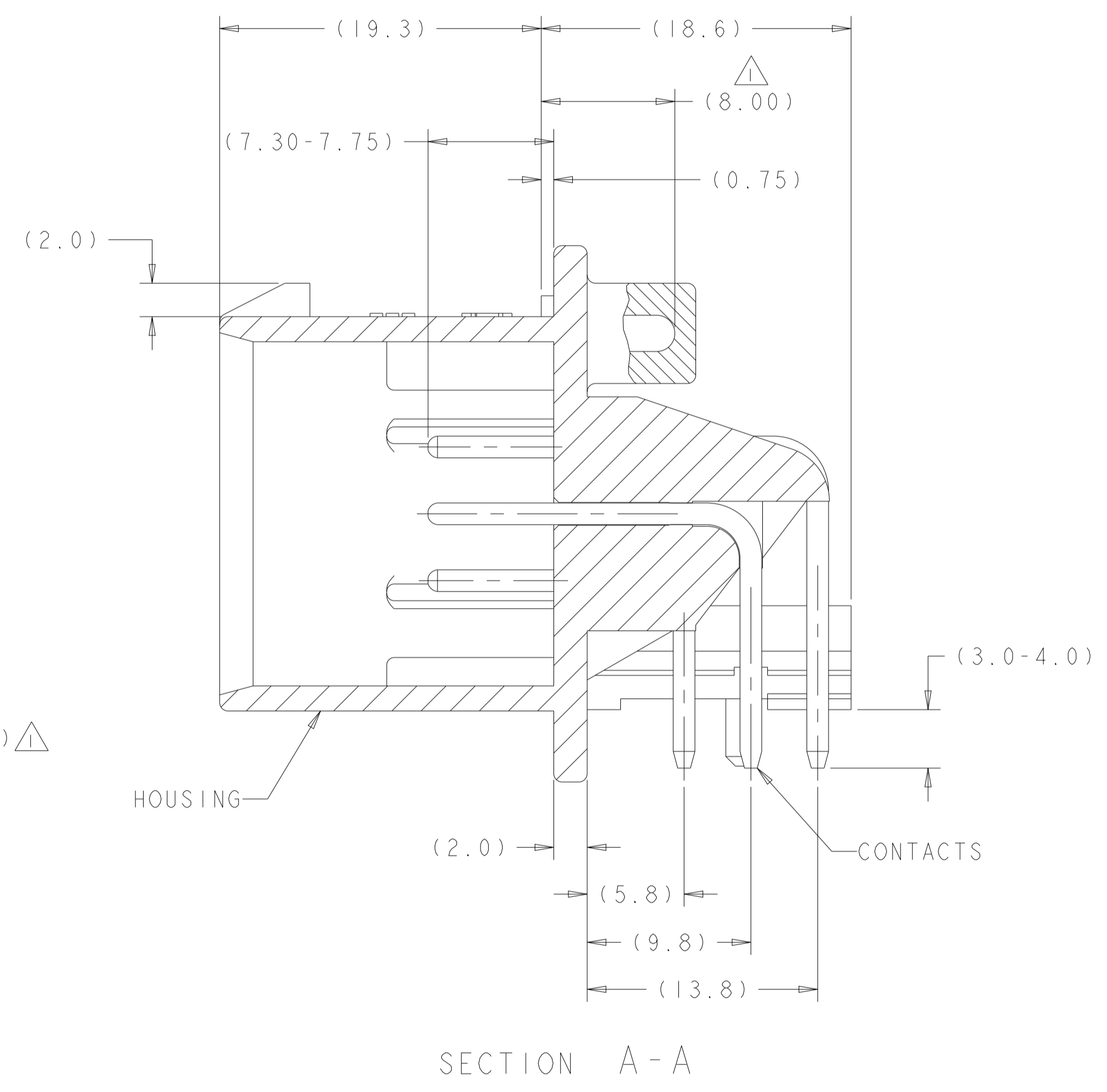
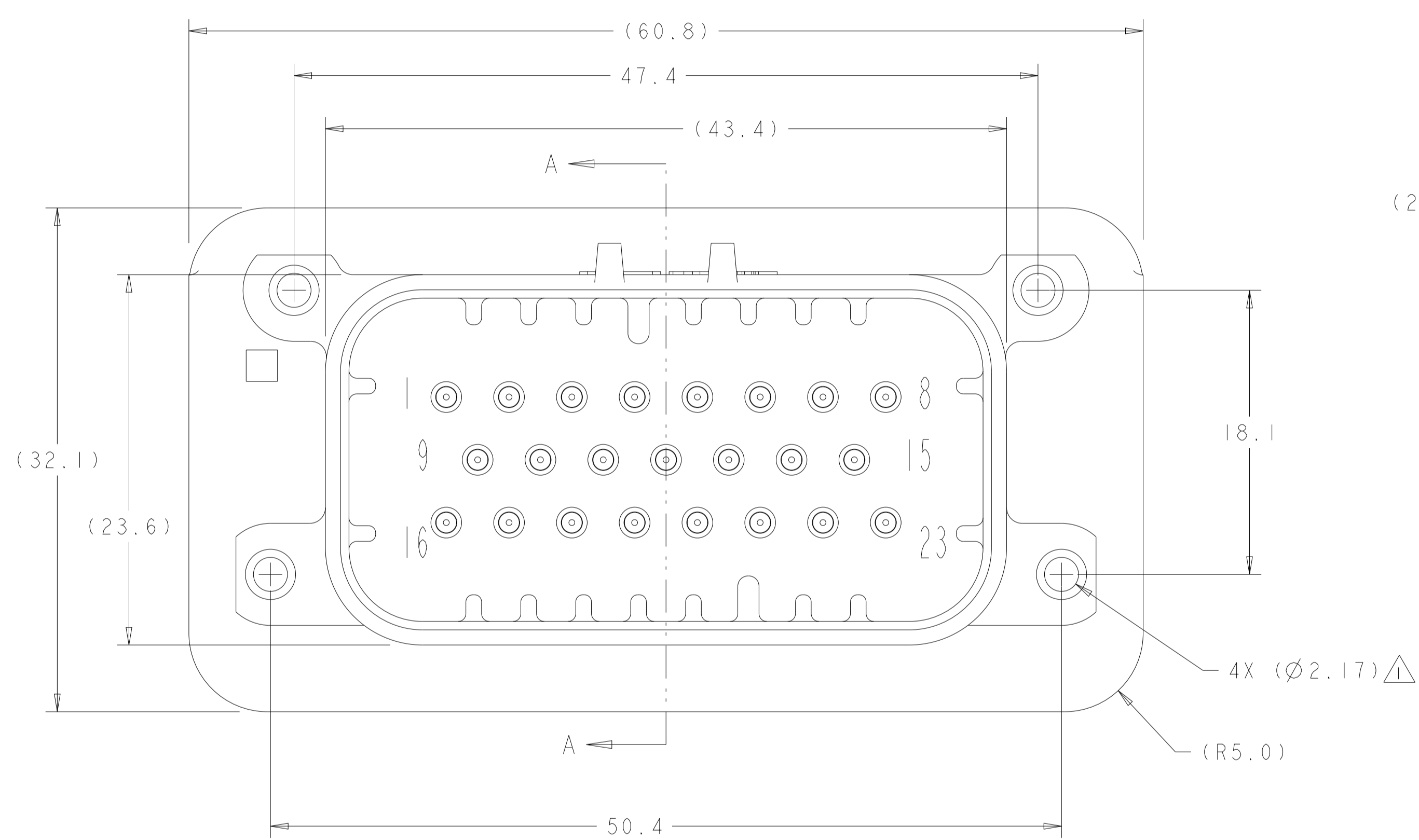

770669-1 & 1-770669-1  
KEY LOCATION AS SHOWN

GOLD	BLUE	1-770669-5
GOLD	GRAY	1-770669-4
GOLD	NATURAL	1-770669-2
GOLD	BLACK	1-770669-1
TIN	BLUE	770669-5
TIN	GRAY	770669-4
TIN	NATURAL	770669-2
TIN	BLACK	770669-1
PLATING	HEADER COLOR/3	PART NUMBER

THIS DRAWING IS A CONTROLLED DOCUMENT.

DIMENSIONS:	TOLERANCES UNLESS OTHERWISE SPECIFIED:	OWN: R. VESTAL 31DEC2002	APVD: D. CROWE 31DEC2002
mm	0 PLC ±0.2	CHK: D. CROWE 31DEC2002	NAME: R. VESTAL
	1 PLC ±0.2	APVD: D. CROWE 31DEC2002	PRODUCT SPEC: 108-1329
	2 PLC ±0.2	APVD: D. CROWE 31DEC2002	APPLICATION SPEC: 114-16016
	3 PLC ±0.2	APVD: D. CROWE 31DEC2002	SIZE: A1
	4 PLC ±0.2	APVD: D. CROWE 31DEC2002	WEIGHT: 28.74g
	ANGLES ±0.1	APVD: D. CROWE 31DEC2002	CUSTOMER DRAWING
	FINISH ±0.1	APVD: D. CROWE 31DEC2002	SCALE: 2:1

TE Connectivity  
HEADER ASSEMBLY, 23 POSITION, RIGHT ANGLE AMPSEAL  
A100779 ©=770669  
SHEET 1 OF 2 REV L

REVISIONS				
P.	LTN.	DESCRIPTION	DATE	APPD.
-	-	SEE SHEET 1	-	-

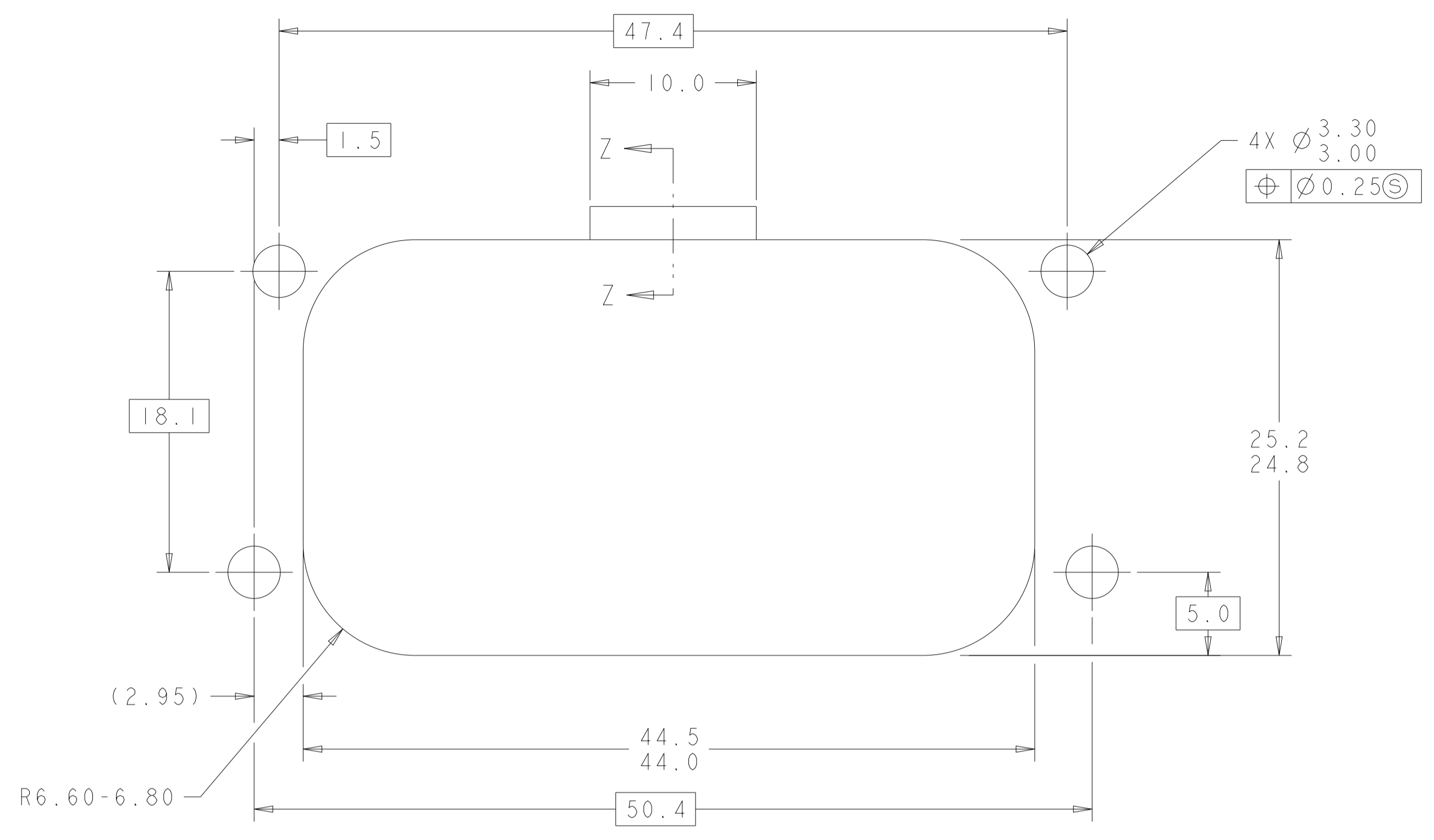

RECOMMENDED MOUNTING HOLE LAYOUT FOR 5.0 MAX THICK PANEL

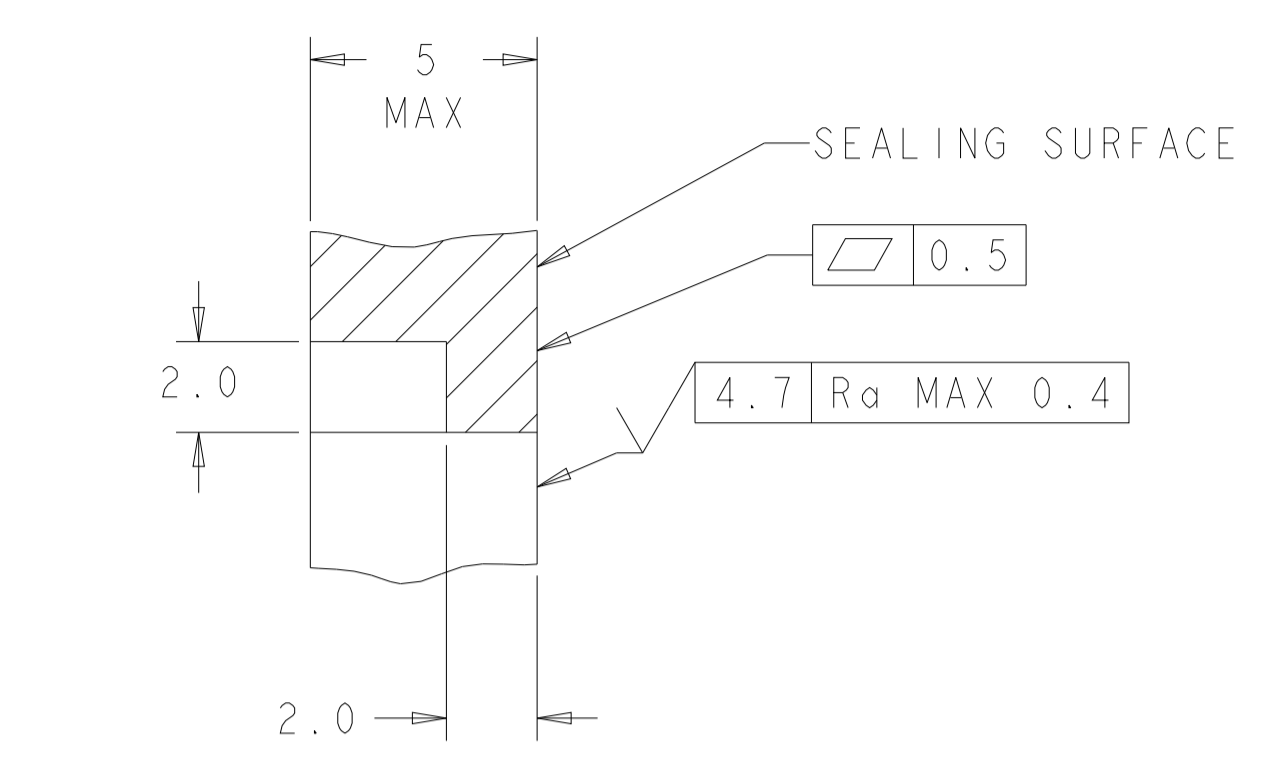

SECTION Z-Z  
 OPTIONAL CONSTRUCTION IF THICKNESS IS GREATER THAN 2.0  
 SCALE 6:1

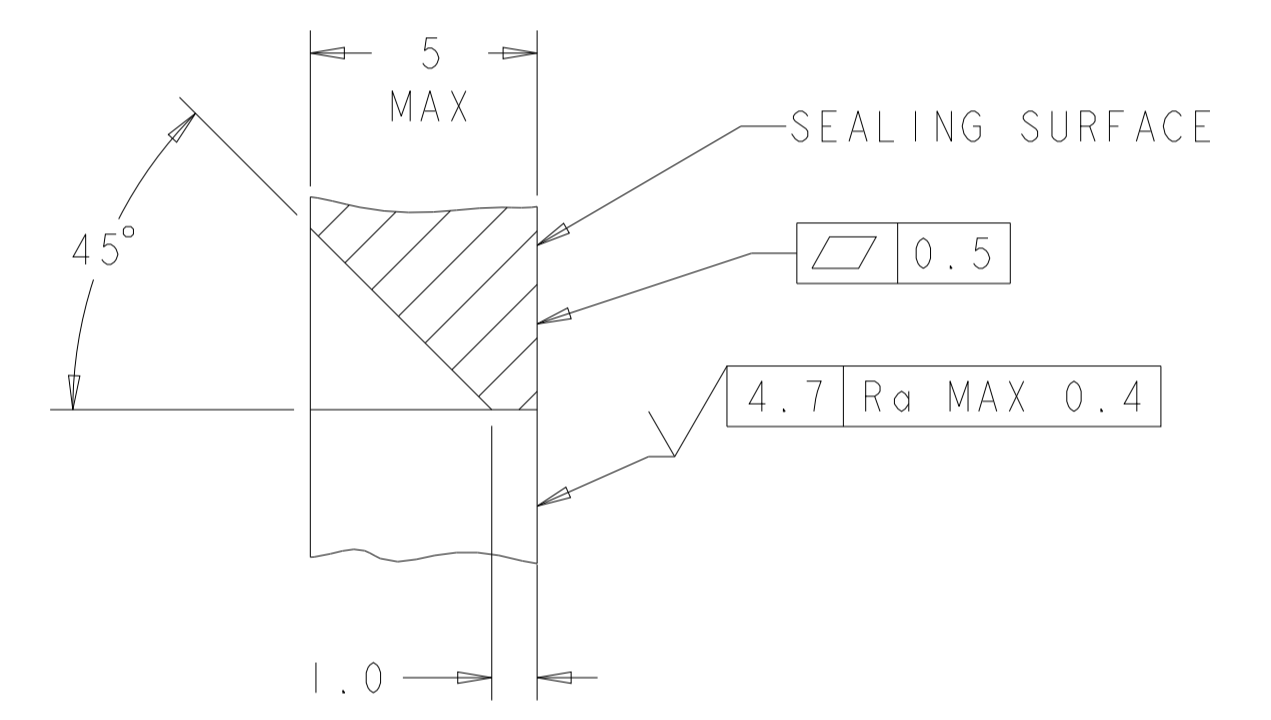

SECTION Z-Z  
 OPTIONAL CONSTRUCTION IF THICKNESS IS GREATER THAN 2.0  
 SCALE 6:1

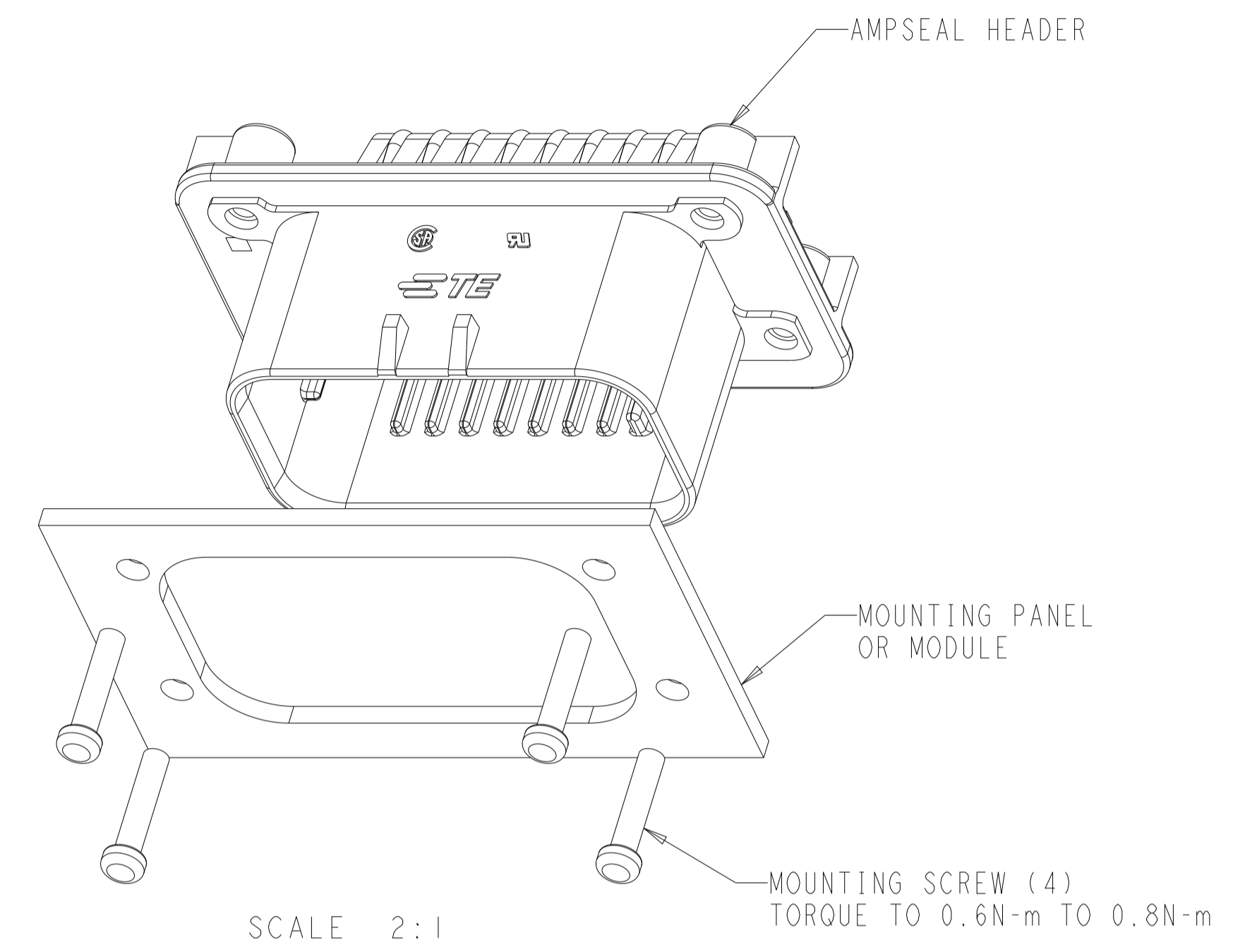

SCALE 2:1

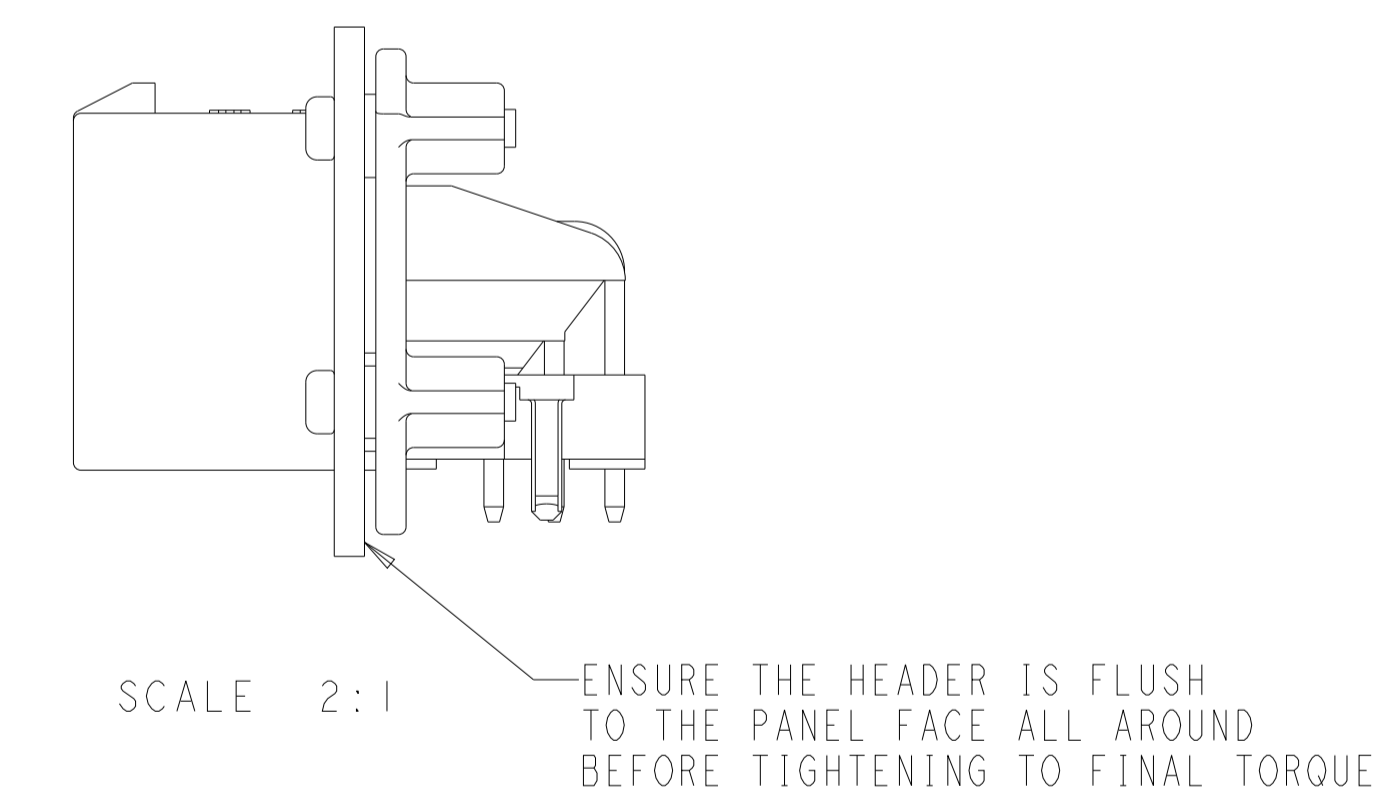

SCALE 2:1

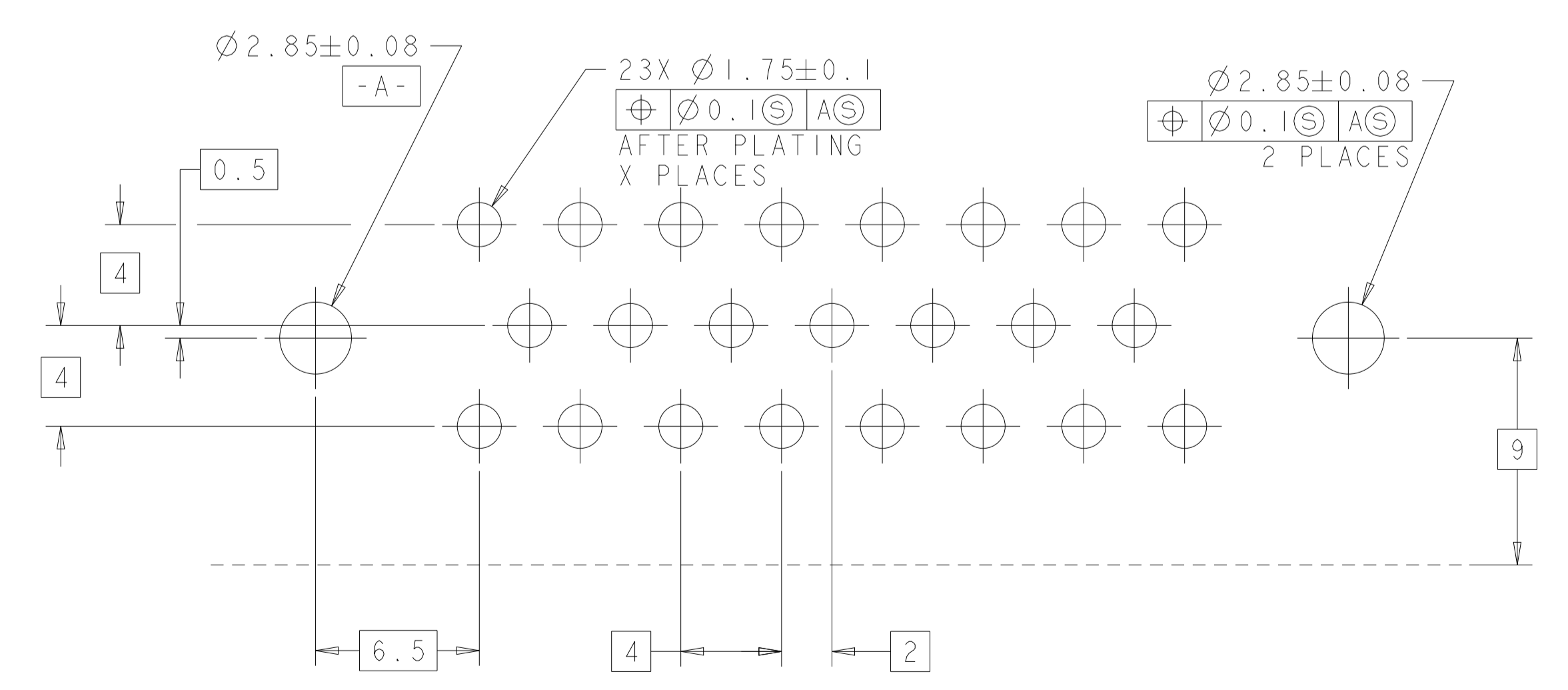

RECOMMENDED P.C. BOARD LAYOUT FOR 1.57 THICK P.C. BOARD

THIS DRAWING IS A CONTROLLED DOCUMENT.		OWN: R. VESTAL 31DEC2002	TE Connectivity
DIMENSIONS: mm		CHK: D. CROWE 31DEC2002	
TOLERANCES UNLESS OTHERWISE SPECIFIED:		APPD: D. CROWE 31DEC2002	NAME: HEADER ASSEMBLY, 23 POSITION, RIGHT ANGLE AMPSEAL
0 PLC	±	PRODUCT SPEC	SIZE: 108-1329
1 PLC	±0.2	APPLICATION SPEC	CAGE CODE: 114-16016
2 PLC	±	FINISH	WEIGHT: 28.74g
3 PLC	±		CUSTOMER DRAWING
4 PLC	±		SCALE: 2:1
ANGLES	±		SHEET: 2 OF 2
			REV: L