

THIS DRAWING IS UNPUBLISHED.
 VERTRAULICH UNVERÖFFENTLICHT ZEICHNUNG
 (C) COPYRIGHT 2003 BY AMP INCORPORATED. ALL RIGHTS RESERVED.
 FREI FÜR VERÖFFENTLICHUNG
 ALLE RECHTE VORBEHALTEN
 MATED WITH:
 PASSEND ZU:

LOC	DIST	REVISIONS					
		P	LTR	DESCRIPTION	DATE	DWN	APVD
AI	-						
PROJEKT NR.: A94-52290		B		ZEICHNUNG NEU ERSTELLT	17-SEP-03	Zayc	Thiel
		C1		ÜBERGANG ZUM CRIMPBEREICH VERSTÄRKT	04-JAN-05	Sche.	Nebe
		C2		KONTUR VON ÜBERGANG ZUM CRIMPBEREICH GEÄNDERT	07-FEB-05	Sche.	Nebe
		C3		KONTUR VON ÜBERGANG ZUM CRIMPBEREICH GEÄNDERT, DRAHT-UND ISOLATIONSGRÖßENBEREICH KORRIGIERT	10-NOV-05	Sche.	R.F.

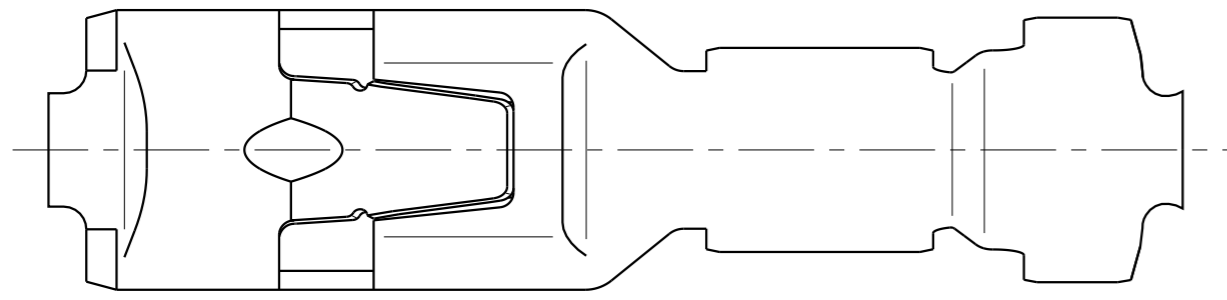

NOTES

- STOCK THICKNESS: 0.25±0.03
- USED FOR TAB 2.8+0.3/-0.1×0.8±0.03
- EXTRACTION TOOL
ORDER NO.: 726519-5
- WIRE RANGE: 1.0-1.5MM², TERMINATED WIRE: FLR, F-CRIMP
- INSULATION RANGE: Ø1.9-2.4MM, OVL-CRIMP
- LOOSE PIECE PART ACC. TO 969177
- PACKAGING: STRIP (10000) ON REEL; 3 REELS PER BOX;
WITH PAPER STRIP

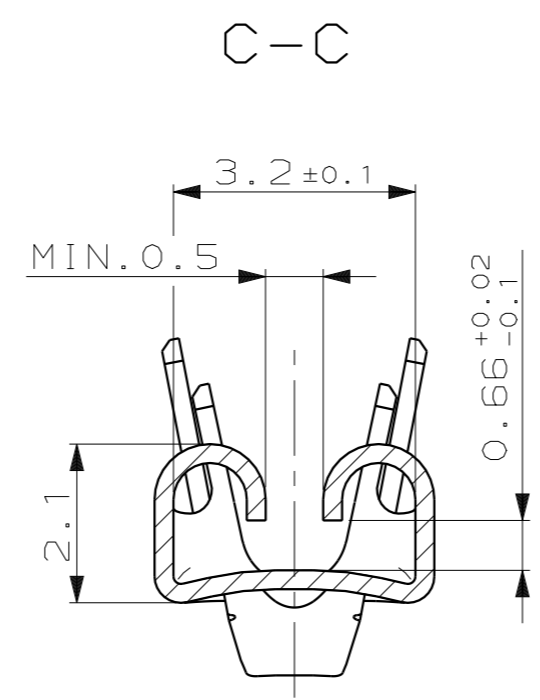
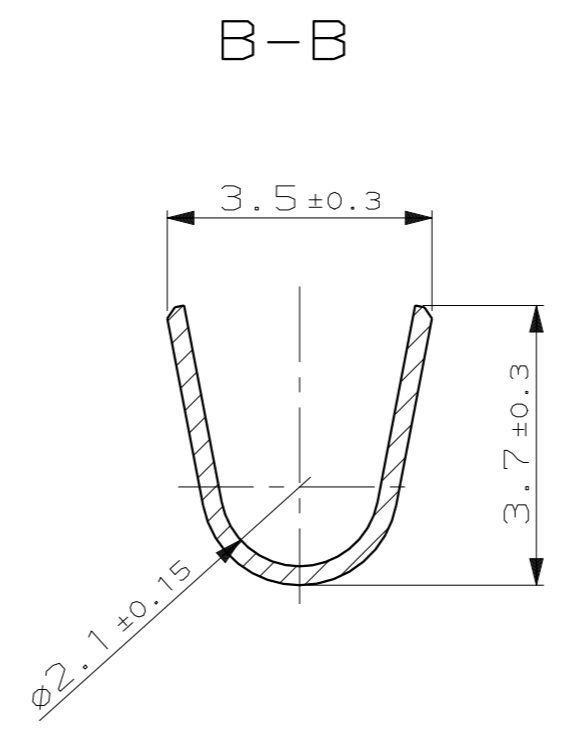
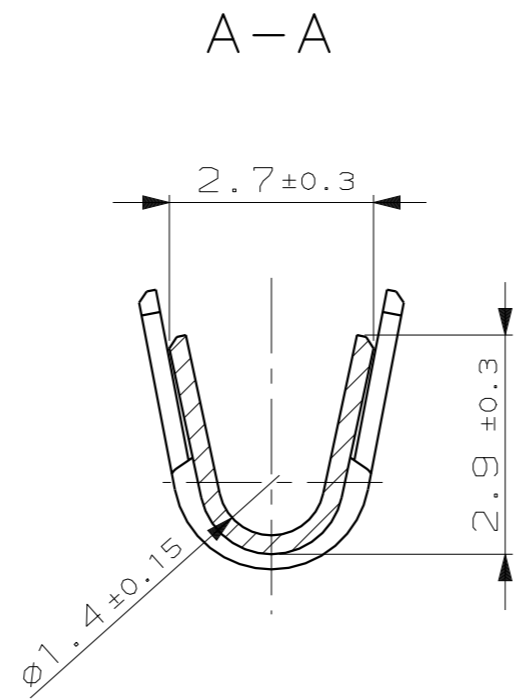
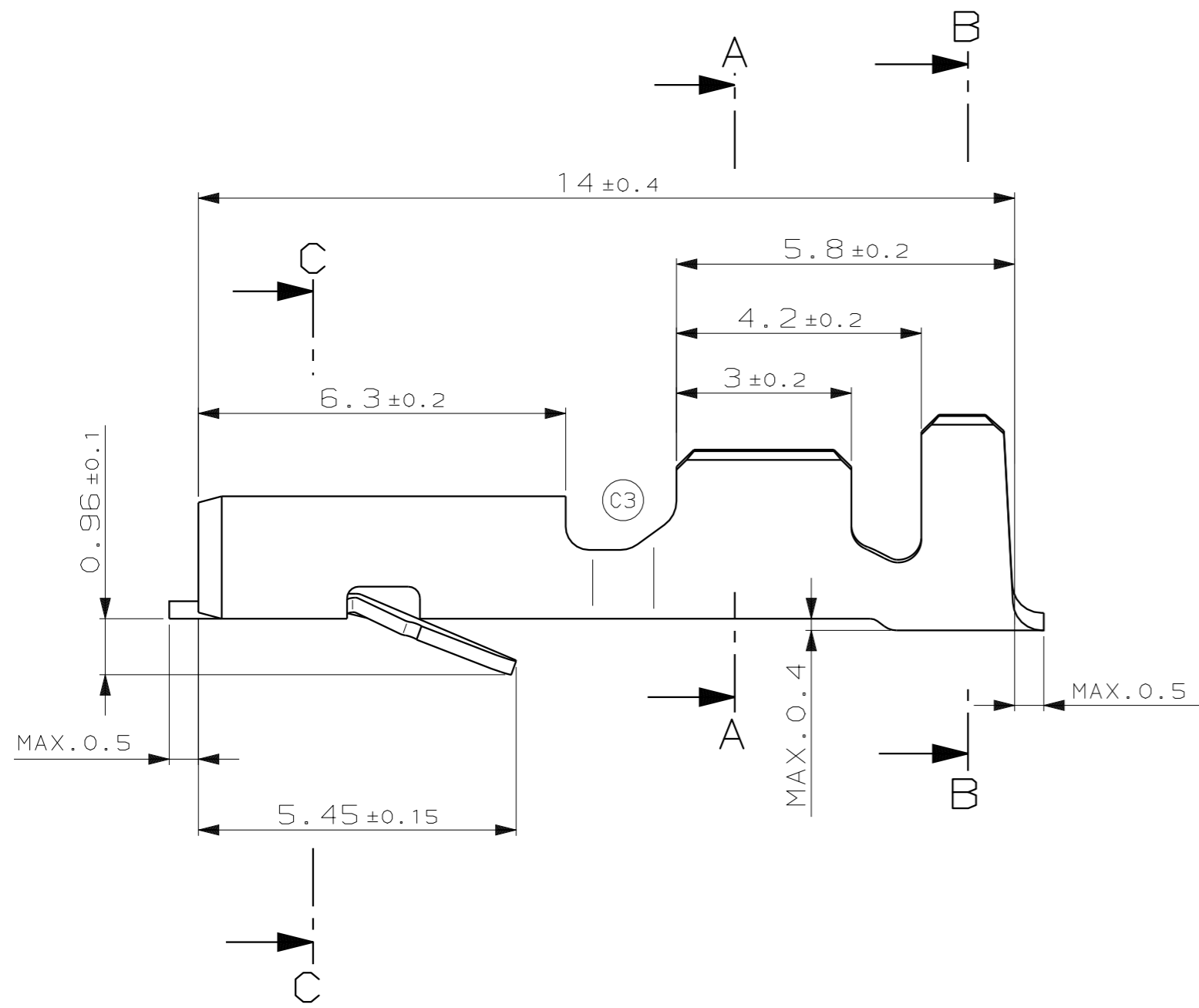

BEMERKUNGEN

- MATERIALDICKE: 0.25±0.03
- GEEIGNET FUER FLACHSTECKER 2.8+0.3/-0.1×0.8±0.03
- AUSDRUECKWERKZEUG
BESTELL-NR.: 726519-5 (C3)
- DRAHTGROESSENBEREICH: 1.0-1.5MM², ANGESCHLAGENER LEITER:
FLR, F-CRIMP (C3)
- ISOLATIONSgroessenbereich: Ø1.9-2.4MM, OVL-CRIMP
- EINZELAUSSFUEHRUNG NACH 969177
- VERPACKUNG: BAND (10000) AUFGEWICKELT; 3 BAENDER PRO BOX;
MIT PAPIERZWISCHENLAGE

969176-1	C	CuNi12Zn24	-	RECEPTACLE, 2.8MM, FASTIN-FASTON	1
TYCO PART NO	REV	MATERIAL	SURFACE COLOR	DESCRIPTION	ITEM NO
<p>THIS DRAWING IS A CONTROLLED DOCUMENT FOR AMP INCORPORATED. IT IS SUBJECT TO CHANGE AND THE CONTROLLING ENGINEERING ORGANIZATION SHOULD BE CONTACTED FOR THE LATEST REVISION. DIESSES ZEICHNUNGSDOKUMENT WIRD DURCH AMP INCORPORATED KONTROLLIERT. AENDERUNGEN, DIE DEM TECHNISCHEN FORTSCHRITT DIENEN, SIND VORBEHALTEN. DEN JEWEILS LETZTUELTIGEN AENDERUNGSSTAND ERFAREN SIE AUF ANFRAGE.</p> <p>DIMENSIONS: mm DIMENSIONEN: mm OTHERWISE SPECIFIED: ±0.15 ALLGEMEINTOLERANZEN 0 PLC ±0.15 1 PLC ± 2 PLC ± 3 PLC ± ANGLES/WINKEL ±1° FINISH/OBERFLAECHE/FARBE</p>					
DWN M.Zayc CHK F.Thiel		17-SEP-03 17-SEP-03		AMP tyco Electronics AMP GmbH D - 64625 Bensheim	
APVD B.Kirsch		17-SEP-03		NAME	
PRODUCT SPEC 108-18638		APPLICATION SPEC VERARBEITUNGSSPEZ.		RECEPTACLE, 2.8MM, FASTIN-FASTON STECKHUELSE, 2.8MM, FASTIN-FASTON	
MATERIAL CuNi12Zn24		WEIGHT -		RESTRICTED TO NUR FUER	
CUSTOMER DRAWING		/KUNDENZEICHNUNG		SIZE A2	
		CAGE CODE 00779		DRAWING NO ZEICHNUNGS-NR. 969176	
		MASSSTAB 10:1		BLATT 1 VON 1	
				REV C3	