

REVISIONS					
P	LTR	DESCRIPTION	DATE	DWN	APVD
H		REVISED PER ECO-20-001327	04JUN2020	SB	JO

$\varnothing 0.38[.015]$  (M)  
TYP AT POST TIPS

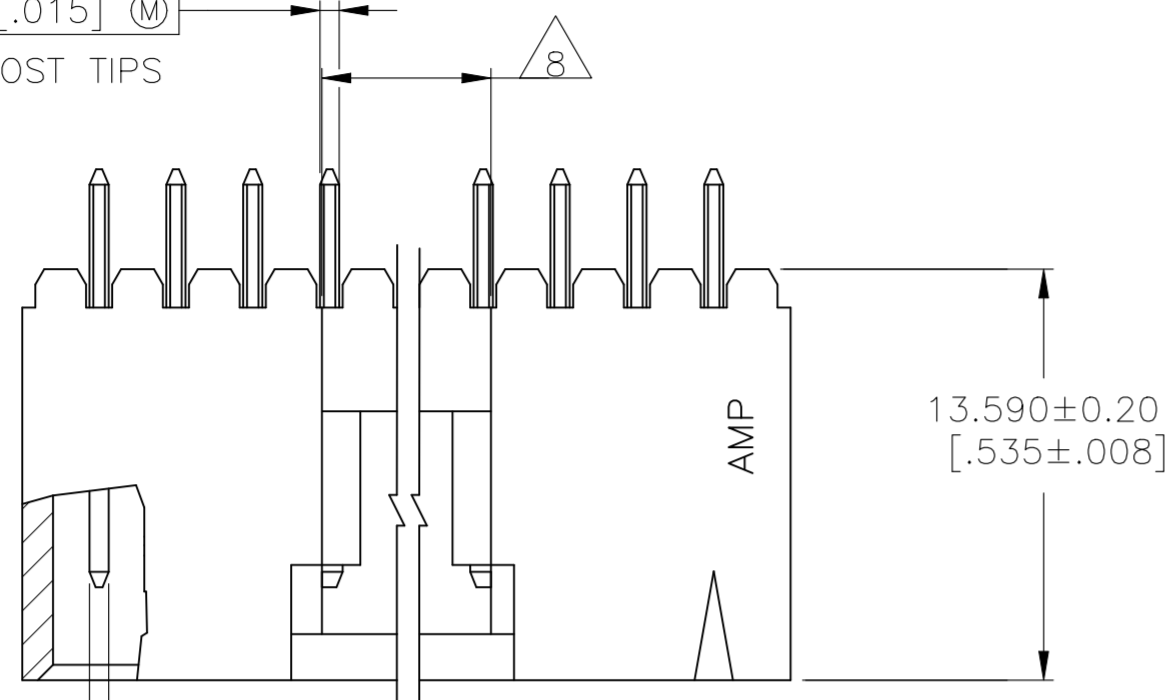

$0.64\pm 0.02$   
[.025±.001]

$\varnothing 0.38[.015]$  (M)  
TYP AT POST TIPS

- 1 .00038[.000015] GOLD IN THE CONTACT AREA, .00254[.000100] MATTE TIN-LEAD ON REMAINDER OF CONTACT, ALL OVER .00127[.000050] NICKEL.
- 2 POINT OF MEASUREMENT FOR PLATING THICKNESS.
- 3 THE NOTED DIMENSIONS APPLY AT THE INTERSECTION OF THE POST AND THE HOUSING.
- 4 ON ASSEMBLIES WITH FOUR OR MORE POSITIONS, TWO POLARIZATION SLOTS. ON ASSEMBLIES WITH TWO OR THREE POSITIONS, ONE POLARIZATION SLOT.
- 5 .00038[.000015] GOLD IN THE CONTACT AREA, .00254[.000100] MATTE TIN ON REMAINDER OF CONTACT, ALL OVER .00127[.000050] NICKEL.
- 6 HIGH TEMPERATURE CONFIGURATION.
- 7 STANDOFF NOT PRESENT ON UNDERSIDE OF ASSEMBLY
- 8 0.25 [.010] RECESS PERMISSIBLE IN THIS AREA FOR MOLD SHUT OFF

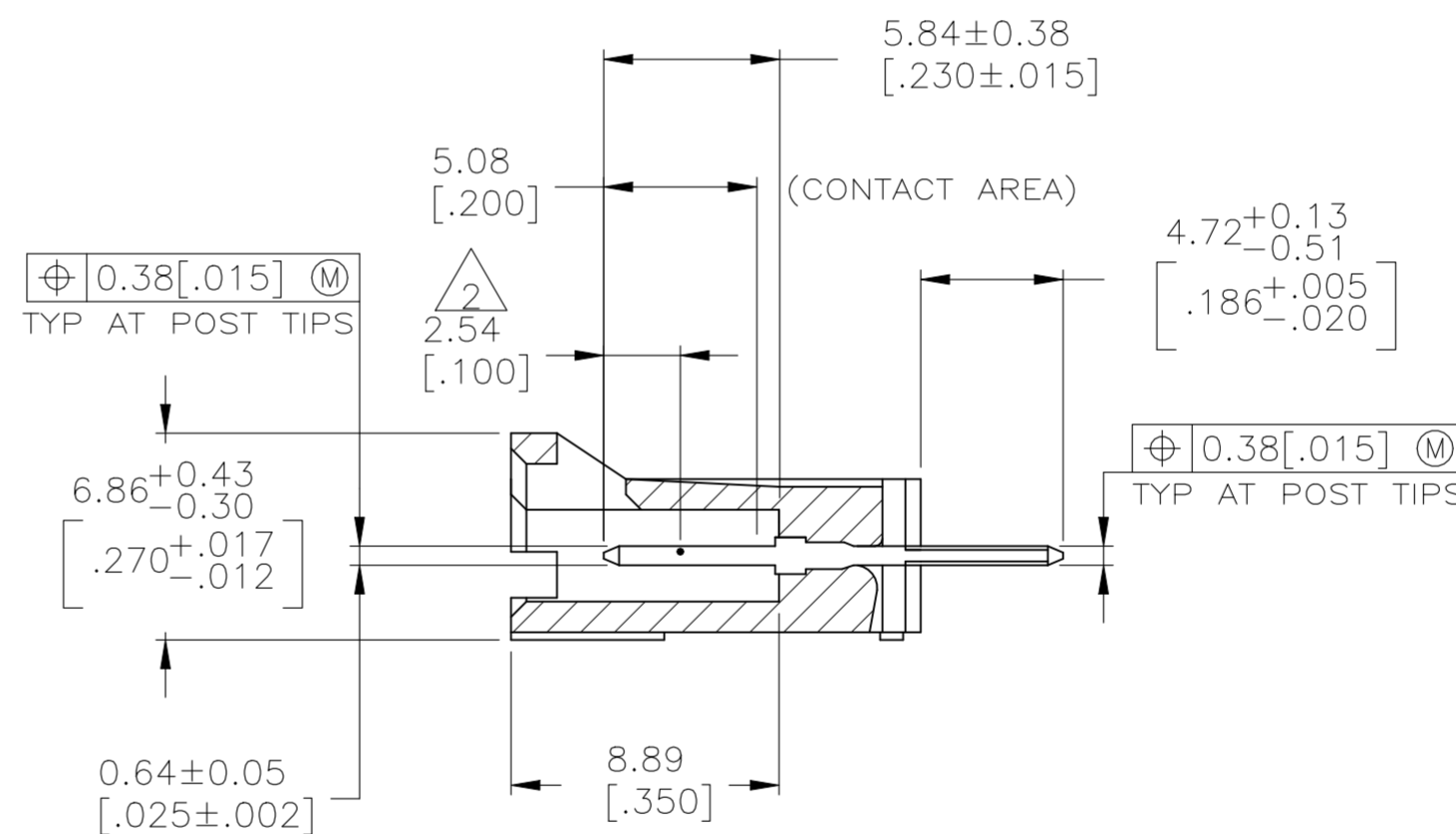
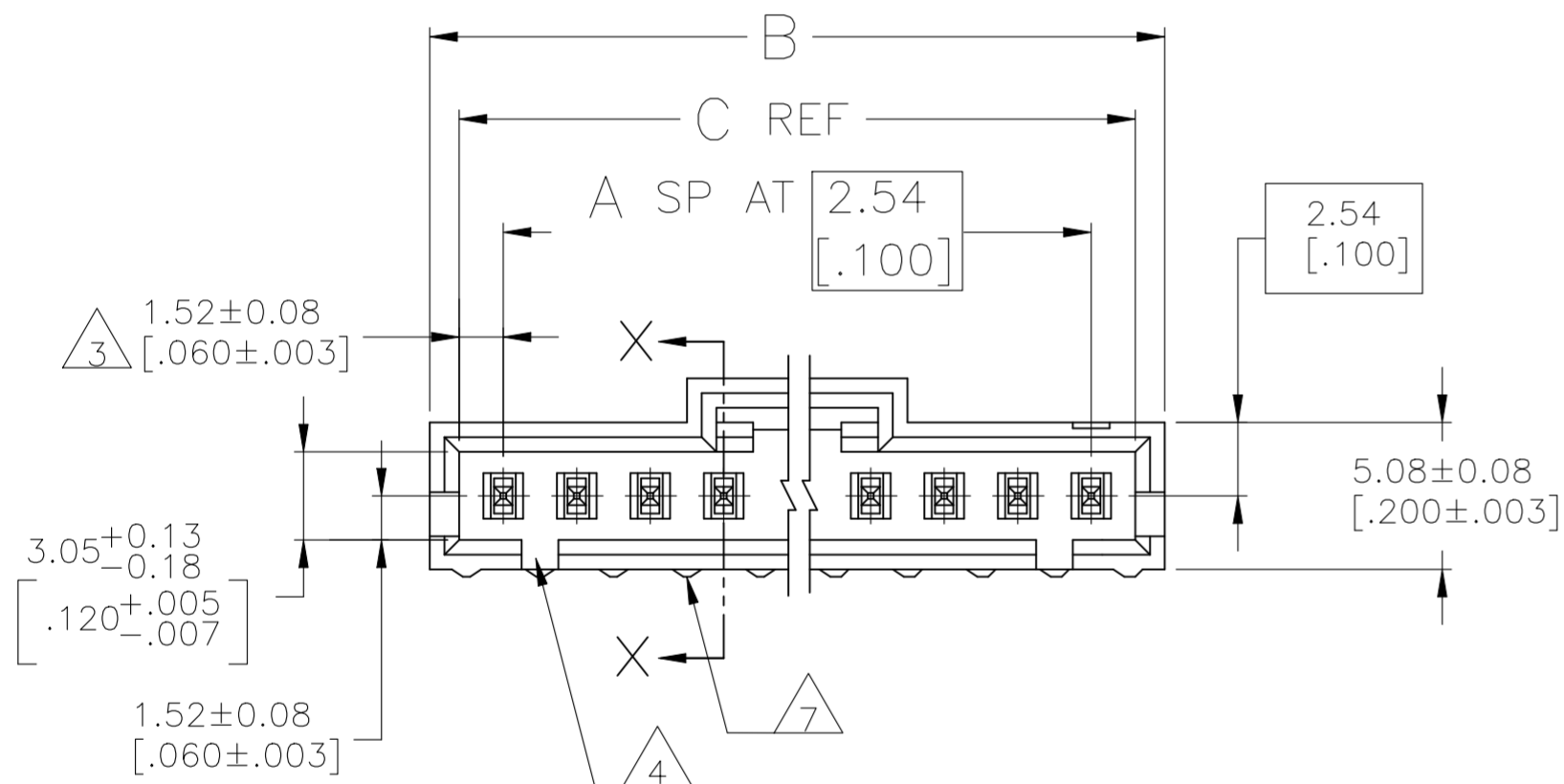

SECTION X-X

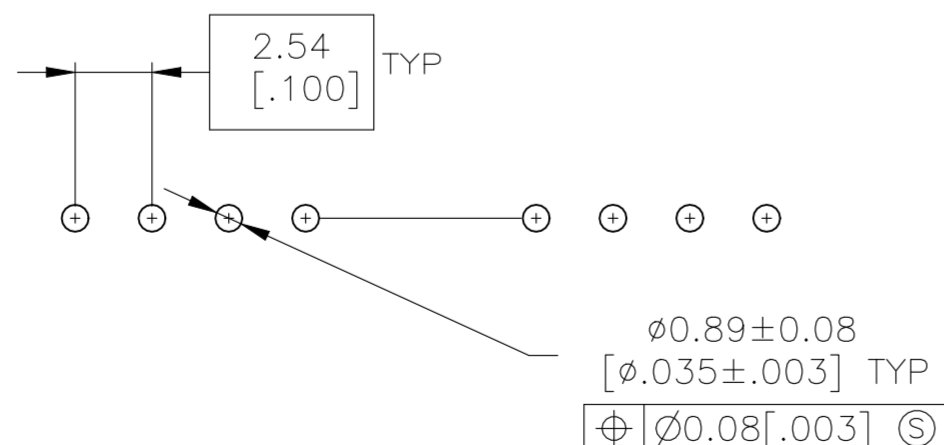

RECOMMENDED HOLE LAYOUT

6 7	5	13.21 [.520]	15.11 [.595]	4	5	5-104911-1
6	1	13.21 [.520]	15.11 [.595]	4	5	104911-1
REMARKS	PLATING	C	B	A	NO. OF POSN	PART NO.

THIS DRAWING IS A CONTROLLED DOCUMENT.		DWN E. BRANDBERG 13-6-94				
DIMENSIONS: mm [INCHES]		CHK J.GESFORD 13-6-94				
TOLERANCES UNLESS OTHERWISE SPECIFIED:		APVD J.GESFORD 13-6-94	NAME			
0 PLC ± -	1 PLC ± -	PRODUCT SPEC	HDR ASSY, VERT, SINGLE ROW			
2 PLC ± 0.13[.005]	3 PLC ± -	APPLICATION SPEC	2.54[.100] C/L, 0.64[.025] SQ POST,			
4 PLC ± -	ANGLES ± -	108-25034	SIZE	CAGE CODE	DRAWING NO	RESTRICTED TO
MATERIAL: HOUSING: FLAME RETARDANT LCP, COLOR - BLACK CONTACTS: BRASS		FINISH SEE TABLE	114-25026	A2	00779	C=104911
		WEIGHT	-	SCALE	4:1	SHEET 1 OF 1
		CUSTOMER DRAWING		REV	H	