

REVISIONS					
P	LTR	DESCRIPTION	DATE	DWN	APVD
E		REVISED PER ECN-23-217596	30JUN2023	LP	RL

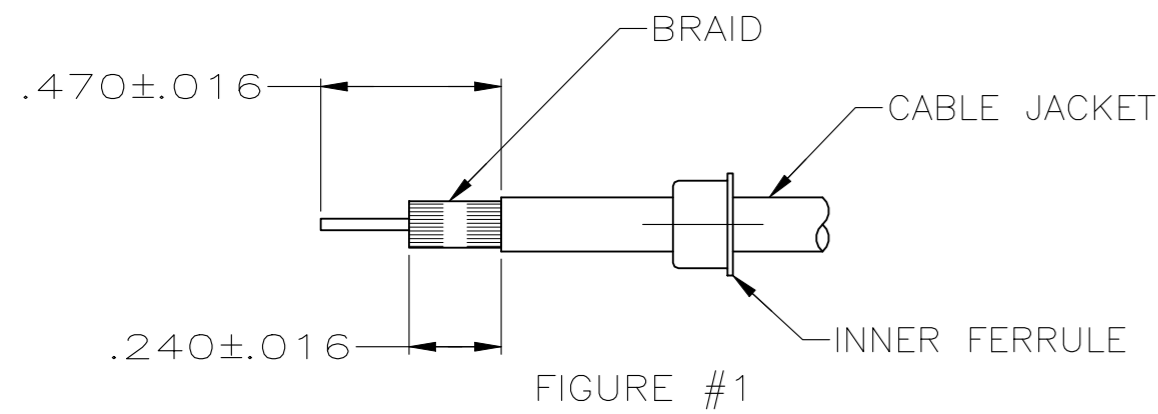

1. CABLE PREPARATION:

- A. SLIDE INNER FERRULE ONTO CABLE MAKING SURE TO KEEP THE LARGER DIAMETER OF INNER FERRULE OPPOSITE FROM THE END OF THE CABLE BEING TERMINATED. (SEE FIGURE #1)
- B. STRIP OUTER JACKET AND BRAID AS INDICATED IN FIGURE #1. CARE SHOULD BE TAKEN NOT TO NICK OR CUT THE BRAID STRANDS DURING THE REMOVAL OF THE JACKET.
- C. EVENLY FLARE THE BRAID BACK OVER THE OUTER JACKET AND CUT CENTER CONDUCTOR & DIELECTRIC WITHIN THE LIMITS INDICATED IN FIGURE #2.
 (1) CARE SHOULD BE TAKEN NOT TO NICK OR CUT INDIVIDUAL CONDUCTORS DURING REMOVAL OF DIELECTRIC.
 (2) INDIVIDUAL CONDUCTORS SHOULD BE TWISTED TIGHTLY TO ELIMINATE LOOSE WIRE STRANDS.

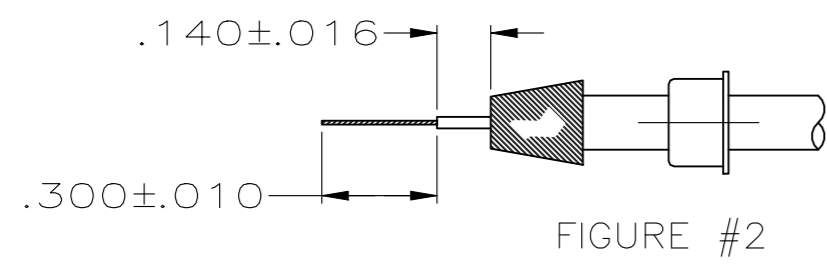

SCALE 2:1

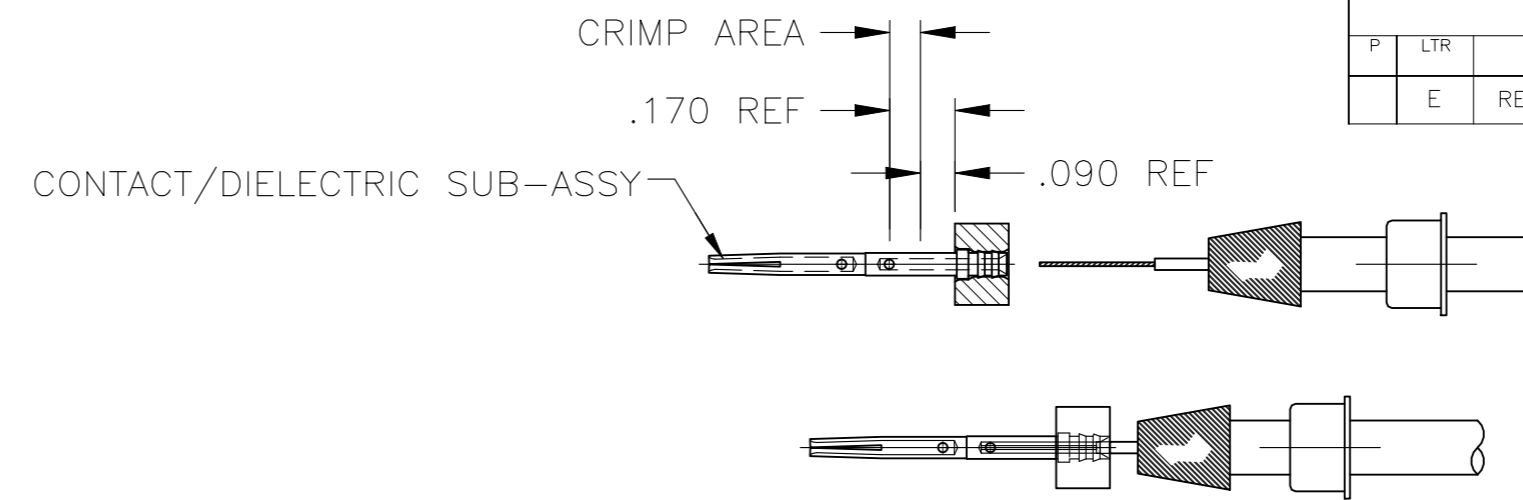

FIGURE #3

2. CRIMPING:

- A. CENTER CONDUCTOR- CRIMP CENTER CONDUCTOR USING DANIELS MFG CORP 4-8 INDENT HANDTOOL M22520/2-01. THE HANDTOOL CRIMP SELECTOR SHOULD BE SET TO #5. NO LOCATOR IS NECESSARY. INSERT THE CONTACT/DIELECTRIC SUB-ASSEMBLY INTO HANDTOOL. THE DIELECTRIC WILL POSITION THE CENTER CONTACT. INSERT THE CENTER CONDUCTOR INTO CONTACT WIRE BARREL. THE TIP OF THE STRIPPED WIRE SHOULD BE VISIBLE IN THE WIRE BARREL SIGHT HOLE. CRIMP AND REMOVE CENTER CONTACT. SEE FIGURE #3.
- B. INSERT THE CRIMPED CENTER CONTACT AND CABLE INTO OUTER CONTACT BODY. SLIDE FERRULE INTO OUTER CONTACT BODY CAPTURING TRIMMED BRAID BETWEEN FERRULE AND SHELL BODY.
- C. FERRULE CRIMP- PLACE CONTACT ASSEMBLY INTO AMP HAND CRIMPING TOOL 354940-1 & DIE SET 91907-1 AND BOTTOM FRONT END OF CRIMP END FERRULE ON THE CRIMPER. COMPLETE CRIMPING AND RELEASE CONTACT. SEE FIGURE #4.
- D. AFTER CRIMPING, THE DIAMETER ACROSS THE $\phi 200$ DIMENSION, SHOWN IN FIGURE #4 SHOULD BE .273-.276.

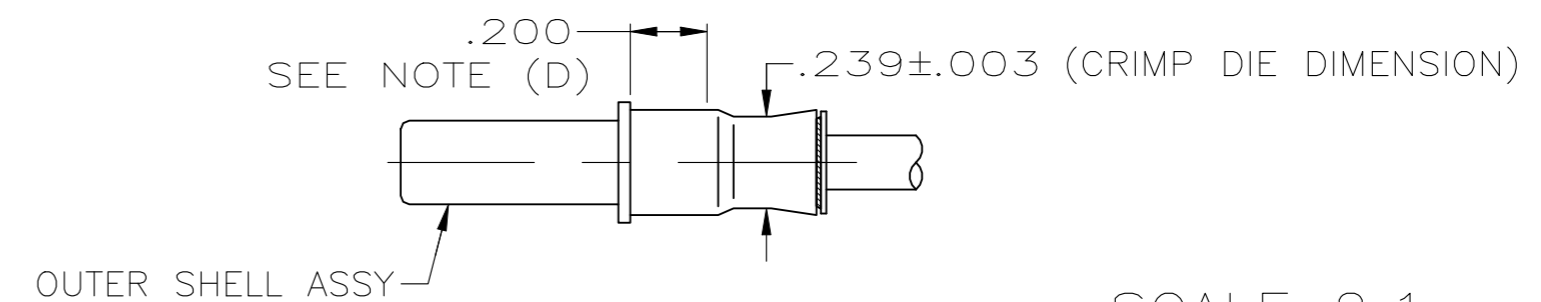
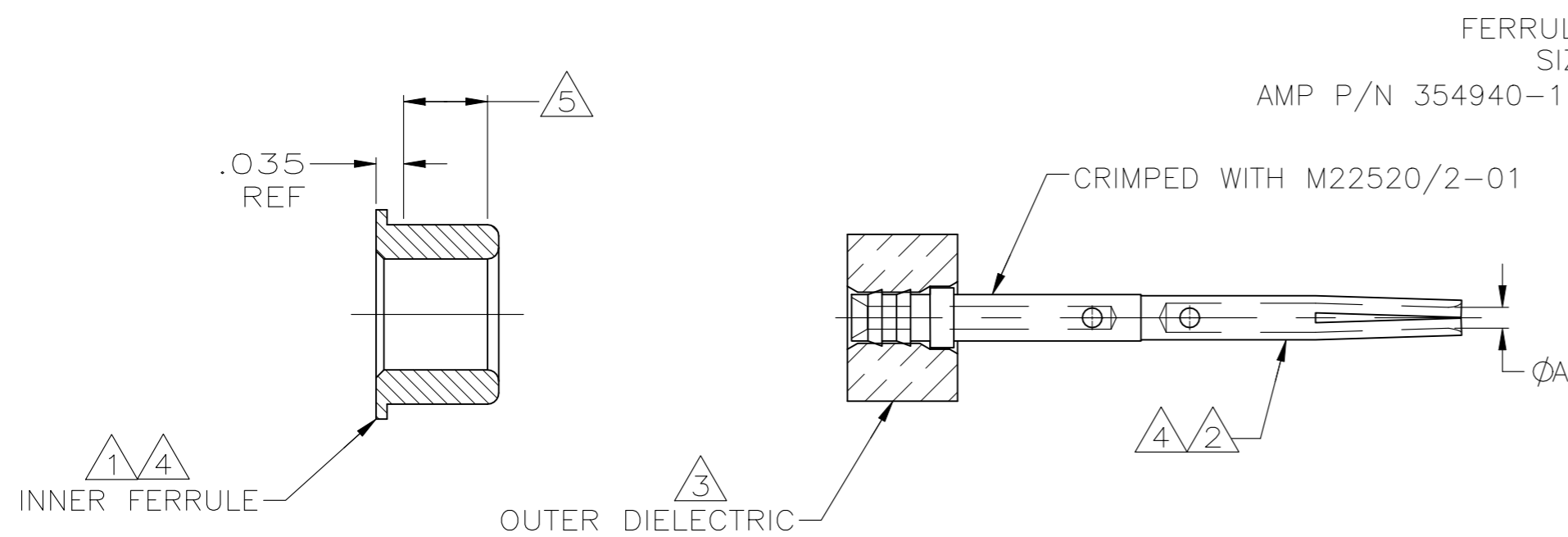
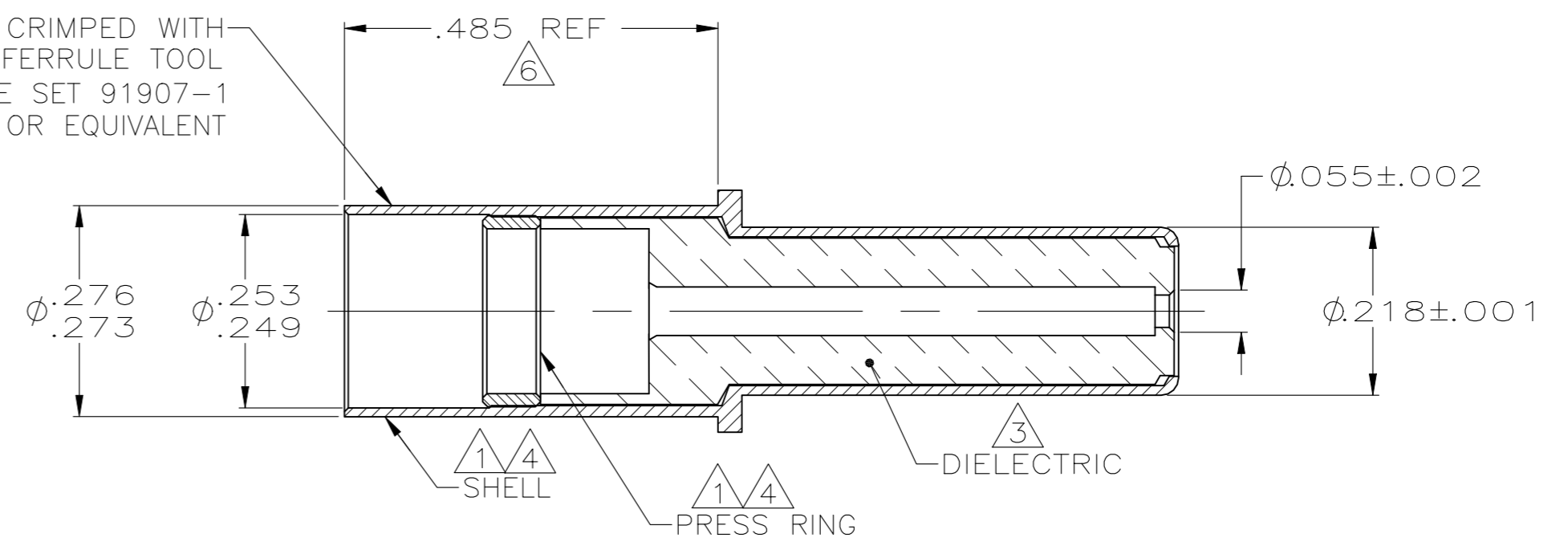

FIGURE #4

SCALE 2:1



FERRULE IS CRIMPED WITH SIZE 8 FERRULE TOOL AMP P/N 354940-1 & DIE SET 91907-1 OR EQUIVALENT



SUPERSEDED BY 1218687-3	.034 REF; MATES TO $\phi 040$ PIN	1218687-3
	.027 REF; MATES TO $\phi 030$ PIN	1218687-1
	DIM ϕA	PART NUMBER

- ① MAT'L: BRASS PER ASTM-B-16
- ② MAT'L: BERYLLIUM COPPER PER ASTM-B-196.
- ③ MAT'L: PTFE PER ASTM-D-1710.
- ④ FINISH: GOLD PLATE PER MIL-G-45204, TYPE 1, GRADE C, CLASS 1 OVER NICKEL .000050 THK PER QQ-N-290, CLASS 2.
- ⑤ 160 DP. FULL DIAMOND KNURL OVER THIS LENGTH.
- ⑥ .533 AFTER TERMINATION TO CABLE.

THIS DRAWING IS A CONTROLLED DOCUMENT.		DWN	C.C.THOMAS	9-6-00
DIMENSIONS: INCHES		CHK	R.GROSS	9-6-00
TOLERANCES UNLESS OTHERWISE SPECIFIED:		APVD	R.GROSS	9-6-00
0 PLC	± -	PRODUCT SPEC		
1 PLC	± -	APPLICATION SPEC		
2 PLC	± -			
3 PLC	± -			
4 PLC	± -			
ANGLES	± -			
MATERIAL: SEE CALLOUTS	FINISH: SEE CALLOUTS	WEIGHT	0.000000	A2 00779
CUSTOMER DRAWING		SCALE	5:1	SHEET 1 OF 1