

REVISIONS

P	LTR	DESCRIPTION	DATE	DWN	APVD
	D	ECO-15-008379	27OCT2021	RZ	WK

NOTES:

- 1 PACK IN ACCORDANCE WITH AMP SPEC 107-3275
- 2 100 TRAY PACK IN ACCORDANCE WITH AMP SPEC 107-3275
- 3 Au PLATING
- 4 Ni PLATING
- 5 THIS ITEM MUST BE WHITE
- 6 HAND TOOL : 9-1478240-0
- 7 DIE SET : 9-1478242-0
- 8 ELECTRICAL CHARACTERISTICS
 FREQUENCY RANGE: DC - 4 GHz
 NOMINAL IMPEDANCE: 50 Ohm
 INSULATION RESISTANCE: 5000 MOhm
 WORKING VOLTAGE: 500 Volts RMS at Sea Level
 DIELECTRIC WITHSTAND VOLTAGE: 1500 Volts RMS Max
 CONTACT RESISTANCE:
 CENTRE CONTACT: 1.50 mOhm Max
 OUTER CONTACT: 0.20 mOhm Max
 VSWR @ 4GHz: 1.35:1 Max
 INSERTION LOSS dB @ x 3 GHz: 0.30 Max
- 9 MECHANICAL CHARACTERISTICS
 COUPLING RETENTION FORCE: 445N Min
 CABLE RETENTION FORCE: 128N Min
 DURABILITY: 500 Cycles Min
- 10 ENVIRONMENTAL CHARACTERISTICS
 OPERATING TEMPERATURE: -65 to +165 DegC
- 11 FOR TECHNICAL DATA REFER TO YOUR LOCAL TYCO ELECTRONICS SALES OFFICE
- 12 ALL DIMENSIONS ARE NOMINAL FOR REFERENCE ONLY UNLESS OTHERWISE STATED

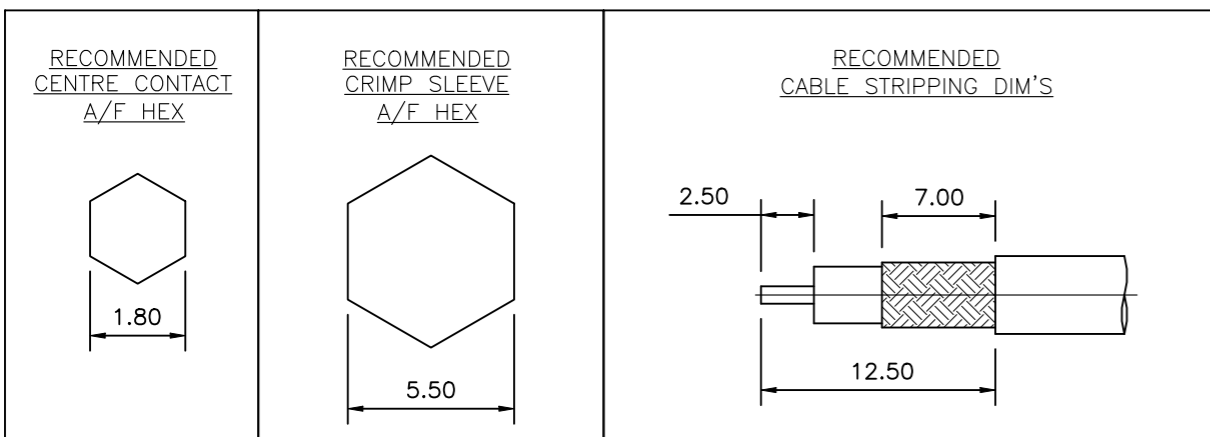
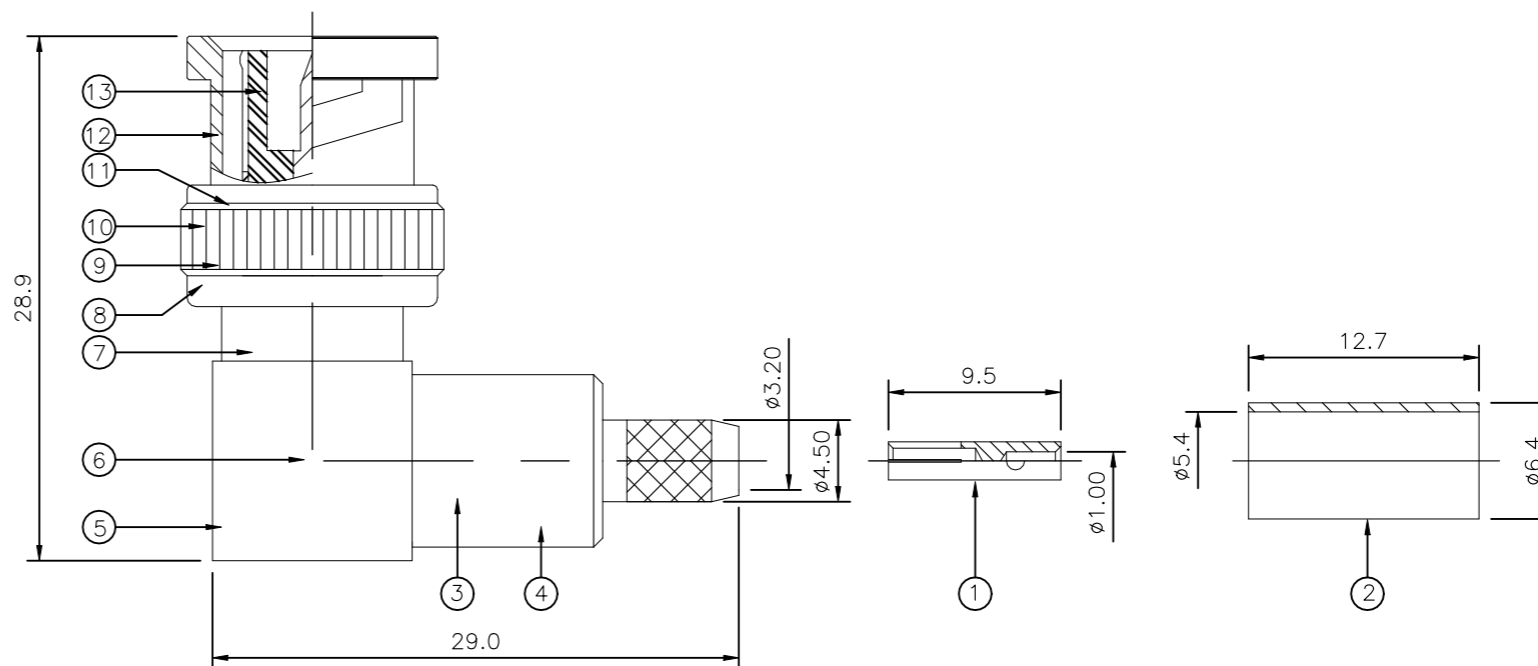

QTY	REV	PART NO	MATERIAL	DESCRIPTION	ITEM
1	1		PTFE	INSULATION	13
1	1		BRASS	4 SHELL	12
1	1		SILICON RUBBER	5 GASKET	11
1	1		BRASS	4 WASHER	10
1	1		SPRING STEEL	4 SPRING	9
1	1		BRASS	4 WASHER	8
1	1		BRASS	4 BODY 2	7
1	1		BRASS	3 CONTACT II	6
1	1		BRASS	4 BODY 1	5
1	1		BRASS	4 CHASSIS	4
1	1		PTFE	INSULATION	3
1	1		BRASS	4 FERRULE	2
1	1		BRONZE	3 CONTACT I	1
6--0	1--0		MATERIAL	DESCRIPTION	ITEM
2	1				
QUANTITY PER ASSY			PARTS LIST		

THIS DRAWING IS A CONTROLLED DOCUMENT.		DWN J.SANDWELL 25AUG06	TE Connectivity BNC ELBOW PLUG CRIMP 50 OHM RG58C/U, 141A/U, URM43, 76, KX15				
		CHK S.PARLOW 25AUG06					
		APVD F.WHEELER-KING 25AUG06					
		PRODUCT SPEC -					
DIMENSIONS: mm		TOLERANCES UNLESS OTHERWISE SPECIFIED:	NAME	SIZE	CAGE CODE	DRAWING NO	RESTRICTED TO
		0 PLC ± - 1 PLC ± 0.3 2 PLC ± 0.2 3 PLC ± - 4 PLC ± - ANGLES ± -		411-3247	A3	00779	C-1337544
MATERIAL SEE TABLE		FINISH -	APPLICATION SPEC -	WEIGHT 0.000000	CUSTOMER DRAWING		SCALE NTS
						SHEET 1 OF 1	REV D