

THIS DRAWING IS UNPUBLISHED. RELEASED FOR PUBLICATION 20
 © COPYRIGHT 20 TE CONNECTIVITY ALL RIGHTS RESERVED.

LOC	DIST	REVISIONS					
		P	LTR	DESCRIPTION	DATE	DWN	APVD
-	-	A8		ADDED THE TORQUE GAP RANGE	30APR2015	LW	PY
		B		ECR-17-016898	11JAN2018	FF	MS

1 SPECIFICATION

CABLE CONDUCTOR SIZE	4.0MM2/AWG12	6.0MM2/AWG10
RATED CURRENT (AT 85°C AMBIENT)	UL 20A DC TUV 35A DC	UL 30A DC TUV 40A DC
RATED VOLTAGE	1000V DC / TUV 1000V DC	
DEGREE OF PROTECTION,MATED	IP 68 (1m,24h)	
AMBIENT TEMPERATURE RANGE	-40°C ~+85°C	
OVERVOLTAGE CATEGORY	III	
POLLUTION DEGREE	2	
CONTACT RESISTANCE	0.5mΩ	
CONTACT MATERIAL	COPPER,TIN PLATED	
INSULATION MATERIAL	THERMOPLASTIC, UL94-V0	
SAFETY CLASS	II	
STRIP LENGTH	6.5mm	
CABLE JACKET DIAMETER	5.5~7.8mm	

- 2 CONTACT SHOWN UNINSTALLED, FOR REFERENCE ONLY
- 3 USE ONLY CRIMP TOOL OF TE CONNECTIVITY TO CRIMP CONTACT. CRIMP TOOL P/N 6-1579014-8
- 4 THE CABLE SCREW JOINT TORQUE GAP:

CABLE OD(mm)	TORQUE GAP(mm)
5.5~<=6.0	1.60±0.25
6.0~<=6.5	1.25±0.25
6.5~<=7.0	1.65±0.25

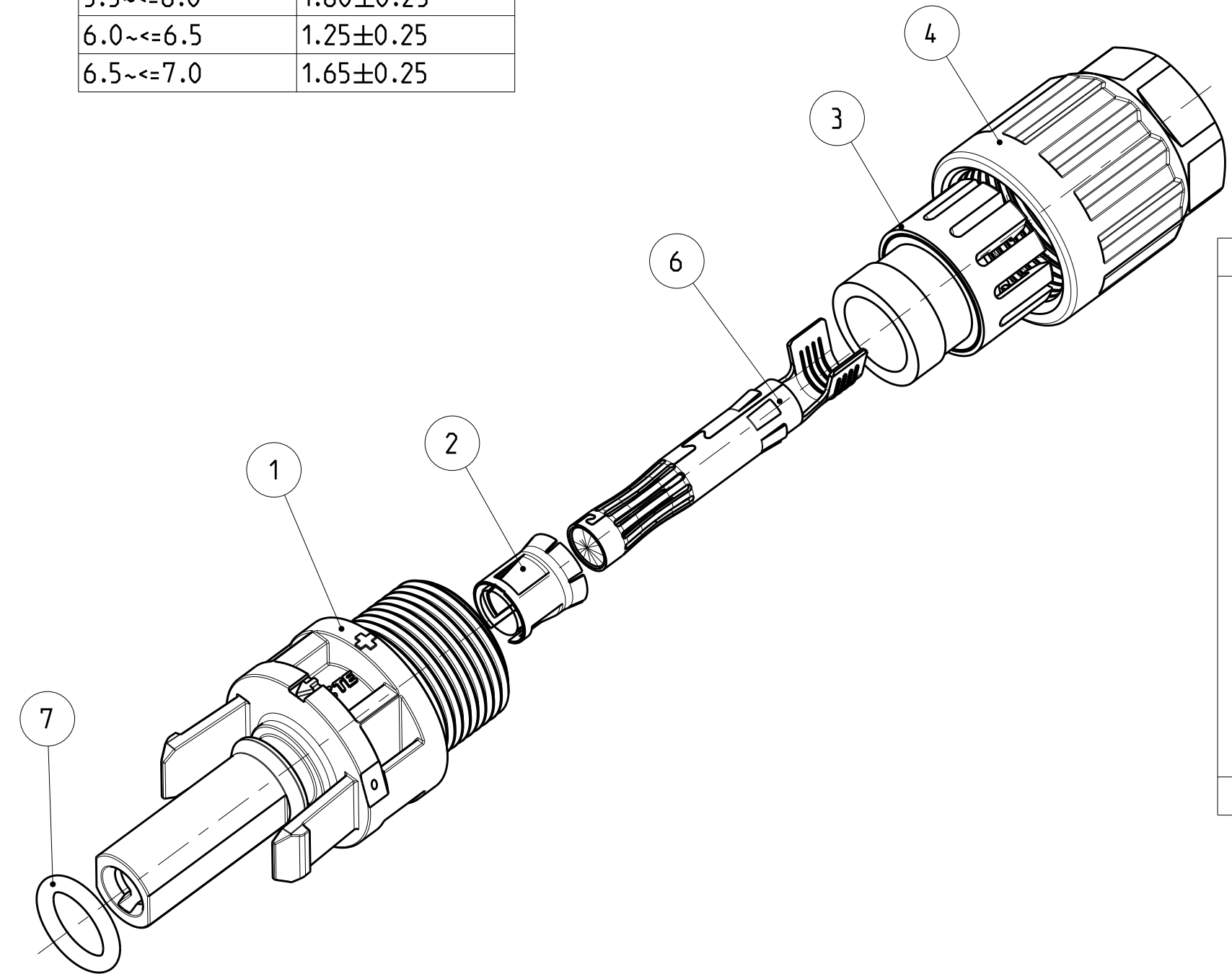

CONNECTOR ASSEMBLY SHOWN EXPLODED VIEW FOR REFERENCE ONLY

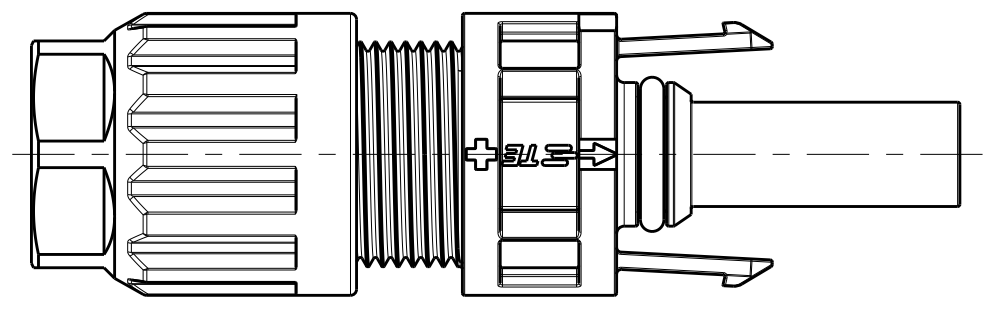

PREASSEMBLED VIEW AS SHOWN

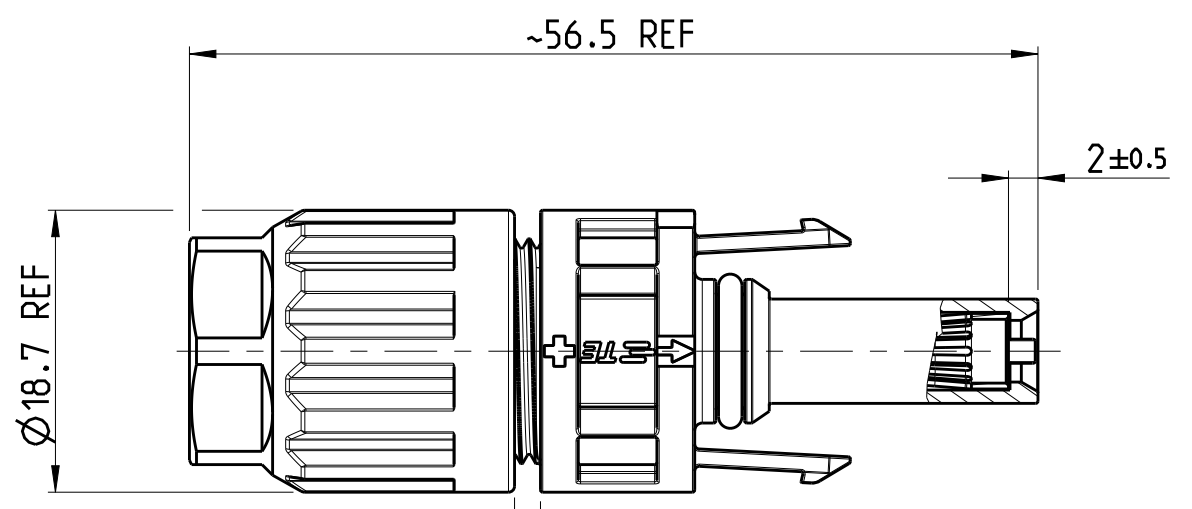

ASSEMBLED VIEW AS SHOWN AND VIEW SHOWS THE TORQUE GAP FOR REFERENCE ONLY

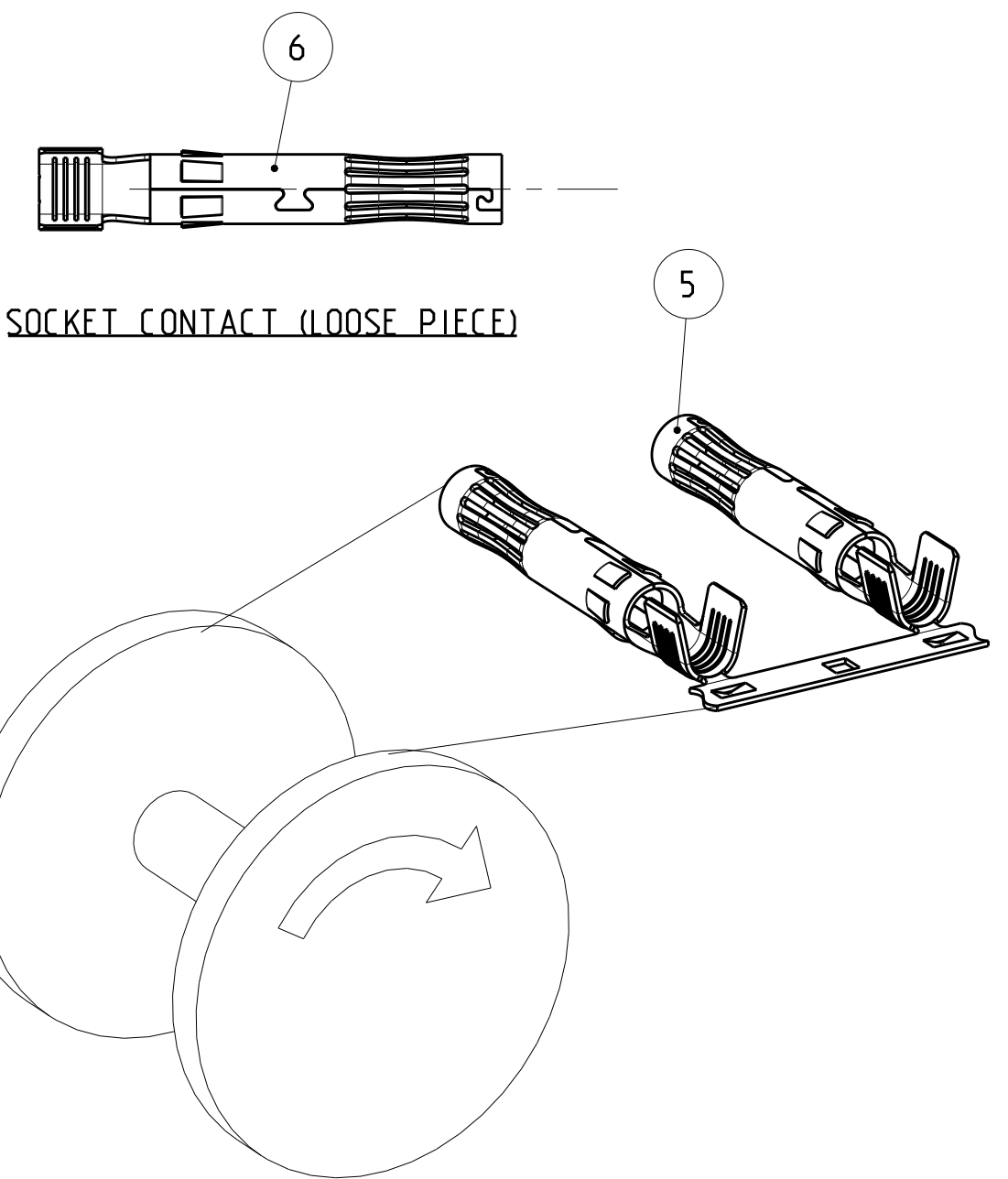

STRIP CONTACT COME OFF TO ASSEMBLY 2000 PCS CONTACTS MOUNTED REEL REEL TYPE SUBJECT TO ALTERNATION -1 AS SHOWN

										PART NUMBER		
										PACKAGING QTY.		
										CABLE JACKET DIAMETER in mm		
4- -2	4- -1	3- -2	3- -1	2- -2	2- -1	1- -2	1- -1	-2	-1			
1	10	100	2000	1000								
5.5~6.0	6.0~7.8	5.5~6.0	6.0~7.8	5.5~6.0	6.0~7.8	5.5~6.0	6.0~7.8	5.5~6.0	6.0~7.8			
1	1	1	1	1	1	1	1	1	1	O-RING, 7.1X1.55 (RED)	7	
1	1	1	1	1	1	-	-	-	-	SOCKET CONTACT, 4~6mm ² /10~12AWG, LOOSE PIECE	6	
-	-	-	-	-	-	1	1	-	-	SOCKET CONTACT, 4~6mm ² /10~12AWG, STRIP	5	
1	1	1	1	1	1	1	1	-	-	CABLE SCREW JOINT	4	
1	1	1	1	1	1	1	1	-	-	PINCH RING SEAL INMOLDED, ASSY	3	
1	1	1	1	1	1	1	1	-	-	METAL CLIP	2	
1	1	1	1	1	1	1	1	-	-	PV4 SOCKET CONNECTOR, PLUS CODED	1	
QUANTITY PER ASSEMBLY										DESCRIPTION	ITEM No	

THIS DRAWING IS A CONTROLLED DOCUMENT.

DIMENSIONS: mm

TOLERANCES UNLESS OTHERWISE SPECIFIED:

0 PLC	±
1 PLC	±
2 PLC	±
3 PLC	±
4 PLC	±
ANGLES	±
FINISH	±

MATERIAL: -

APPROVALS:

DWN	FRANK FAN	11JAN2018
CHK	ALEX CHEN	11JAN2018
APVD	MING SHI	11JAN2018

PRODUCT SPEC: 108-106078

APPLICATION SPEC: 114-106078

WEIGHT: -

Customer Drawing

SCALE: 2:1

SHEET 1 OF 1

REV B

NAME: SOCKET CONNECTOR KITS (FEMALE) (PV4-B*) SOLARLOK PV4 CONNECTOR

SIZE: A2

CAGE CODE: 00779

DRAWING NO: C-1971862

RESTRICTED TO: -