

LOC	DIST	REVISIONS			
		REV	DATE	BY	CHKD
GP	00	D	23MAR2012	JY	AC
		E	6AUG2014	RG	MC
		F	30EC2014	RG	MC
		F1	19JAN2021	SH	SZ

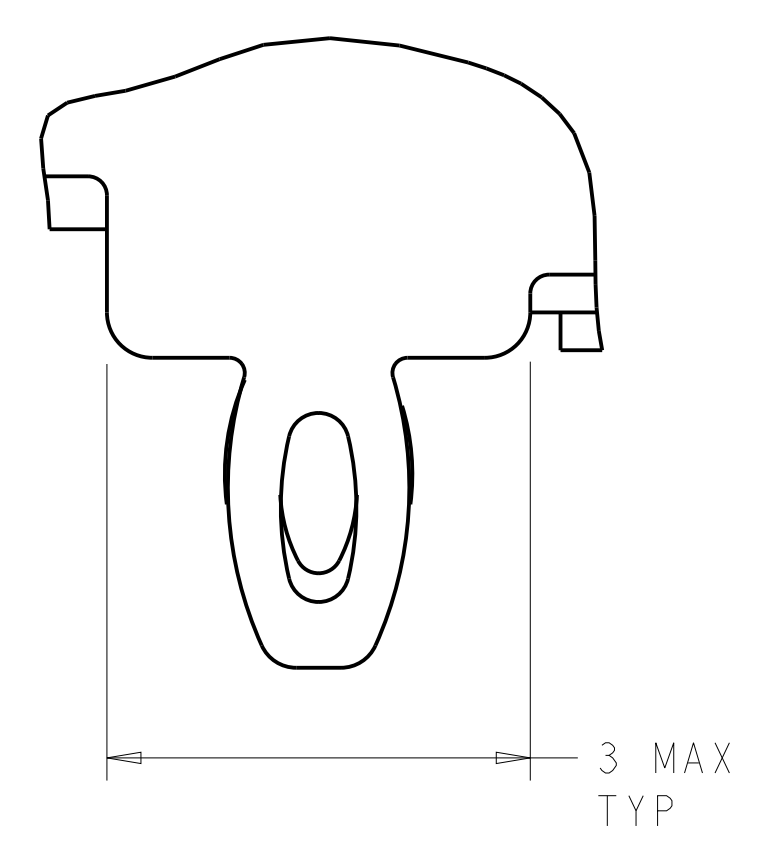

DETAIL S $\Delta 12$
 SCALE 20:1

- $\Delta 1$ MATERIALS:
 CAGE ASSEMBLY: NICKEL SILVER, 0.25 THICK
 EMI SPRINGS: COPPER ALLOY
 FRONT FLANGE: ZINC ALLOY
 HEAT SINK: ALUMINUM/NICKEL PLATING
 HEAT SINK CLIP: STAINLESS STEEL
- $\Delta 2$ PITCH BETWEEN PORTS OF ONE 1X3 CAGE ASSEMBLY.
- $\Delta 3$ SPACING BETWEEN CAGES ON THE SAME PC BOARD, TO BE SPECIFIED BY CUSTOMER, MUST COMPLY WITH MINIMUM DIMENSIONS SHOWN.
- $\Delta 4$ REFERENCE APPLICATION SPEC 114-13218 FOR RECOMMENDED DRILL HOLE DIAMETER AND PLATING THICKNESS.
- $\Delta 5$ DATUMS AND BASIC DIMENSIONS ESTABLISHED BY CUSTOMER.
- $\Delta 6$ DIMENSION C IS THE NOMINAL THICKNESS OF CUSTOMER SUPPLIED PC BOARD.
 MINIMUM SINGLE SIDED PC BOARD THICKNESS: 1.45mm
 MINIMUM DOUBLE SIDED PC BOARD THICKNESS: 2.2mm PER QSFP
- $\Delta 7$ HEAT SINKS AND CLIPS SHIPPED ASSEMBLED TO CAGE ASSEMBLY. CAGE ASSEMBLY MAY BE PRESSED INTO THE PCB AS SHIPPED.
- $\Delta 8$ DATUM -A- IS TOP SURFACE OF PC BOARD.
- $\Delta 9$ DIMENSION APPLIES WITH MODULE INSERTED IN CAGE.
- $\Delta 10$ UNPLATED THRU HOLE.

- $\Delta 3$ BASELINE FOR THESE DIMENSIONS IS THE CENTER OF COMPLIANT PIN HOLE.
- $\Delta 4$ 2D BARCODE AND DATE CODE (YYWW) MARKED ON SIDE OF CAGE.
- $\Delta 5$ REFERENCE APP SPEC 114-13218 FOR GASKET THICKNESS CALCULATION.
- $\Delta 6$ FINISH:
 EMI SPRINGS: 2 μ m MINIMUM TIN
 FRONT FLANGE: 3 μ m MINIMUM TIN OVER 1.27 μ m MINIMUM NICKEL OVER 5.08 μ m MINIMUM COPPER
- $\Delta 7$ FINISH:
 HEAT SINK: ANODIZED BLACK.

- 11. MATES WITH QSFP MSA COMPATIBLE TRANSCEIVER.
- $\Delta 12$ SURFACE TRACES PERMITTED WITHIN THIS AREA EXCEPT WHERE CAGE STANDOFFS, SHOWN IN DETAIL S, CONTACT PC BOARD.

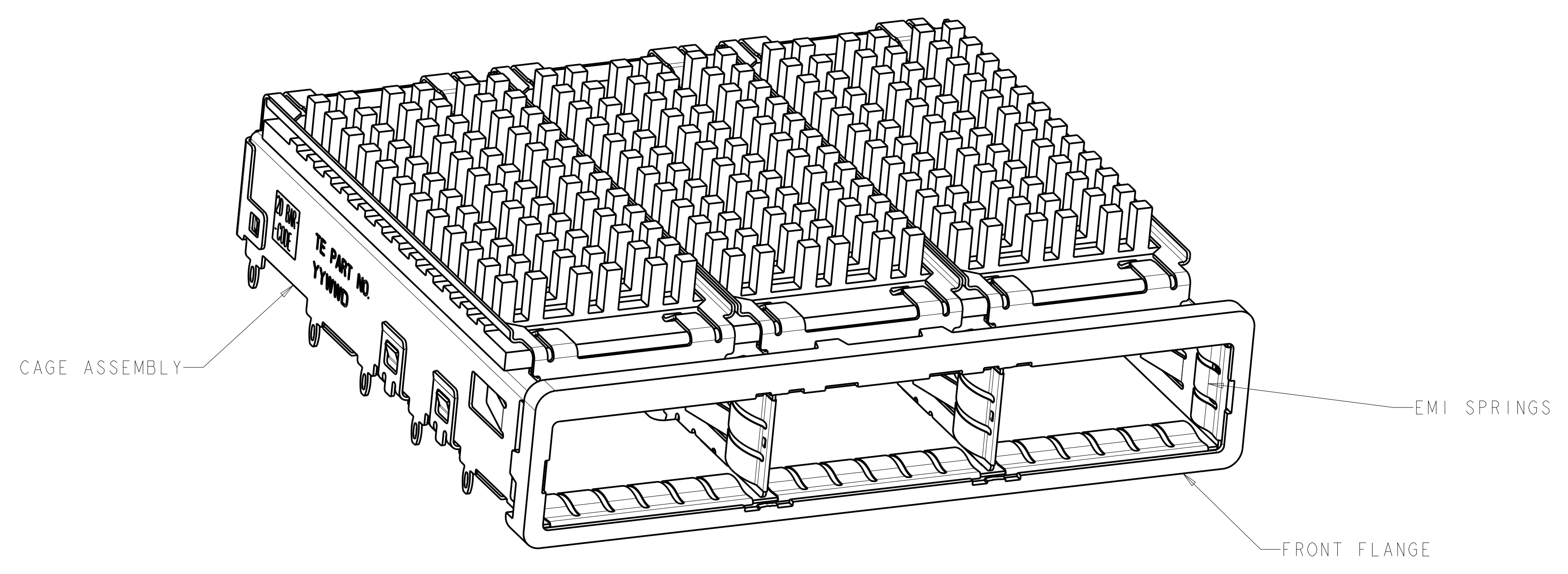
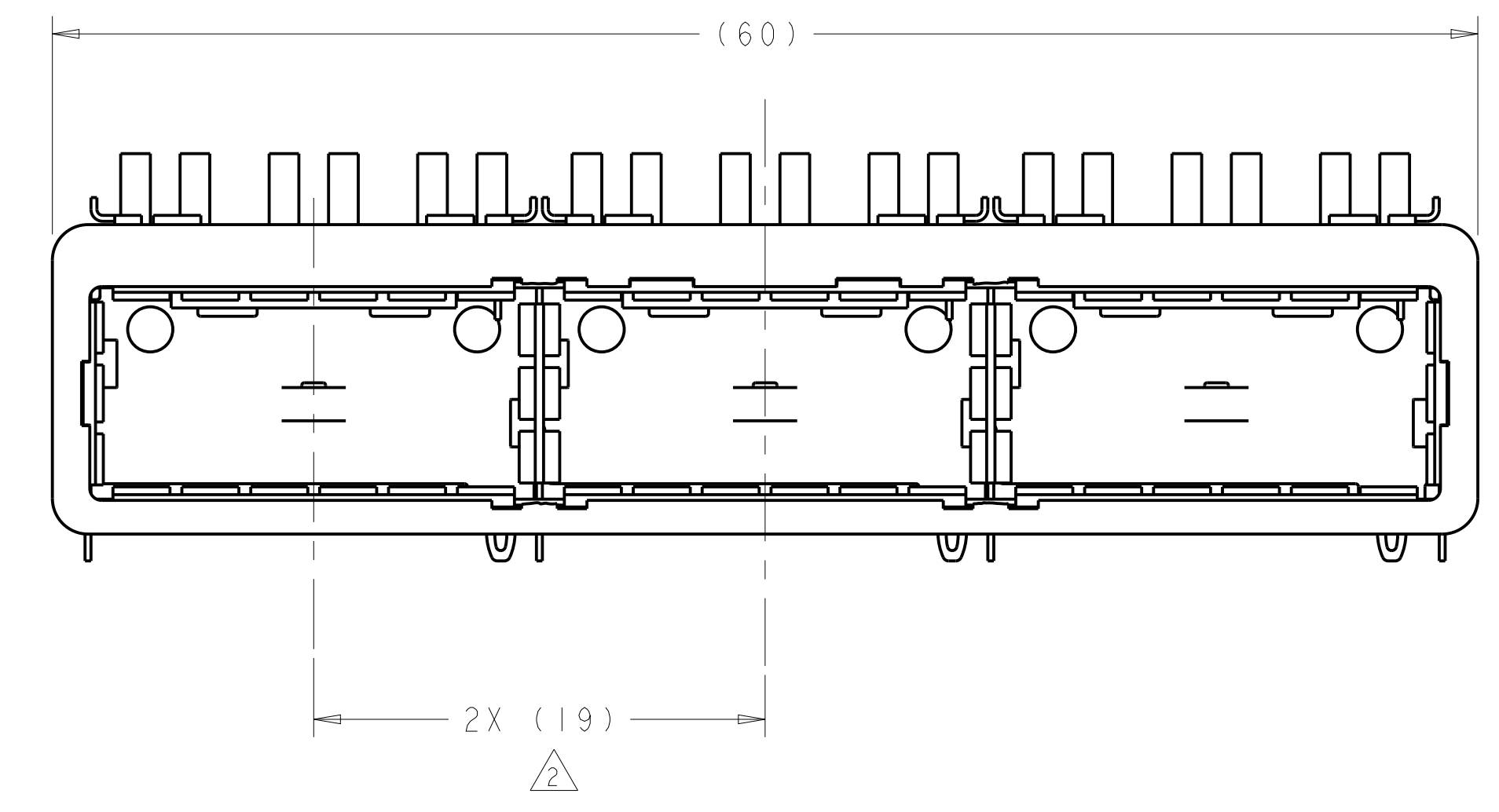
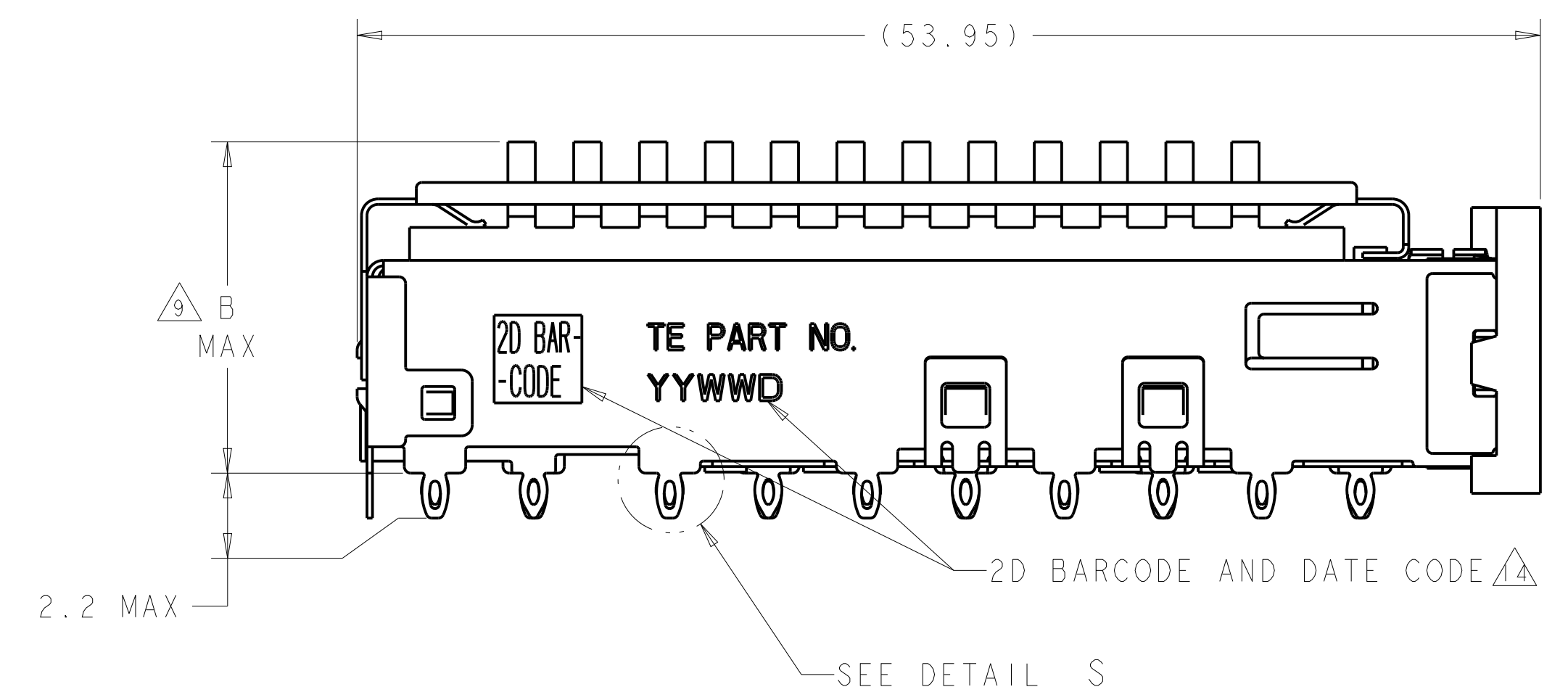

$\Delta 1$	16.8	CUSTOMERIZED	2007456-4
	23.0	NETWORKING	2007456-3
	16.0	SAN	2007456-2
	13.7	PCI	2007456-1
B		HEAT SINK PROFILE	PART NUMBER

THIS DRAWING IS A CONTROLLED DOCUMENT.		OWN: C. VALENTINE 07NOV2007	TE Connectivity NAME: 1X3 CAGE ASSEMBLY, BEHIND BEZEL, W/ HEAT SINKS, QSFP
DIMENSIONS: mm		CHK: E. BRIGHT 07NOV2007	
TOLERANCES UNLESS OTHERWISE SPECIFIED:		APVD: F. BRIGHT 07NOV2007	
0 PLC \pm 1 PLC ± 0.1 2 PLC ± 0.1 3 PLC \pm 4 PLC \pm ANGLES \pm		PRODUCT SPEC: 108-2286 APPLICATION SPEC: 114-13218 WEIGHT:	
MATERIAL: $\Delta 1$	FINISH: $\Delta 6$	RESTRICTED TO: A100779C=2007456	SCALE: 4:1 SHEET 1 OF 5 REV: F1

LOC		DIST		REVISIONS			
GP	00	P	LTN	DESCRIPTION	DATE	DWN	APVD
		-		SEE SHEET 1	-	-	-

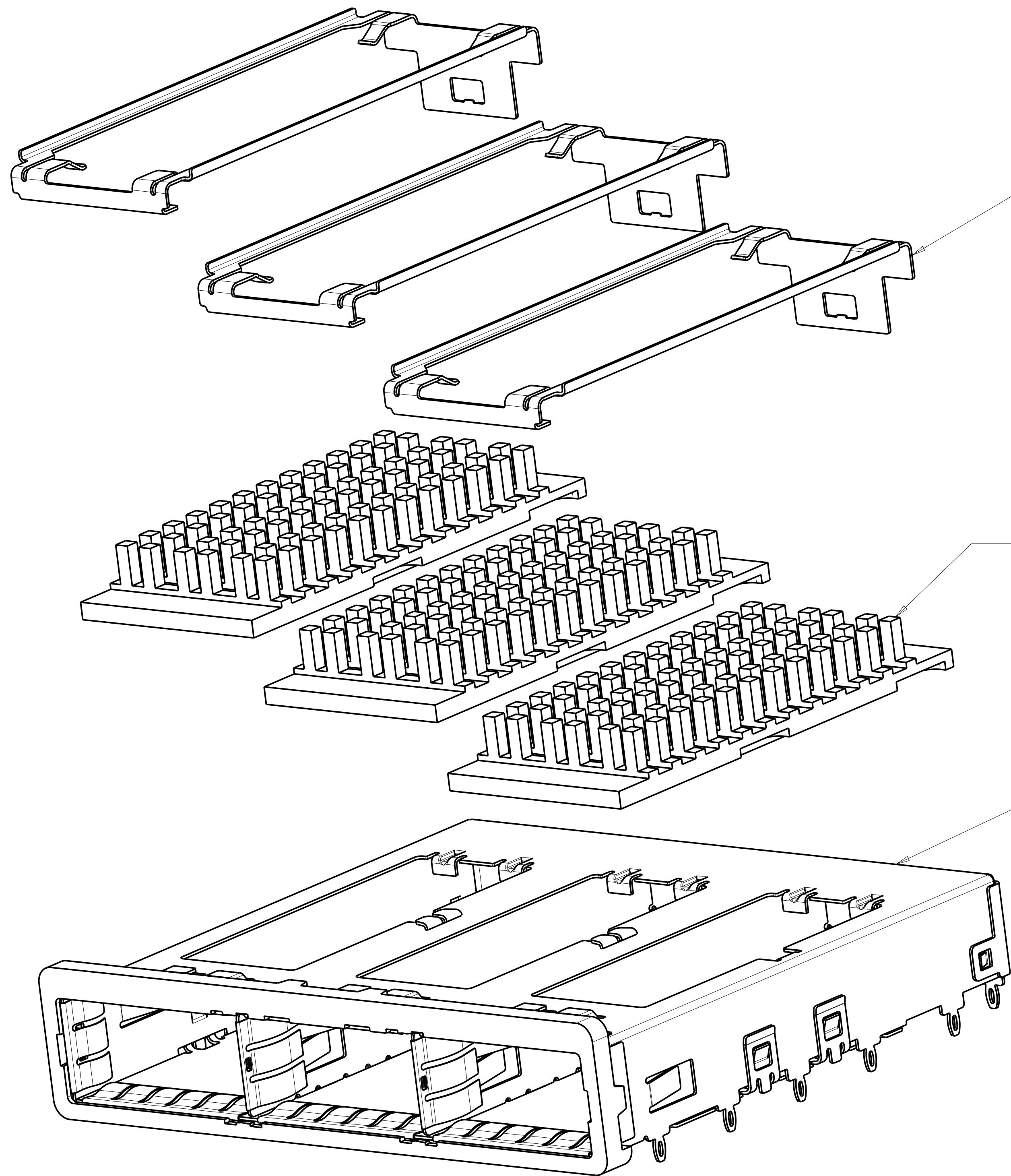

HEAT SINK CLIP Δ
 QUANTITY: 3

72 PIN HEAT SINK Δ
 QUANTITY: 3

1X3 BEHIND BEZEL QSFP
 CAGE ASSEMBLY
 QUANTITY: 1

THIS DRAWING IS A CONTROLLED DOCUMENT.		DWN C. VALENTINE 07NOV2007	
DIMENSIONS:		CHK E. BRIGHT 07NOV2007	
mm	TOLERANCES UNLESS OTHERWISE SPECIFIED:	APVD E. BRIGHT 07NOV2007	NAME 1X3 CAGE ASSEMBLY, BEHIND BEZEL, W/ HEAT SINKS, QSFP
0 PLC ±	1 PLC ±0.1	PRODUCT SPEC	
2 PLC ±0.1	3 PLC ±	108-2286	SIZE CAGE CODE DRAWING NO RESTRICTED TO
4 PLC ±	ANGLES ±	APPLICATION SPEC	
MATERIAL	FINISH	114-13218	A100779C=2007456
		WEIGHT	CUSTOMER DRAWING
		SCALE 4:1	SHEET 2 OF 5

LOC	DIST	REVISIONS			
GP	00	REV	DATE	BY	APPV
-	-	SEE SHEET 1	-	-	-

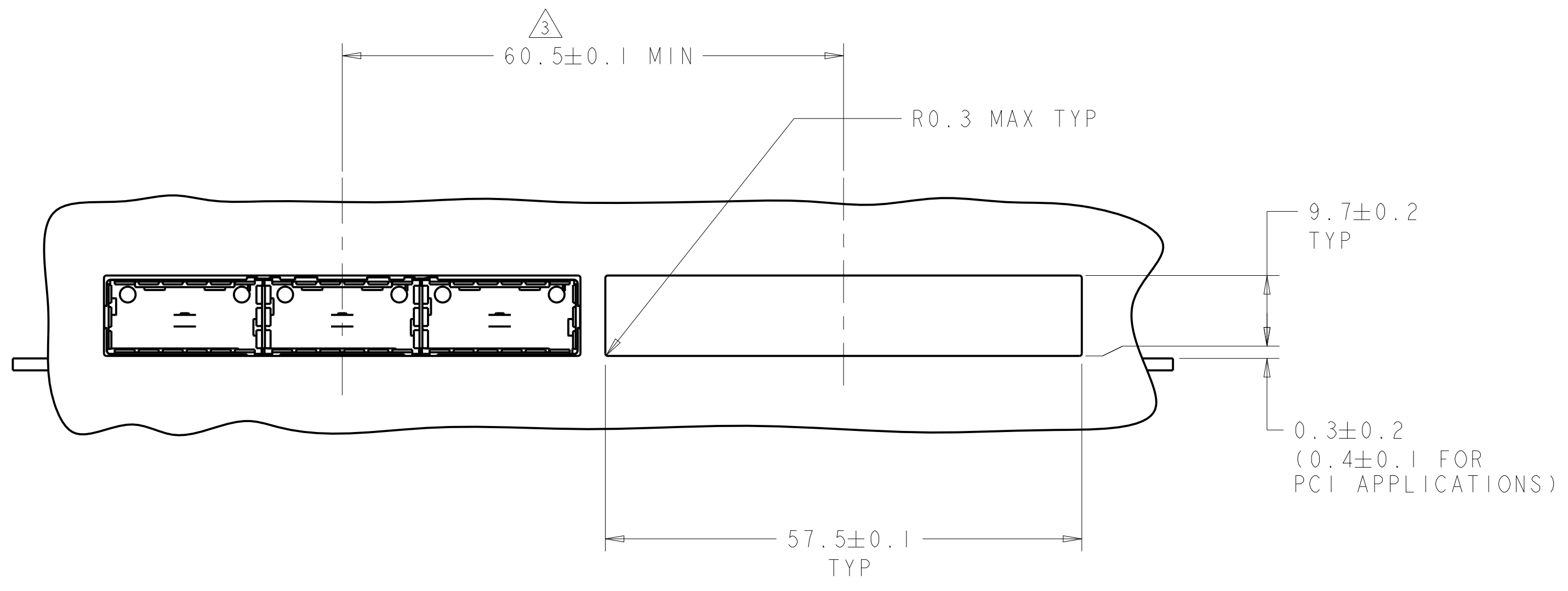

ONE SIDED CONFIGURATION
 SCALE 2:1

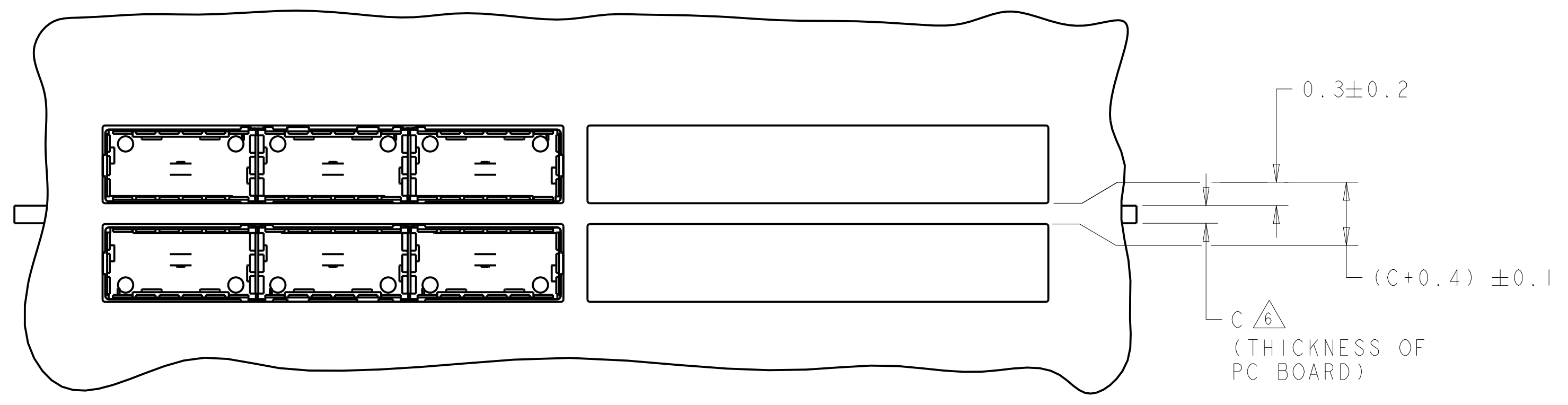
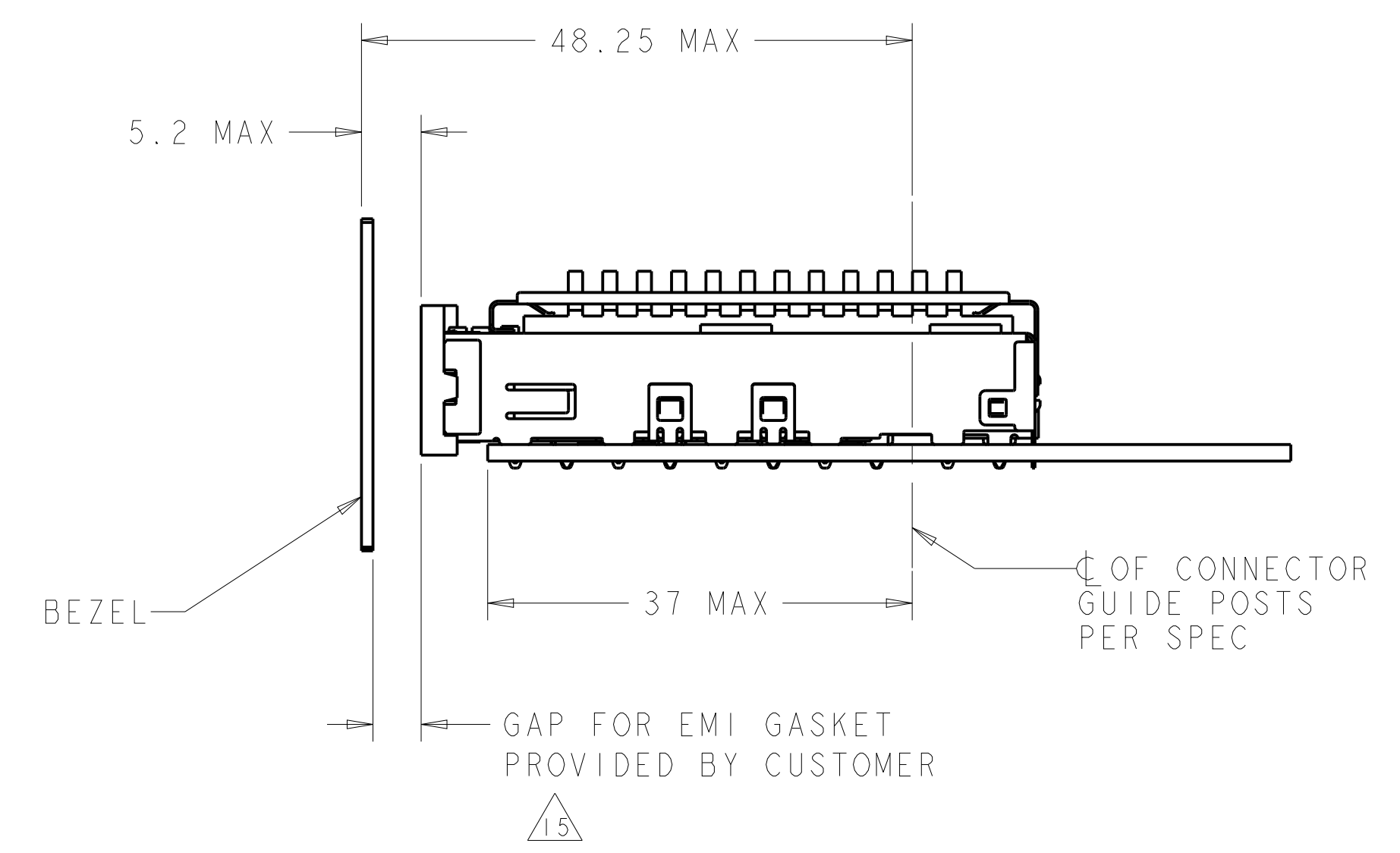

BELLY TO BELLY CONFIGURATION SIMILAR TO ONE SIDED EXCEPT WHERE NOTED
 SCALE 2:1

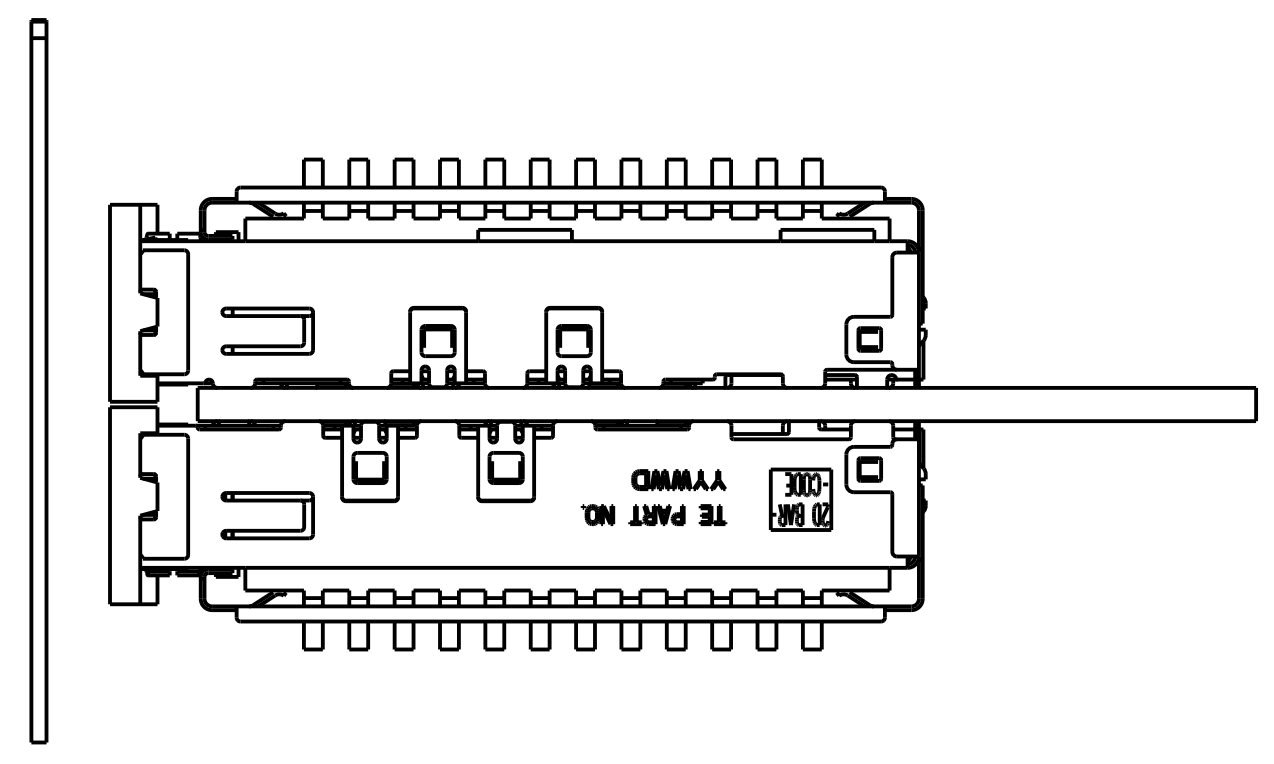

THIS DRAWING IS A CONTROLLED DOCUMENT.		OWN C. VALENTINE CHK E. BRIGHT APVD E. BRIGHT	07NOV2007 07NOV2007 07NOV2007	TE Connectivity NAME 1X3 CAGE ASSEMBLY, BEHIND BEZEL, W/ HEAT SINKS, QSFP
DIMENSIONS:	TOLERANCES UNLESS OTHERWISE SPECIFIED:	PRODUCT SPEC	APPLICATION SPEC	
mm	0 PLC ± 1 PLC ±0.1 2 PLC ±0.1 3 PLC ± 4 PLC ±	108-2286	114-13218	SIZE A100779
MATERIAL	FINISH	WEIGHT	CUSTOMER DRAWING	SCALE 4:1 SHEET 3 OF 5 REV F1

LOC	DIST	REV	DATE	BY	APPV
GP	00				
REVISIONS					

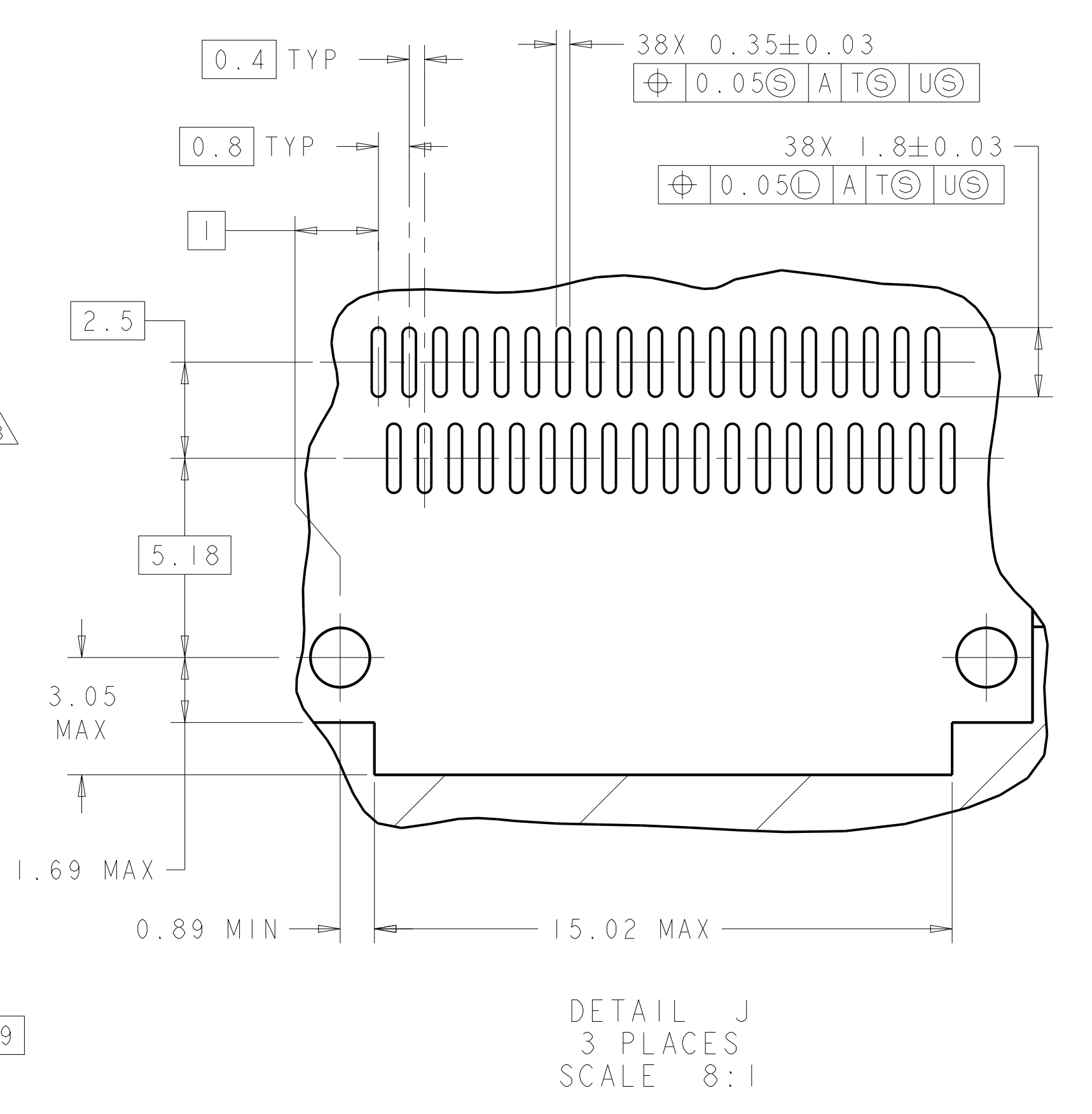
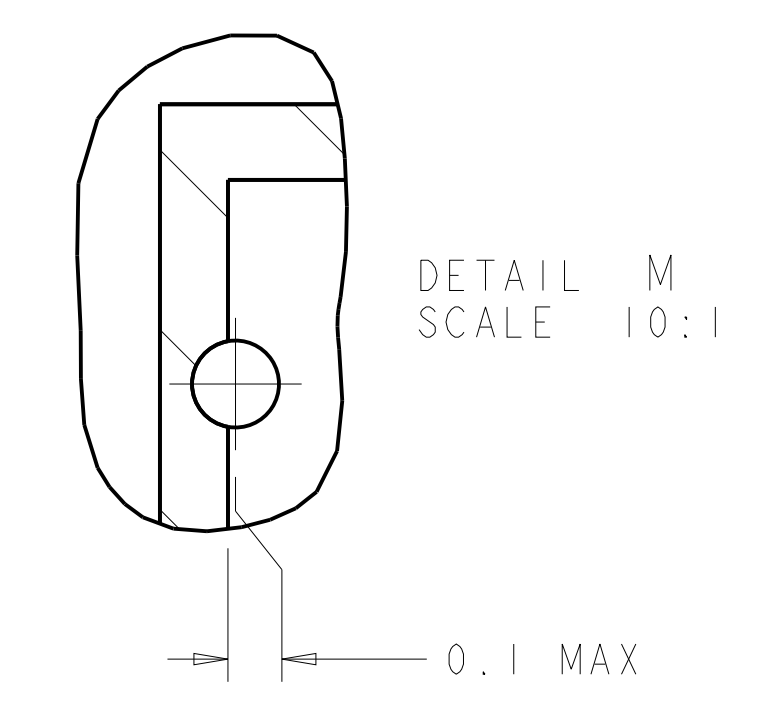
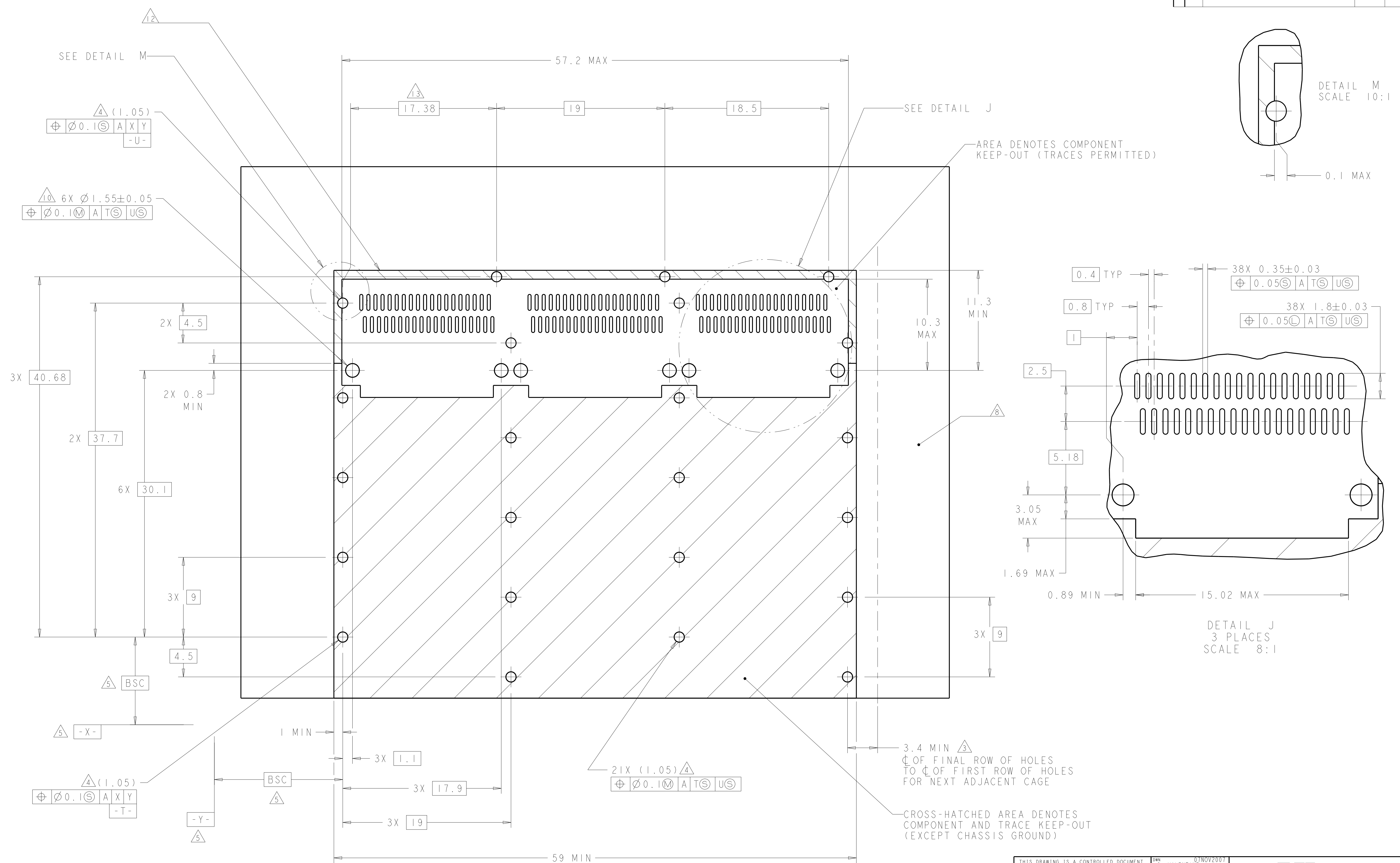

THIS DRAWING IS A CONTROLLED DOCUMENT.		DWN C. VALENTINE 07NOV2007	TE Connectivity
DIMENSIONS: mm		CHK E. BRIGHT 07NOV2007	
TOLERANCES UNLESS OTHERWISE SPECIFIED:		APVD E. BRIGHT 07NOV2007	NAME 1X3 CAGE ASSEMBLY, BEHIND BEZEL, W/ HEAT SINKS, QSFP
0 PLC ±	1 PLC ±0.1	PRODUCT SPEC	108-2286
2 PLC ±0.1	3 PLC ±	APPLICATION SPEC	114-13218
4 PLC ±	ANGLES ±	WEIGHT	A100779C=2007456
MATERIAL	FINISH	CUSTOMER DRAWING	SCALE 4:1 SHEET 4 OF 5 REV F1

LOC	DIST	REV	DATE	BY	APPV
GP	00				

REVISIONS					
REV	DATE	BY	APPV	DESCRIPTION	DATE
-	-	-	-	SEE SHEET 1	-

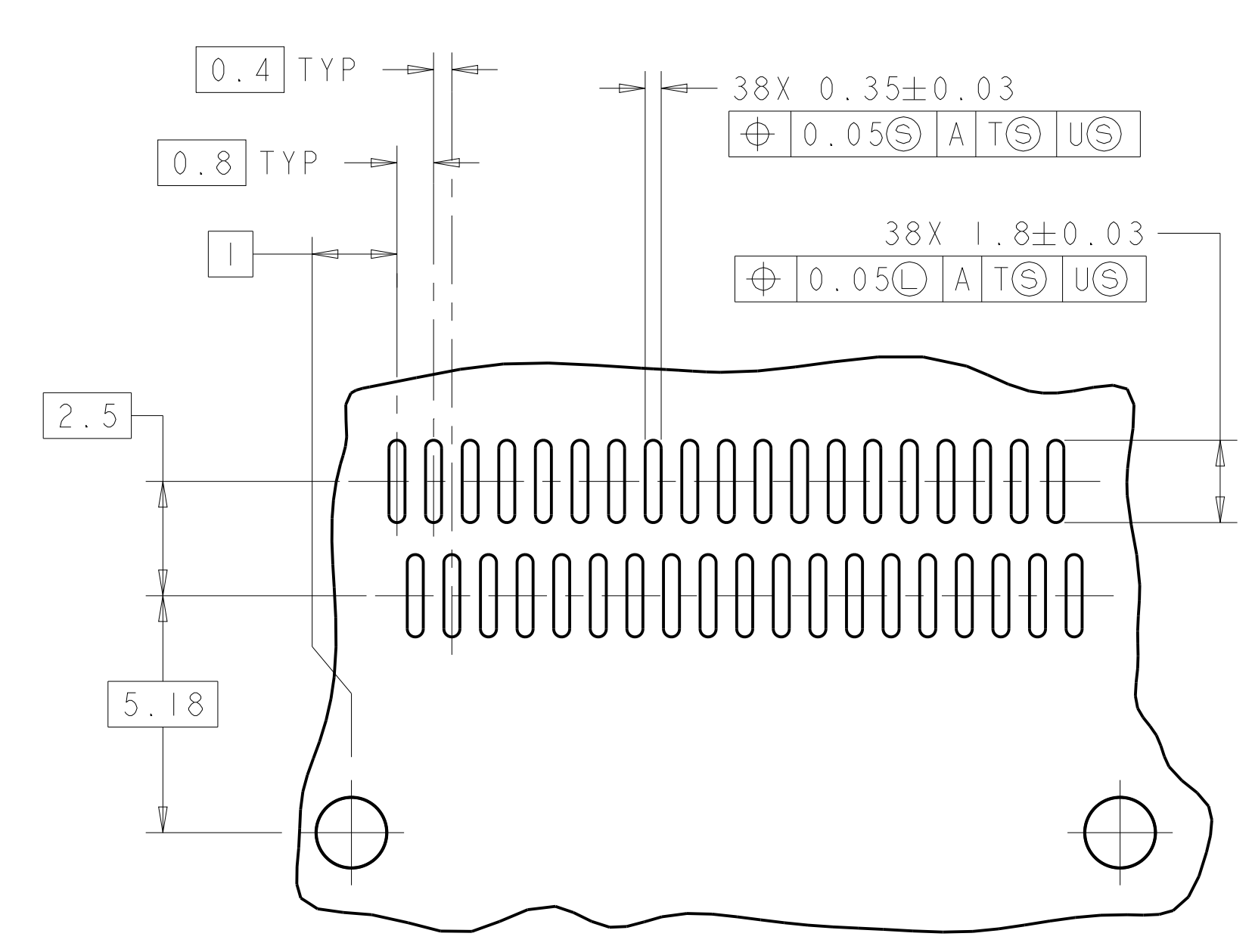
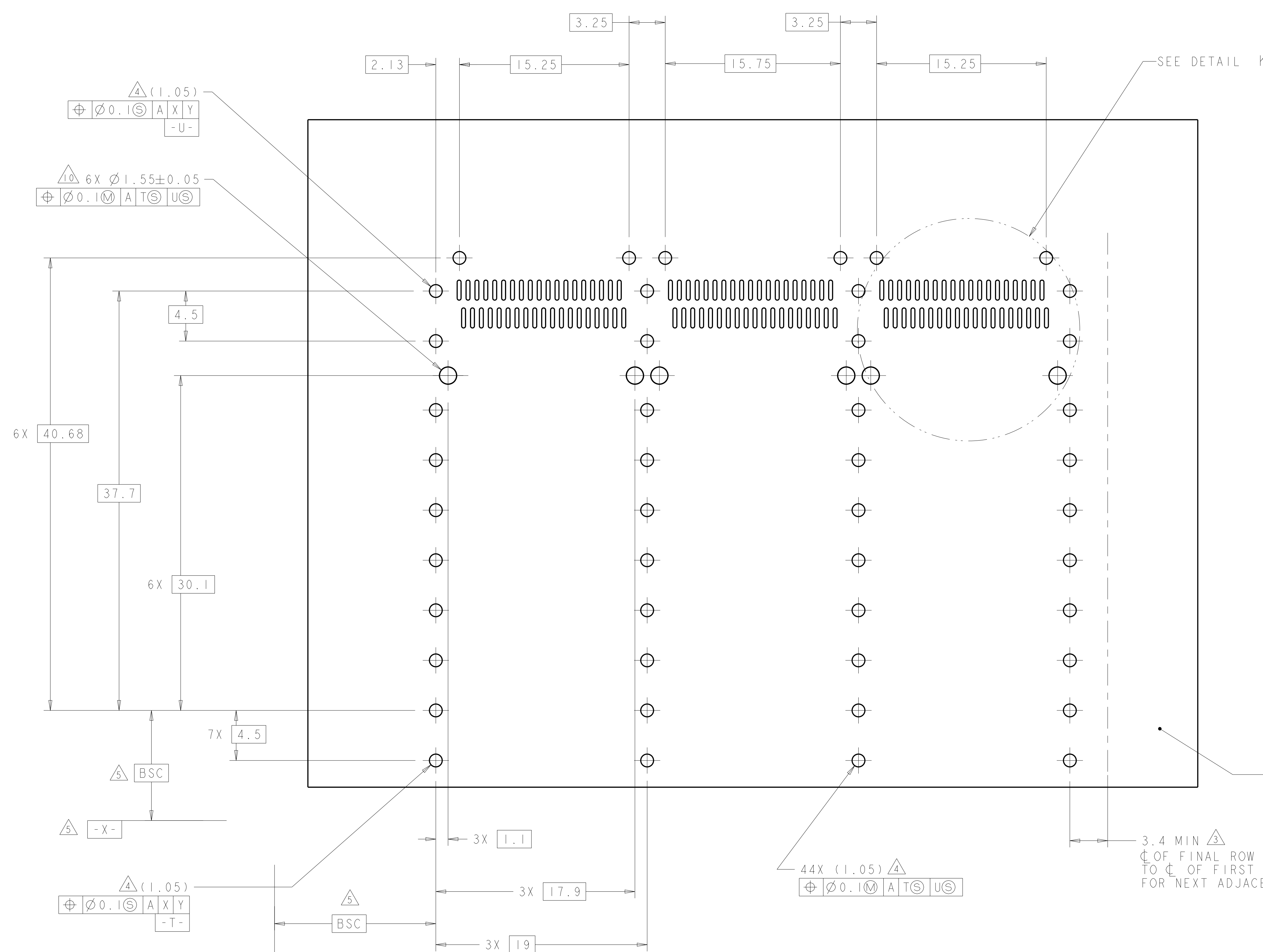

DETAIL K
 3 PLACES
 SCALE 8:1

RECOMMENDED PC BOARD LAYOUT
 BELLY TO BELLY CONFIGURATION
 SEE SHEET 4 FOR COMPONENT
 AND TRACE KEEP-OUTS
 SCALE 5:1

THIS DRAWING IS A CONTROLLED DOCUMENT.		OWN C. VALENTINE 07NOV2007	TE Connectivity										
DIMENSIONS: mm		CHK E. BRIGHT 07NOV2007											
TOLERANCES UNLESS OTHERWISE SPECIFIED:		APVD E. BRIGHT 07NOV2007	NAME 1X3 CAGE ASSEMBLY, BEHIND BEZEL, W/ HEAT SINKS, QSFP										
<table border="1"> <tr><td>0 PLC</td><td>±</td></tr> <tr><td>2 PLC</td><td>±0.1</td></tr> <tr><td>3 PLC</td><td>±0.1</td></tr> <tr><td>4 PLC</td><td>±</td></tr> <tr><td>ANGLES</td><td>±</td></tr> </table>		0 PLC	±	2 PLC	±0.1	3 PLC	±0.1	4 PLC	±	ANGLES	±	PRODUCT SPEC 108-2286	SIZE A100779
0 PLC	±												
2 PLC	±0.1												
3 PLC	±0.1												
4 PLC	±												
ANGLES	±												
MATERIAL		APPLICATION SPEC 114-13218	RESTRICTED TO										
FINISH		WEIGHT	SCALE 4:1 SHEET 5 OF 5 REV F1										
		CUSTOMER DRAWING											