

1. THIS RCPT. WILL MATE WITH ANY SIZE 6, 104 POSN. PLUG IN AMPLIMITE SERIES.
2. CONNECTOR SUPPLIED WITHOUT CONTACTS; SHOWN FOR ILLUSTRATION ONLY.
3. BE-CU RETENTION CLIPS ARE INCLUDED IN INSERT AND INSTALLED WITH TINES POINTING TOWARDS MATING FACE.
4. OVERALL DIMENSIONS DO NOT INCLUDE RAISED CAVITY IDENTIFICATION.
5. MARKING FAR SIDE REFERS TO WIDE SIDE OF KEYSTONE. NEAR SIDE REFERS TO NARROW SIDE OF KEYSTONE.
6. 100% INSPECTION REQUIRED PER BOEING 1B01:
  - A. VISUAL
  - B. DWV
  - C. IR
7. CUSTOMER REQUIRES SINGLE LOT DATE CODE.
8. SPECIAL REQUIREMENTS:
  - A. TEST TWO CONNECTORS PER LOT FOR COMPLIANCE TO GROMMET PEEL STRENGTH REQUIREMENTS.
  - B. TEST ALL CIRCUIT CAVITIES FOR MISALIGNMENT OR EXCESSIVE ADHESIVE.

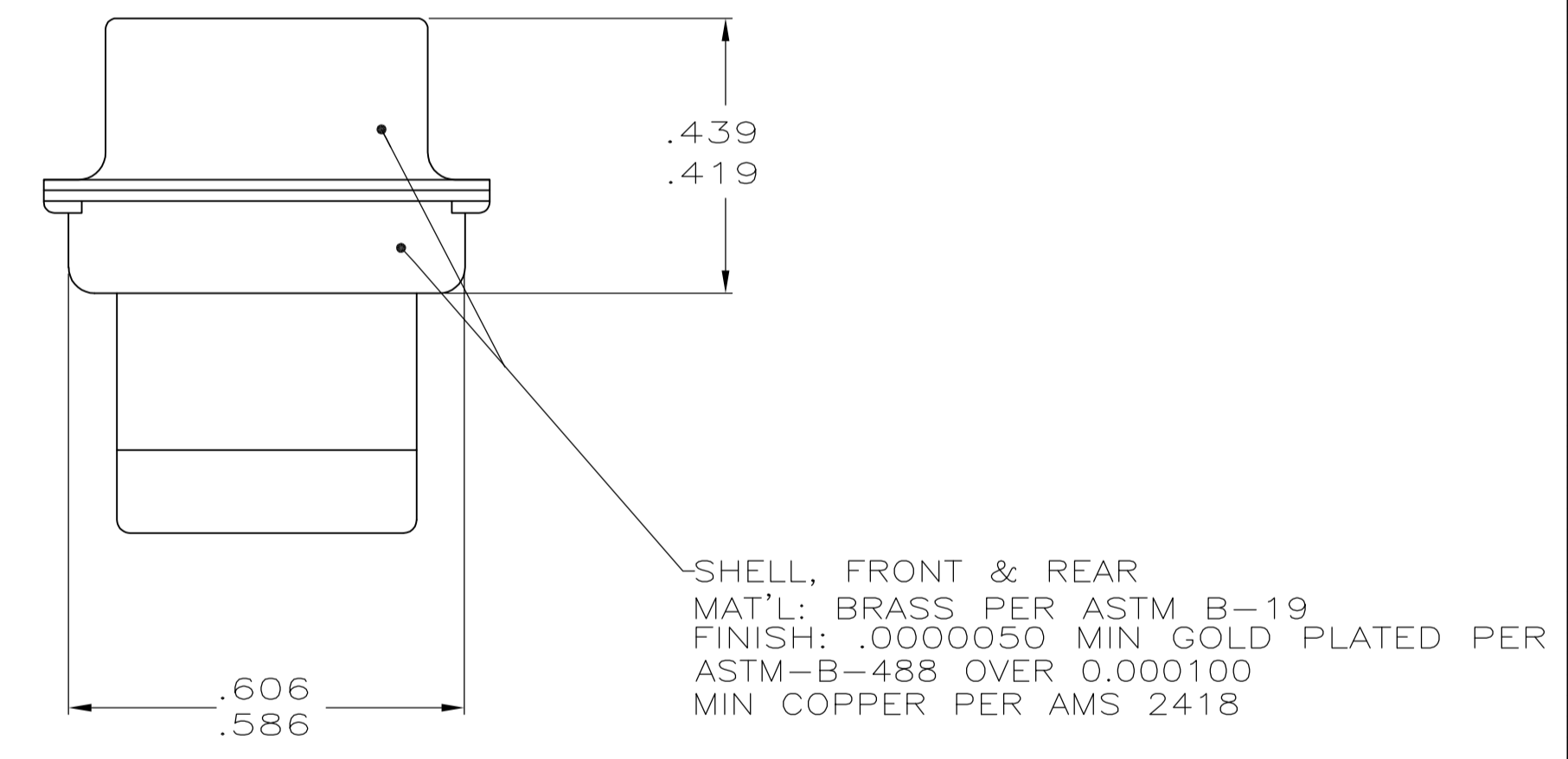
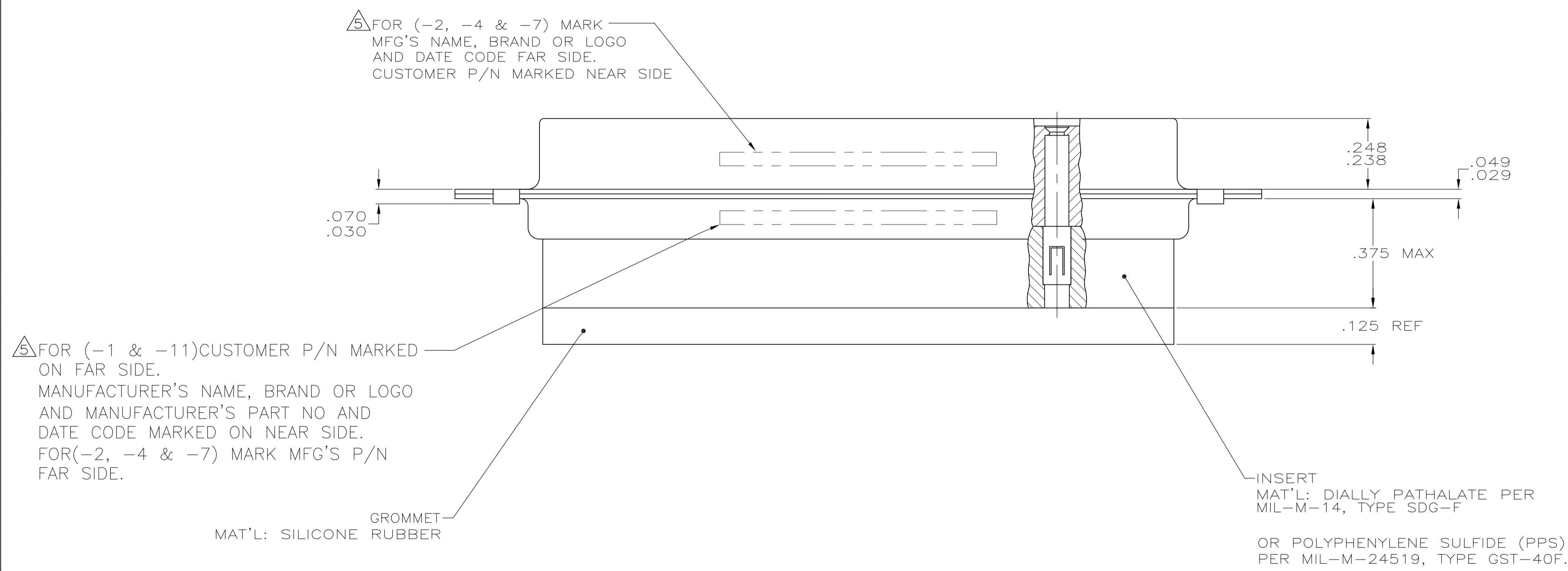

1B01-030RHW	1-211672-1
-	211672-7
-	211672-4
2A065-024V-001	211672-2
1B01-030	211672-1
REMARKS	CUSTOMER PART NO. PART NO.

THIS DRAWING IS A CONTROLLED DOCUMENT.		BIN J. KAISER 3-11-04		TE Connectivity	
DIMENSIONS: INCHES		CIRK 3-25-04			
TOLERANCES UNLESS OTHERWISE SPECIFIED:		L OH 3-25-04		NAME	
0 PLC ± -		APVD L OH 3-25-04		RCPT. ASSY, AMPLIMITE, 104 POSN., SIZE 6, SERIES 90, NON-MAGNETIC, SPECIAL WITH GROMMET	
1 PLC ± -		PRODUCT SPEC		APPLICATION SPEC	
2 PLC ± -		SIZE		A1 00779 C=211672	
3 PLC ± .005		WEIGHT		CUSTOMER DRAWING	
4 PLC ± -		SCALE		4:1	
ANGLES ± 1°		SHEET		1 OF 1	
MATERIAL SEE CALLOUTS		FINISH SEE CALLOUTS		REV	