

PART NUMBER	REVISION	DESCRIPTION	FEED TYPE
2150375-1	C	FINE CRIMP HEIGHT ADJUST	MECHANICAL
2150375-2	D	FINE CRIMP HEIGHT ADJUST	PNEUMATIC
7-2150375-1	C	MECHANICAL AND CRIMP TOOLING KIT	MECHANICAL
7-2150375-2	D	PNEUMATIC AND CRIMP TOOLING KIT	PNEUMATIC
7-2150375-7	A	CRIMP TOOLING KIT	-

ATLANTIC VERSION TERMINATOR INTERFACE ADAPTER



APPLICATOR DATA		
CRIMP	SIZE	TYPE
WIRE	2.79 mm [.110]	F
INSUL	4.83 mm [.190]	F
APPLICATOR INSTRUCTIONS 408-35043		

TERMINAL DATA: TE TERMINAL TE CRIMP SPECIFICATION			
TERMINAL NAME: RING, TONGUE			
WIRE STRIP LENGTH		INSULATION DIAMETER RANGE	
.173-.203 IN [4.39-5.16 mm]		∅.105-.170 IN [2.67-4.32 mm]	
TERMINAL APPLICATION SPECIFICATION	114-2084		
TERMINALS APPLIED			
TE TERMINAL	TE TERMINAL	TE TERMINAL	TE TERMINAL
109452-1	109452-2	109452-3	109452-4
109452-5	109452-6		

WIRE SIZE	CRIMP HEIGHT mm [INCH]	CRIMP HEIGHT REFERENCE SETTING
14 AWG	2.13+/-0.05 [.084+/-0.002]	5.6
16 AWG	1.96+/-0.05 [.077+/-0.002]	7.3
18 AWG	1.78+/-0.05 [.070+/-0.002]	9.4

- 1 RECOMMENDED SPARE PARTS
- 2 REFER TO SUPPLIED INSTRUCTION SHEET FOR CLEANING, LUBRICATION AND STORAGE OF APPLICATOR.
- 3 APPLY PART NUMBER 2-23419-6 LOCTITE TO THREADS OF ITEM 242.
- 4 CRIMP HEIGHT REFERENCE SETTING WAS THE SETTING USED WHEN THE APPLICATOR WAS QUALIFIED AT THE FACTORY. ADJUSTMENT MAY BE NECESSARY WHEN RUNNING APPLICATOR IN THE FIELD.
- 5. UNLESS SPECIFIED OTHERWISE TORQUE VALUES SHALL BE USED PER DOCUMENT, 101-35000.

***WARNING**
ON INSTALLATION, SET WIRE DISC TO CRIMP HEIGHT REFERENCE SETTING FOR LARGEST WIRE SIZE. CRIMP HEIGHT REFERENCE SETTINGS GREATER THAN THE VALUE SHOWN MAY CAUSE DAMAGE TO THE CRIMP TOOLING, REFER TO THE INSTRUCTION SHEET FOR PROPER SETUP AND ADJUSTMENTS.

LOC	DIST	REVISIONS					
A	66	P	LTN	DESCRIPTION	DATE	DWN	APVD
		A		RELEASED	13NOV2013	LG	TE
		B		ECR-18-015880	08OCT2018	FL	TE
		C		ECR-18-016221	12OCT2018	FL	TE
		D		ECR-20-014688	16OCT2020	TB	RK

-	1	-	1	-	2119641-1	FEED CAM, AIR FEED	248	
-	1	1	1	1	2119082-9	CAM, SNAIL, INSULATION ADJUSTMENT	244	
-	1	1	1	1	2079764-1	WASHER, WAVE SPRING, CREST-TO-CREST	243	
-	1	1	1	1	2119083-1	RETAINER, INSULATION DIAL	242	
-	-	1	-	1	2119580-1	MECHANICAL FEED ASSEMBLY	239	
-	1	-	1	-	2844940-3	AIR FEED MODULE	238	
-	1	1	1	1	1-18028-0	WASHER, FLAT, REG M8	192	
-	REF	REF	REF	REF	994970-2	COUNTER, MAGNETIC	164	
-	1	1	1	1	455888-6	SPACER, CRIMPER	82	
-	1	1	1	1	1803607-4	DOCUMENTATION PACKAGE	71	
-	2	2	2	2	2-18032-2	SCR, SET, FLT PNT, M3 X 10.0	70	
-	1	1	1	1	2119740-1	TAG, IDENTIFICATION	67	
-	2	2	2	2	2168078-1	SCREW, DRIVE, RH, RoHS, 2 x .188	66	
-	1	1	1	1	2168083-2	SCR, SKT HD CAP, RoHS, M4 X 8.0	60	
-	1	1	1	1	5-18022-5	SCR, HEX HD CAP, M4 X 6.0	59	
-	-	1	-	1	2063961-1	FEED FINGER	58	
-	4	4	4	4	2168400-4	SHCS, LOW HEAD, RoHS, M4 X 8	57	
-	2	2	2	2	2168083-2	SCR, SKT HD CAP, RoHS, M4 X 8.0	56	
-	2	2	2	2	5018030-1	NUT, HEX, REG, RoHS, M3	54	
-	2	2	2	2	986965-8	NUT, LOCK, HEX, TORQUE (M4)	53	
-	1	-	1	-	2063961-9	FEED FINGER	51	
-	1	2	1	2	18023-9	SCR, SKT HD CAP M4 X 6.0	49	
-	-	1	-	1	2119652-1	FEED CAM, PRE FEED	48	
-	-	1	-	1	2119653-1	FEED CAM, POST FEED	47	
-	1	1	1	1	2119655-5	APPLICATOR BASIC ASSEMBLY, EF	46	
-	1	1	1	1	1803517-1	RAM ASSEMBLY, EF ATLANTIC	44	
-	1	1	1	1	1803602-1	SCR, BHSC, RoHS (M8 X 25)	41	
-	8	8	8	8	1-18028-2	WASHER, FLAT, REG M4	33	
-	2	2	2	2	2168083-9	SCR, SKT HD CAP, RoHS, M4 X 20	31	
-	2	2	2	2	2168083-2	SCR, SKT HD CAP, RoHS, M4 X 8.0	29	
-	1	1	1	1	240639-1	STRIPPER (MACHINING)	27	
-	2	2	2	2	1-2168083-5	SCR, SKT HD CAP, RoHS, M4 X 30	25	
-	1	1	1	1	1752371-5	PLATE, STRIP GUIDE	24	
-	2	2	2	2	2-22281-3	SPRING, COMPRESSION	22	
-	1	1	1	1	1803292-4	DRAG	20	
-	1	1	1	1	1901696-3	STRIP GUIDE, REAR	19	
-	1	1	1	1	1901695-3	STRIP GUIDE, FRONT	18	
-	4	4	4	4	1-2079383-1	SCR, BHSC, RoHS (M6 X 12)	17	
-	1	1	1	1	3-240641-9	SPACER	16	
-	1	1	1	1	240644-1	PLATE, REAR SHEAR	11	
-	-	-	-	-	-	-	10	
-	1	1	1	1	690482-6	PLATE, FRONT SHEAR	9	
-	1	2	2	1	1	4-1333219-9	ANVIL, COMBINATION	8
-	1	1	1	1	2217206-4	BLADE, SLUG	7	
-	-	-	-	-	-	-	6	
-	1	1	1	1	240641-9	SPACER	5	
-	1	1	1	1	3-238011-5	BLOCK, CRIMPER SPACER	4	
-	1	2	2	1	1	1-1803016-2	CRIMPER, INSULATION F	3
-	1	1	1	1	455888-6	SPACER, CRIMPER	2	
-	1	2	2	1	1	2-456408-0	CRIMPER, WIRE PREMIUM	1
-	77	72	71	2	1	PART NO	DESCRIPTION	ITEM NO

ATLANTIC VERSION
Shown on sheets 1 of 4 & 2 of 4
(Pacific version shown on sheets 3 of 4 & 4 of 4)

DIMENSIONS:		TOLERANCES UNLESS OTHERWISE SPECIFIED:		DWN		15OCT2013	
mm		0 PLC ±		R. HUANG		15OCT2013	
		1 PLC ±		L. ZHANG		15OCT2013	
		3 PLC ±		APVD		15OCT2013	
		4 PLC ±		U. GUO		15OCT2013	
		ANGLES ±		PRODUCT SPEC			
		FINISH ±		APPLICATION SPEC			
MATERIAL		FINISH		WEIGHT		SIZE	
						A 00779 C=2150375	
Customer Accessible Production Drawing				SCALE		SHEET 1 OF 4	
				1:1		REV D	

LOC	DIST	REV	DESCRIPTION	DATE	OWN	APVD
A	66		SEE SHEET 1			

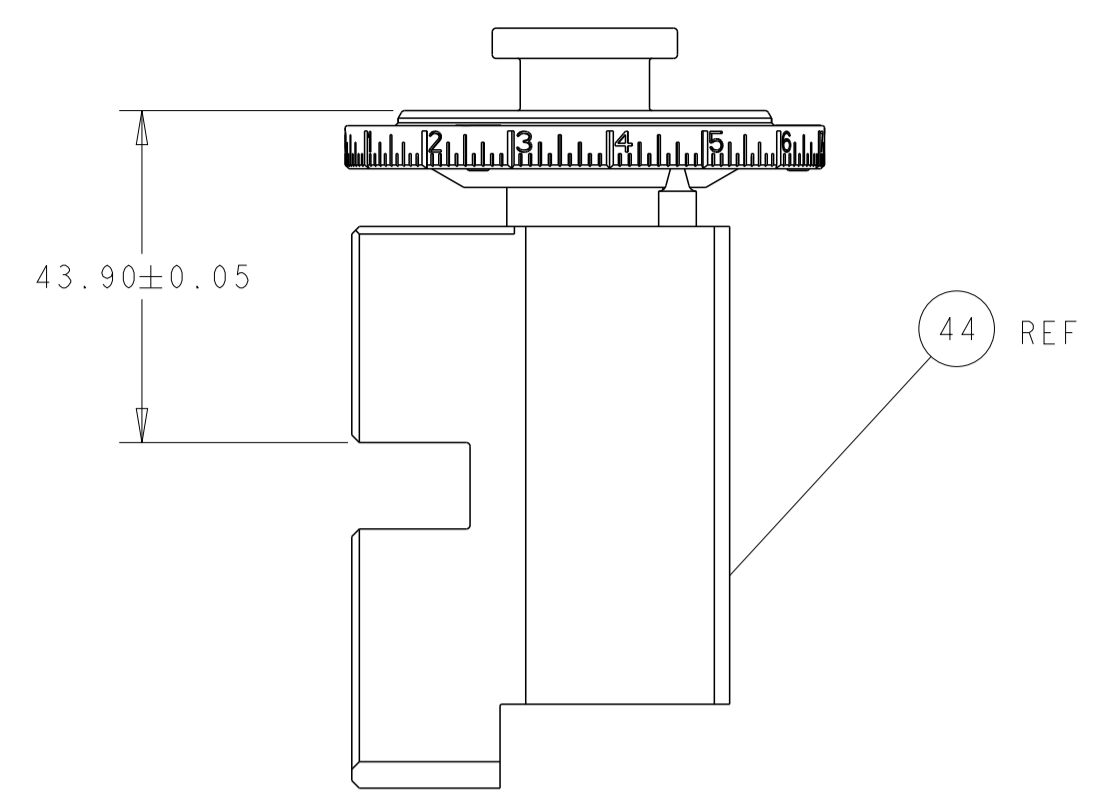

RAM SET-UP

FEED TYPE
MECHANICAL

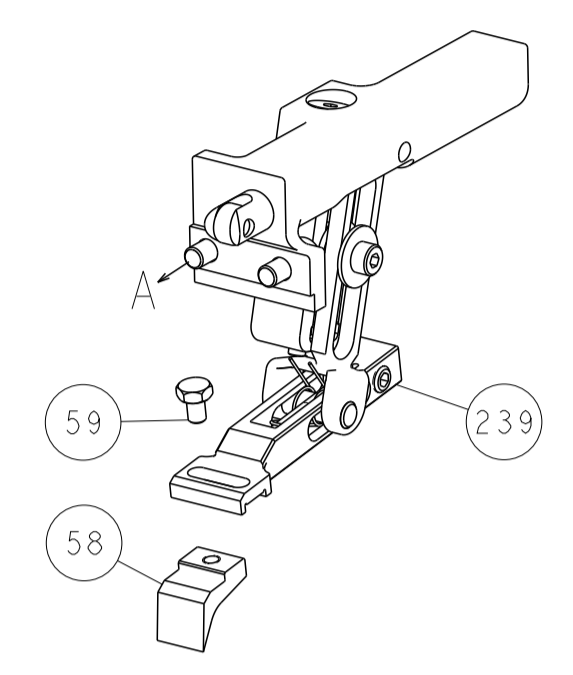

PNEUMATIC

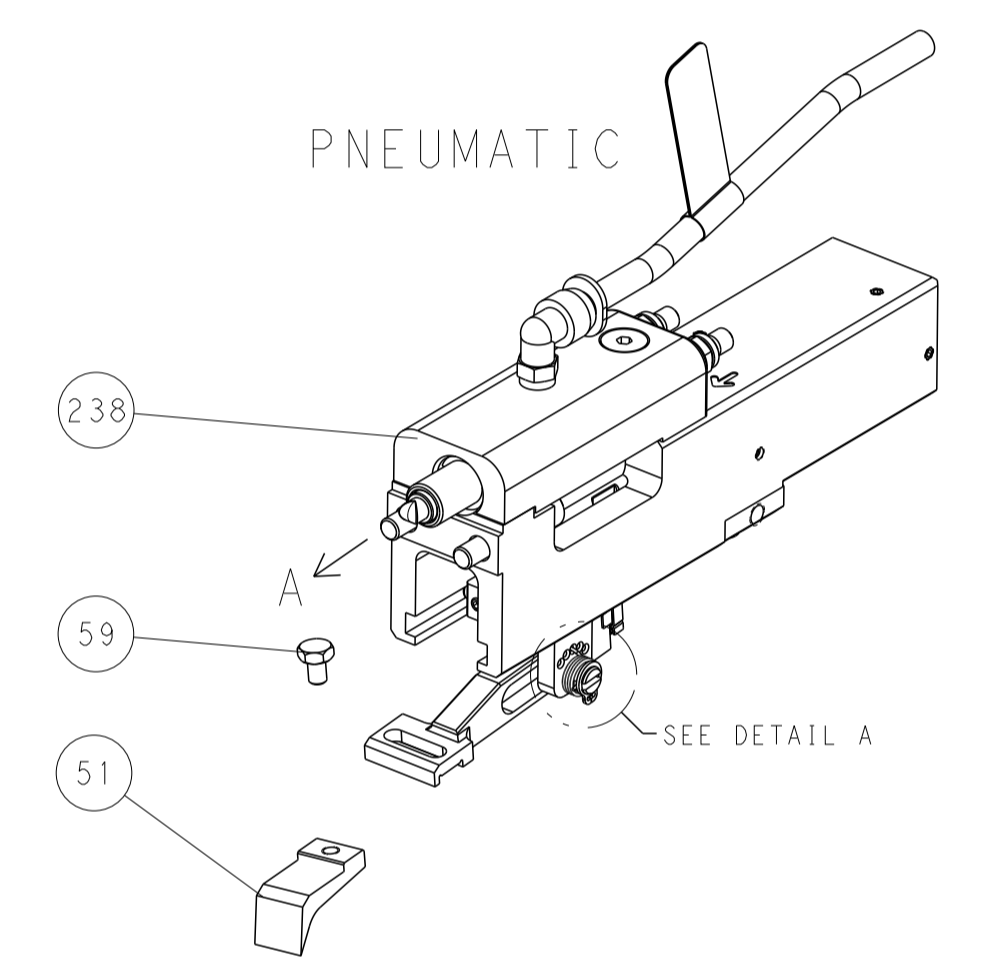

FEED SPRING
SETTING POSITION

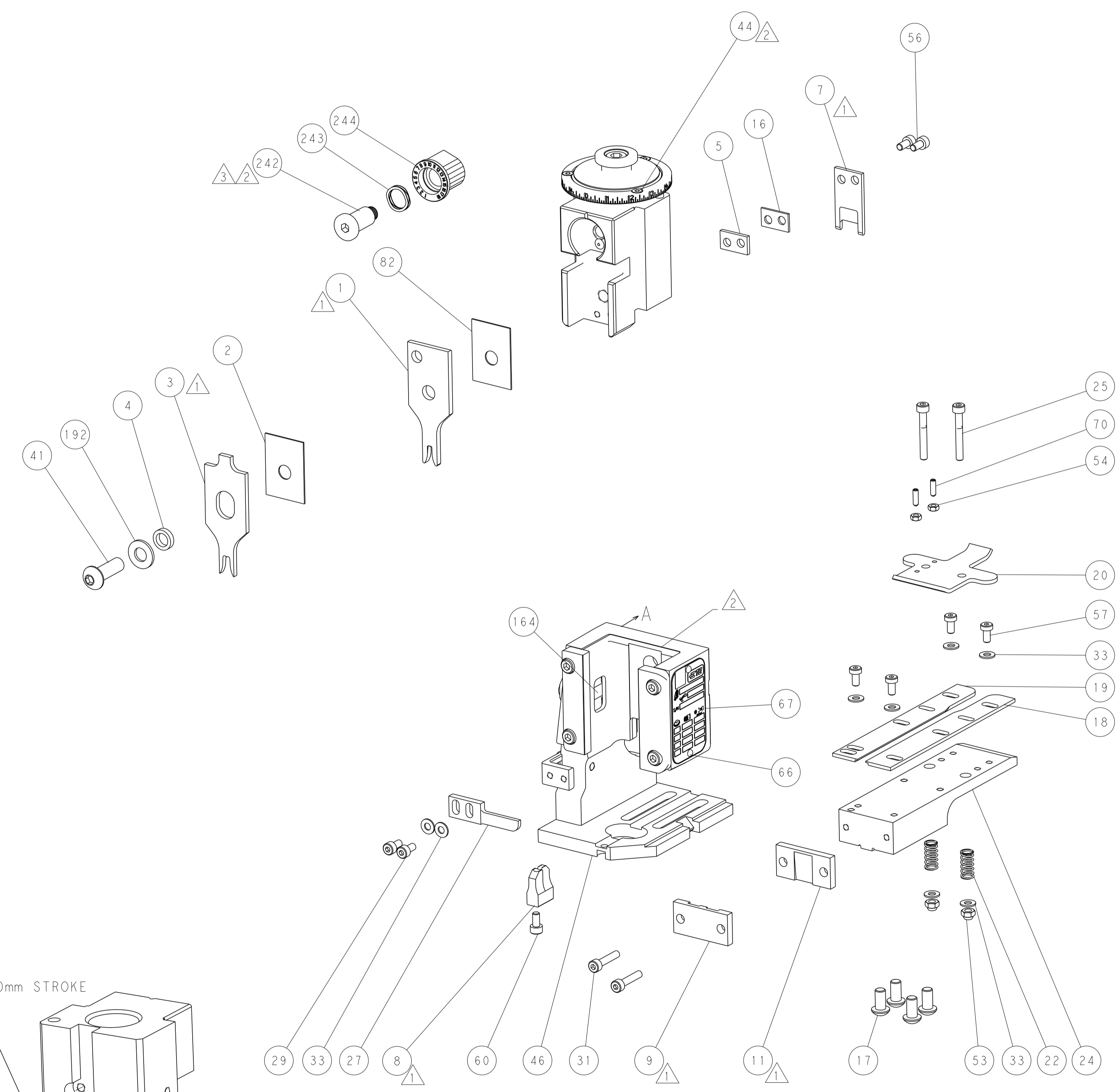
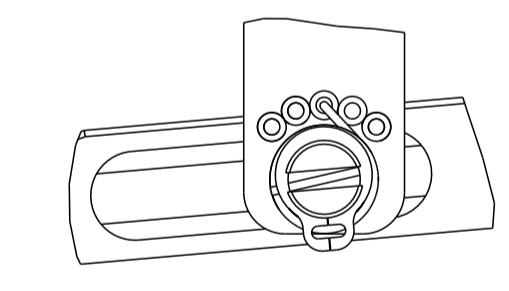

CAM POSITIONS

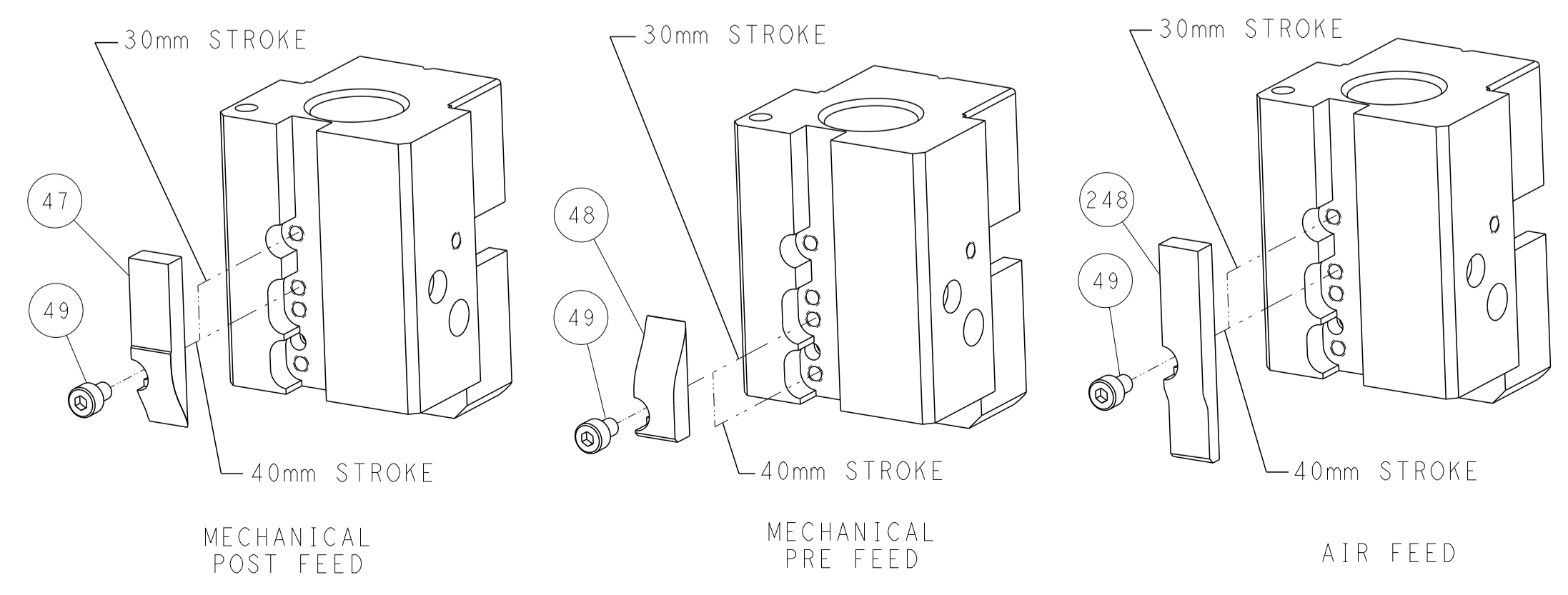

ATLANTIC VERSION
 Shown on sheets 1 of 4 & 2 of 4
 (Pacific version shown on sheets 3 of 4 & 4 of 4)

DIMENSIONS: mm 		TOLERANCES UNLESS OTHERWISE SPECIFIED: 0 PLC ± 1 PLC ± 2 PLC ± 3 PLC ± 4 PLC ± ANGLES ± FINISH		DWN K. HUANG 15OCT2013 CHK L. ZHANG 15OCT2013 APVD J. GUO 15OCT2013 PRODUCT SPEC APPLICATION SPEC WEIGHT Customer Accessible Production Drawing		NAME Ocean End Feed Applicator SIZE CAGE CODE DRAWING NO. A1 00779 ©=2150375 SCALE 1:1 SHEET 2 OF 4 REV D		RESTRICTED TO	
-----------------------	--	---	--	---	--	---	--	---------------	--

8	7	6	5	4	3	2	1
THIS DRAWING IS UNPUBLISHED.		RELEASED FOR PUBLICATION		20			
COPYRIGHT © BY TYCO ELECTRONICS CORPORATION. ALL RIGHTS RESERVED.							
PART NUMBER	REVISION	DESCRIPTION	FEED TYPE				
2-2150375-1	C	FINE CRIMP HEIGHT ADJUST	MECHANICAL				
2-2150375-2	D	FINE CRIMP HEIGHT ADJUST	PNEUMATIC				
7-2150375-7	A	CRIMP TOOLING KIT	-				

PACIFIC VERSION TERMINATOR
INTERFACE ADAPTER



LOC	DIST	REVISIONS					
A	66	P	LTN	DESCRIPTION	DATE	OWN	APVD
		-		SEE SHEET 1	-	-	-

APPLICATOR DATA		
CRIMP	SIZE	TYPE
WIRE	2.79 mm [.110]	F
INSUL	4.83 mm [.190]	F
APPLICATOR INSTRUCTIONS 408-35043		

TERMINAL DATA: TE TERMINAL		TE CRIMP SPECIFICATION	
TERMINAL NAME: RING, TONGUE			
WIRE STRIP LENGTH .173-.203 IN [4.39-5.16 mm]		INSULATION DIAMETER RANGE Ø.105-.170 IN [2.67-4.32 mm]	
TERMINAL APPLICATION SPECIFICATION	114-2084	-	-
TERMINALS APPLIED			
TE TERMINAL	TE TERMINAL	TE TERMINAL	TE TERMINAL
109452-1	109452-2	109452-3	109452-4
109452-5	109452-6		

WIRE SIZE	CRIMP HEIGHT mm [INCH]	CRIMP HEIGHT REFERENCE SETTING
14 AWG	2.13 +/- 0.05 [.084 +/- .002]	5.6
16 AWG	1.96 +/- 0.05 [.077 +/- .002]	7.3
18 AWG	1.78 +/- 0.05 [.070 +/- .002]	9.4

- RECOMMENDED SPARE PARTS
- REFER TO SUPPLIED INSTRUCTION SHEET FOR CLEANING, LUBRICATION AND STORAGE OF APPLICATOR.
- APPLY PART NUMBER 2-23419-6 LOCTITE TO THREADS OF ITEM 242.
- CRIMP HEIGHT REFERENCE SETTING WAS THE SETTING USED WHEN THE APPLICATOR WAS QUALIFIED AT THE FACTORY. ADJUSTMENT MAY BE NECESSARY WHEN RUNNING APPLICATOR IN THE FIELD.
- UNLESS SPECIFIED OTHERWISE TORQUE VALUES SHALL BE USED PER DOCUMENT, 101-35000.

***WARNING**
ON INSTALLATION, SET WIRE DISC TO CRIMP HEIGHT REFERENCE SETTING FOR LARGEST WIRE SIZE. CRIMP HEIGHT REFERENCE SETTINGS GREATER THAN THE VALUE SHOWN MAY CAUSE DAMAGE TO THE CRIMP TOOLING, REFER TO THE INSTRUCTION SHEET FOR PROPER SETUP AND ADJUSTMENTS.

-	1	1	2119082-9	CAM, SNAIL, INSULATION ADJUSTMENT	244
-	1	1	2079764-1	WASHER, WAVE SPRING, CREST-TO-CREST	243
-	1	1	2119083-1	RETAINER, INSULATION DIAL	242
-	-	1	2119580-1	MECHANICAL FEED ASSEMBLY	239
-	1	-	2844940-3	AIR FEED MODULE	238
-	1	1	1-18028-0	WASHER, FLAT, REG M8	192
-	4	4	2079383-9	SCR, BHSC, RoHS (M6 X 20)	186
-	REF	REF	994970-2	COUNTER, MAGNETIC	164
-	1	-	2119641-2	FEED CAM, AIR FEED	152
-	1	1	2168083-8	SCR, SKT HD CAP, RoHS, M4 X 16	144
-	-	1	2119653-2	FEED CAM, POST FEED	142
-	1	1	2119655-6	APPLICATOR BASIC ASSEMBLY, EF	141
-	1	1	1803518-1	RAM ASSEMBLY, EF PACIFIC	140
-	1	1	455888-6	SPACER, CRIMPER	82
-	1	1	1803607-4	DOCUMENTATION PACKAGE	71
-	2	2	2-18032-2	SCR, SET, FLT PNT, M3 X 10.0	70
-	1	1	2119740-1	TAG, IDENTIFICATION	67
-	2	2	2168078-1	SCREW, DRIVE, RH, RoHS, 2 x .188	66
-	1	1	5-18022-5	SCR, HEX HD CAP, M4 X 6.0	59
-	-	1	2063961-1	FEED FINGER	58
-	4	4	2168400-4	SHCS, LOW HEAD, RoHS, M4 X 8	57
-	2	2	2168083-2	SCR, SKT HD CAP, RoHS, M4 X 8.0	56
-	2	2	5018030-1	NUT, HEX, REG, RoHS, M3	54
-	2	2	986965-8	NUT, LOCK, HEX, TORQUE (M4)	53
-	1	-	2063961-9	FEED FINGER	51
-	1	2	18023-9	SCR, SKT HD CAP M4 X 6.0	49
-	-	1	2119652-1	FEED CAM, PRE FEED	48
-	1	1	1803602-1	SCR, BHSC, RoHS (M8 X 25)	41
-	8	8	1-18028-2	WASHER, FLAT, REG M4	33
-	2	2	2168083-9	SCR, SKT HD CAP, RoHS, M4 X 20	31
-	2	2	2168083-2	SCR, SKT HD CAP, RoHS, M4 X 8.0	29
-	1	1	240639-1	STRIPPER (MACHINING)	27
-	2	2	1-2168083-5	SCR, SKT HD CAP, RoHS, M4 X 30	25
-	1	1	1752371-5	PLATE, STRIP GUIDE	24
-	2	2	2-22281-3	SPRING, COMPRESSION	22
-	1	1	1803292-4	DRAG	20
-	1	1	1901696-3	STRIP GUIDE, REAR	19
-	1	1	1901695-3	STRIP GUIDE, FRONT	18
-	1	1	3-240641-9	SPACER	16
-	1	1	240644-1	PLATE, REAR SHEAR	11
-	-	-	-	-	10
-	1	1	690482-6	PLATE, FRONT SHEAR	9
-	1	1	4-1333219-9	ANVIL, COMBINATION	8
-	1	1	2217206-4	BLADE, SLUG	7
-	-	-	-	-	6
-	1	1	240641-9	SPACER	5
-	1	1	3-238011-5	BLOCK, CRIMPER SPACER	4
-	1	1	1-1803016-2	CRIMPER, INSULATION F	3
-	1	1	455888-6	SPACER, CRIMPER	2
-	1	1	2-456408-0	CRIMPER, WIRE PREMIUM	1
-	77	22	21	PART NO	ITEM NO

PACIFIC VERSION
Shown on sheets 3 of 4 & 4 of 4
(Atlantic version shown on sheets 1 of 4 & 2 of 4)

DIMENSIONS: mm		TOLERANCES UNLESS OTHERWISE SPECIFIED:		DWG: H. HUANG 15OCT2013		CHK: L. ZHANG 15OCT2013		NAME: TE Connectivity Harrisburg, PA 17105-3608	
0 PLC ±		1 PLC ±		APVD: J. GUO 15OCT2013		PRODUCT SPEC		SIZE: A1	
2 PLC ±		3 PLC ±		APPLICATION SPEC		CAGE CODE: 00779		DRAWING NO: C=2150375	
4 PLC ±		5 PLC ±		WEIGHT		SCALE: 1:1		SHEET 3 OF 4	
ANGLES		FINISH		RESTRICTED TO		Customer Accessible Production Drawing		REV D	

LOC		DIST		REVISIONS			
A	66	P	LTM	DESCRIPTION	DATE	DWN	APVD
		-		SEE SHEET 1			

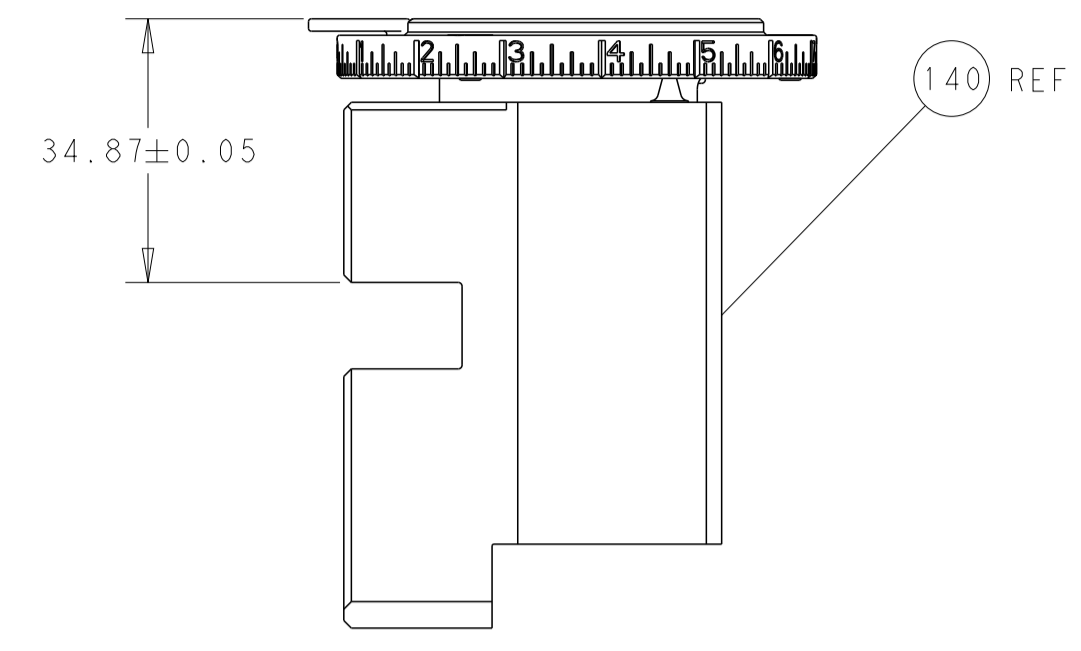

RAM SET-UP

FEED TYPE
MECHANICAL

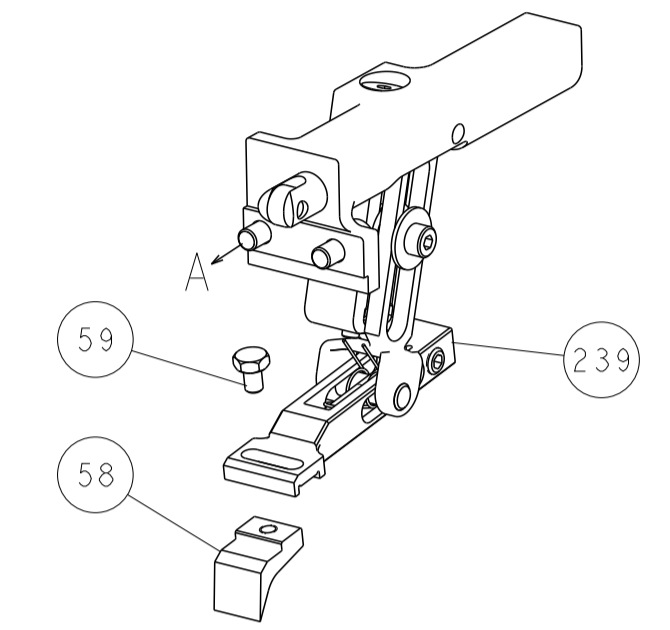

PNEUMATIC

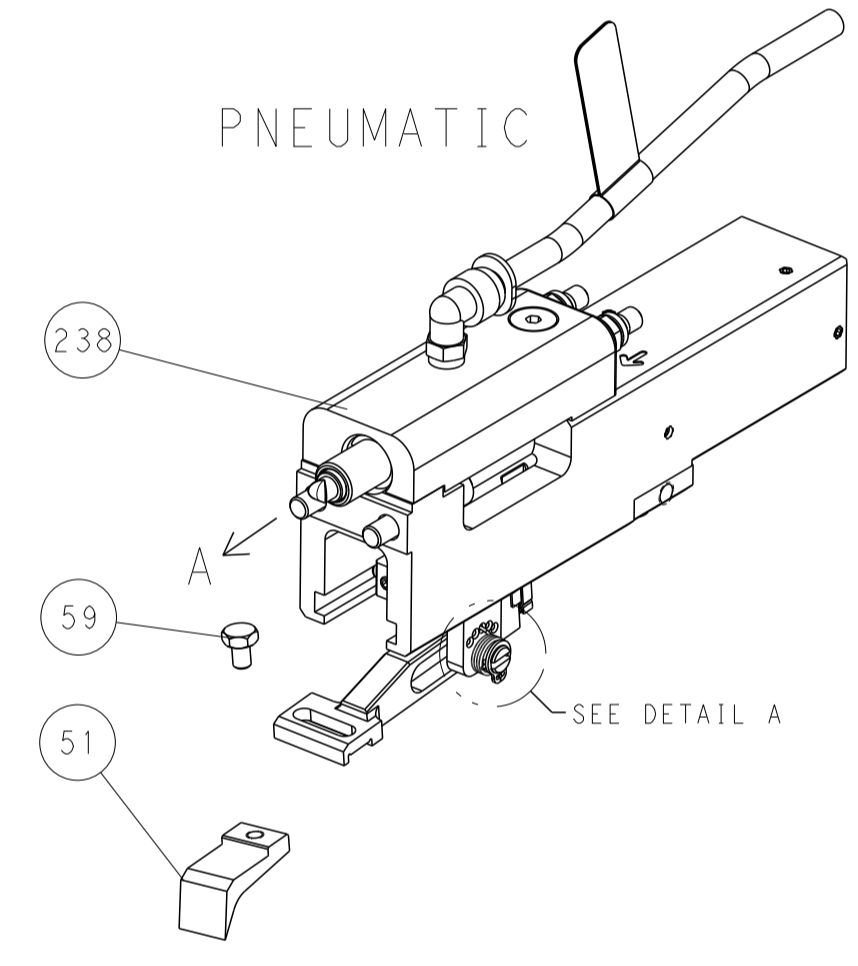

FEED SPRING
SETTING POSITION

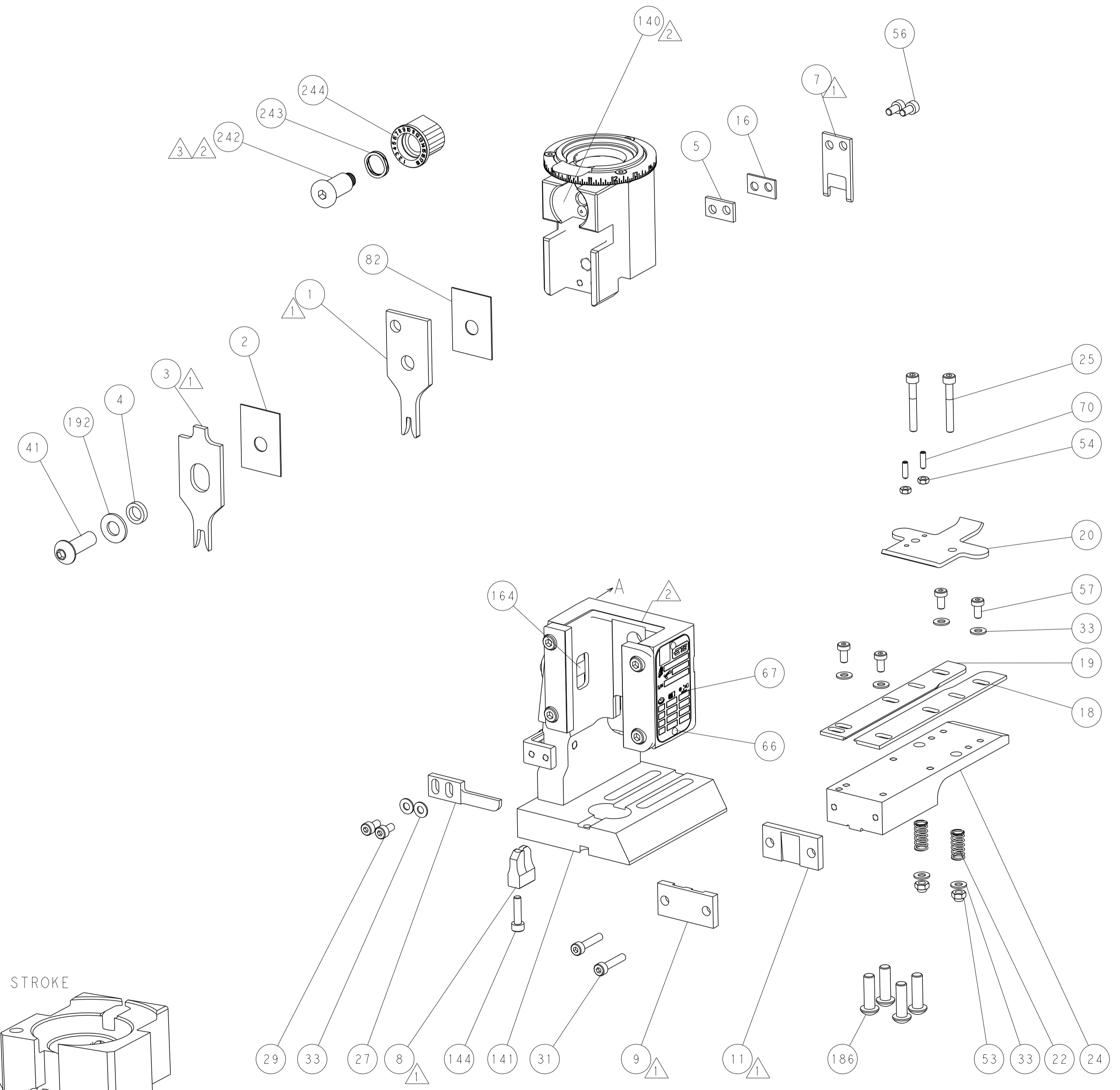
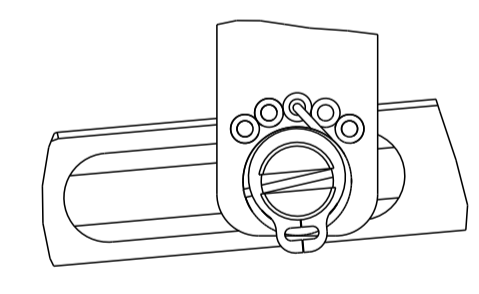

CAM POSITIONS

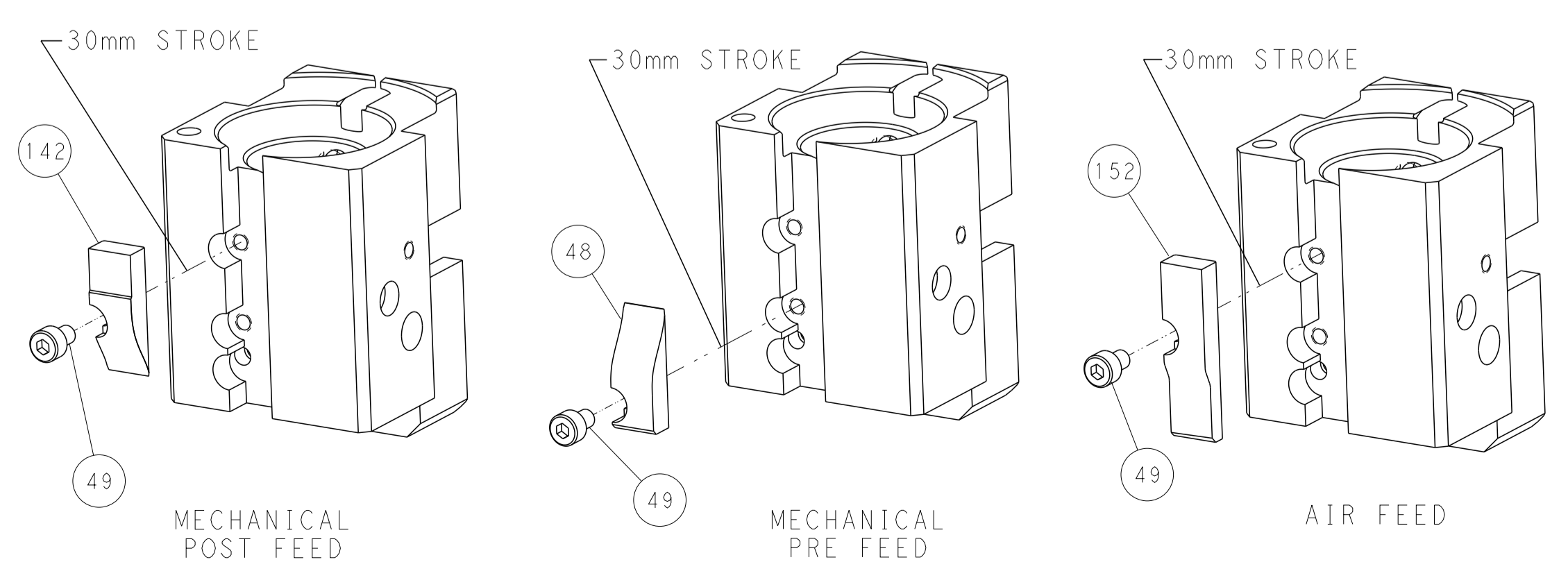

PACIFIC VERSION
 Shown on sheets 3 of 4 & 4 of 4
 (Atlantic version shown on sheets 1 of 4 & 2 of 4)

DIMENSIONS:		TOLERANCES UNLESS OTHERWISE SPECIFIED:		DWN K. HUANG 15OCT2013		CHK L. ZHANG 15OCT2013		APVD J. GUO 15OCT2013		NAME		STE TE Connectivity Harrisburg, PA 17105-3608	
mm	0 PLC ±	1 PLC ±	2 PLC ±	3 PLC ±	4 PLC ±	ANGLES ±	FINISH	PRODUCT SPEC	APPLICATION SPEC	SIZE	CAGE CODE	DRAWING NO	RESTRICTED TO
MATERIAL								WEIGHT	A 00779	©=2150375	SCALE 1:1	SHEET 4 OF 4	REV D