

REVISIONS					
P	LTR	DESCRIPTION	DATE	DWN	APVD
L1		REVISED PER ECO-20-010476	28JUL2020	RZ	RS

- ① RG-161/U,174/U,178/U,178A/U,179A/U,187/U  
188/U,196/U,21-596 & 21-598
- ② RG-179A/U,187/U,174/U,188/U,21-596 & 21-598
- ③ RG-161/U,178/U,178A/U & 196/U
- 4. SEE I.S. 1771
- 5. PARTS PACKAGED UNASSEMBLED

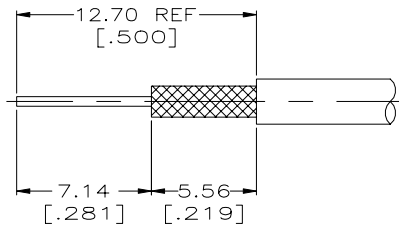

RECOMMENDED STRIP LENGTH

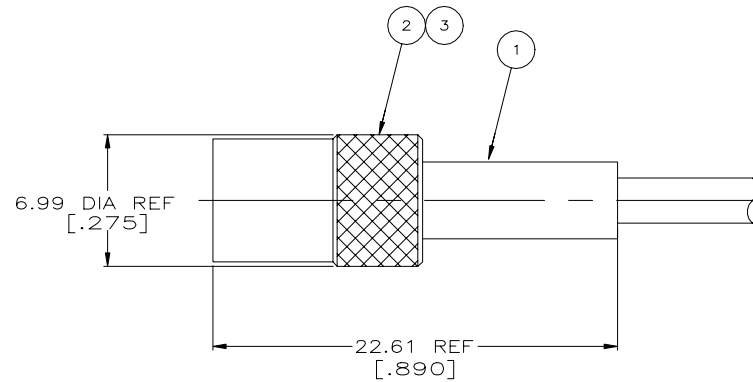

SUPERSEDED BY 2-330311-2	①	69188-1	329011	328695	329067	2-329036-2
SUPERSEDED BY 2-330311-1	②	45609 & 69142	329011	328695	329038	2-329036-1
	③	-	329011	328695	-	329036
FOR USE WITH CABLE	CRIMP TOOL	③ PLUG ASSEMBLY QTY=1	② COLLAR, RETAINING QTY=1	① FERRULE QTY=1	PART NUMBER	

THIS DRAWING IS A CONTROLLED DOCUMENT.

DWN B. SCOTT 06-24-91		TE Connectivity
CHK G. MICHAEL 02/05/93		PLUG, THREADED, MINIATURE SERIES
DIMENSIONS: INCHES	TOLERANCES UNLESS OTHERWISE SPECIFIED:	PRODUCT SPEC: 108-12013
0 PLC ± -	1 PLC ± -	APPLICATION SPEC: -
2 PLC ± 0.41 [.016]	2 PLC ± -	SIZE: A2
3 PLC ± -	3 PLC ± -	CAGE CODE: 00779
4 PLC ± -	4 PLC ± -	DRAWING NO: 329036
ANGLES ± -	FINISH: -	RESTRICTED TO: -
MATERIAL: -	WEIGHT: 0.000000	SCALE: 5:1
	CUSTOMER DRAWING	SHEET 1 of 1
		REV L1