

THIS DRAWING IS UNPUBLISHED. RELEASED FOR PUBLICATION  
 © COPYRIGHT BY TYCO ELECTRONICS CORPORATION. ALL INTERNATIONAL RIGHTS RESERVED.

LOC	DIST	REVISIONS			
P	LTR	DESCRIPTION	DATE	DWN	APVD
AF	50				
	D	REVISED PER ECR-10-006099	09JUL10	HMR	PD

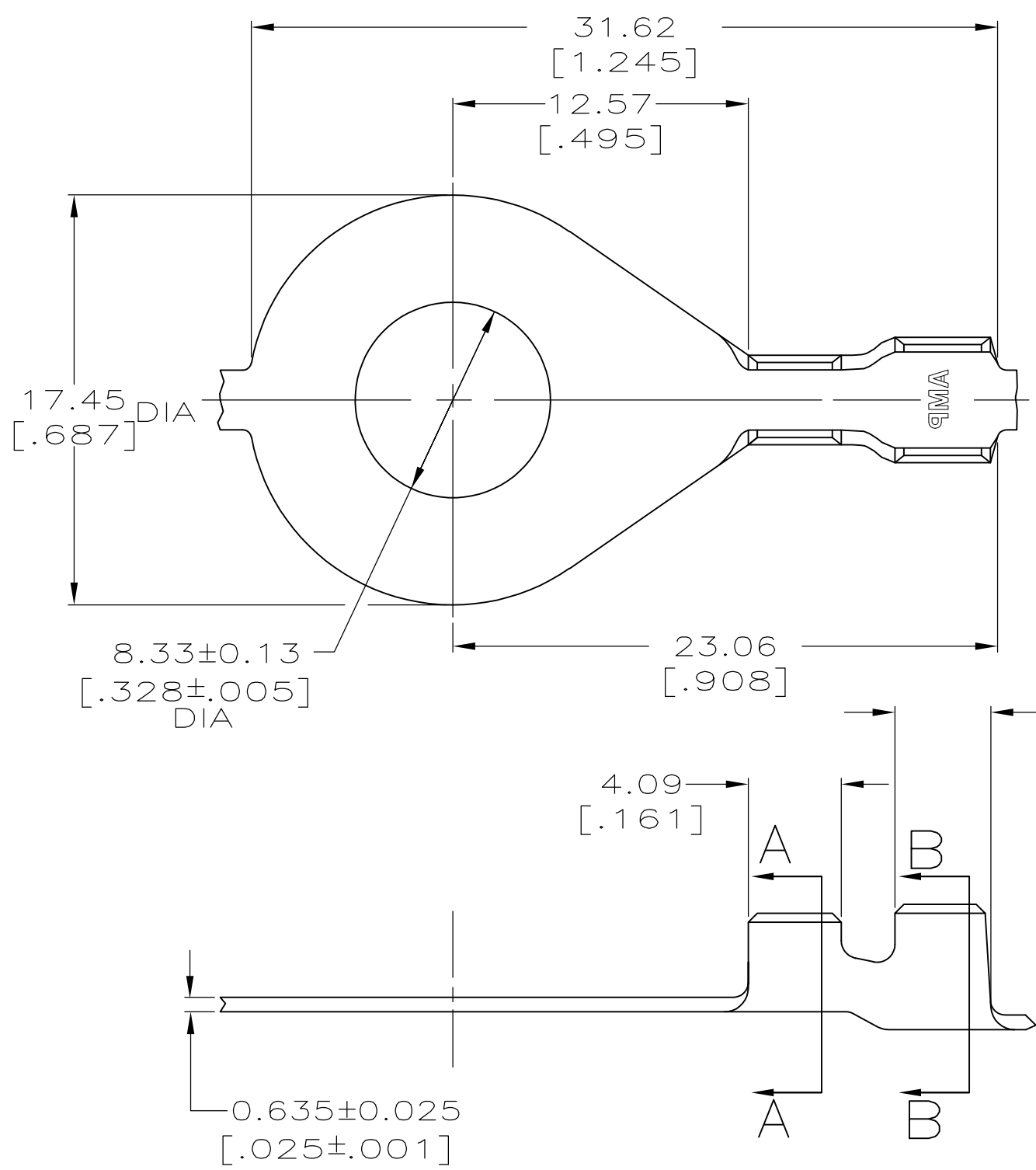

1. CONTINUOUS STRIP ON REEL.

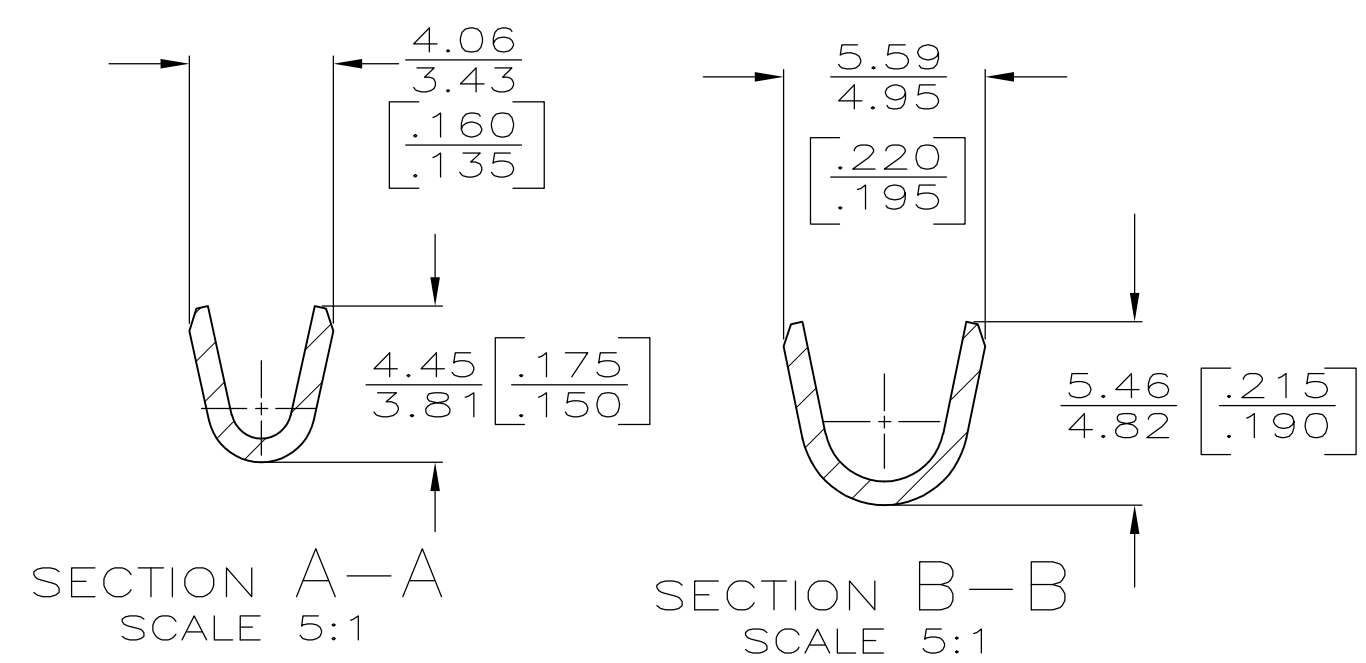

TIN	082 BRASS	2.29-3.68	[18-14] AWG	62787-2
-	TEMP A SST	[.090-.145] DIA		62787-1
FINISH	MATERIAL	INSULATION RANGE	WIRE RANGE	PART NO

THIS DRAWING IS A CONTROLLED DOCUMENT.		DWN PHILLIP M FORTNEY 30/JAN/96	Tyco Electronics Tyco Electronics Corporation Harrisburg, PA 17105-3608	
DIMENSIONS: mm [INCHES]	TOLERANCES UNLESS OTHERWISE SPECIFIED:	CHK JEFF R RUTH 30/JAN/96	NAME	
	0 PLC ± - 1 PLC ± - 2 PLC ± 0.25 [.010] 3 PLC ± - 4 PLC ± - ANGLES ± -	APVD GARY YETTER 30/JAN/96	RING	
MATERIAL SEE TABLE	FINISH SEE TABLE	PRODUCT SPEC -	APPLICATION SPEC -	RESTRICTED TO -
		WEIGHT -	SIZE A3	CAGE CODE 00779
		DRAWING NO C-62787		REV D
		CUSTOMER DRAWING		SCALE 4:1
		SHEET 1 OF 1		