

THIS DRAWING IS UNPUBLISHED. RELEASED FOR PUBLICATION, 19
 © COPYRIGHT 19 BY AMP INCORPORATED. ALL INTERNATIONAL RIGHTS RESERVED.

LOC	DIST	P	F	ZONE	LTR	DESCRIPTION	DATE	APPD
AF	50				B	REVISE PER ECR-13-013738	15FEB14	GRZ/JL

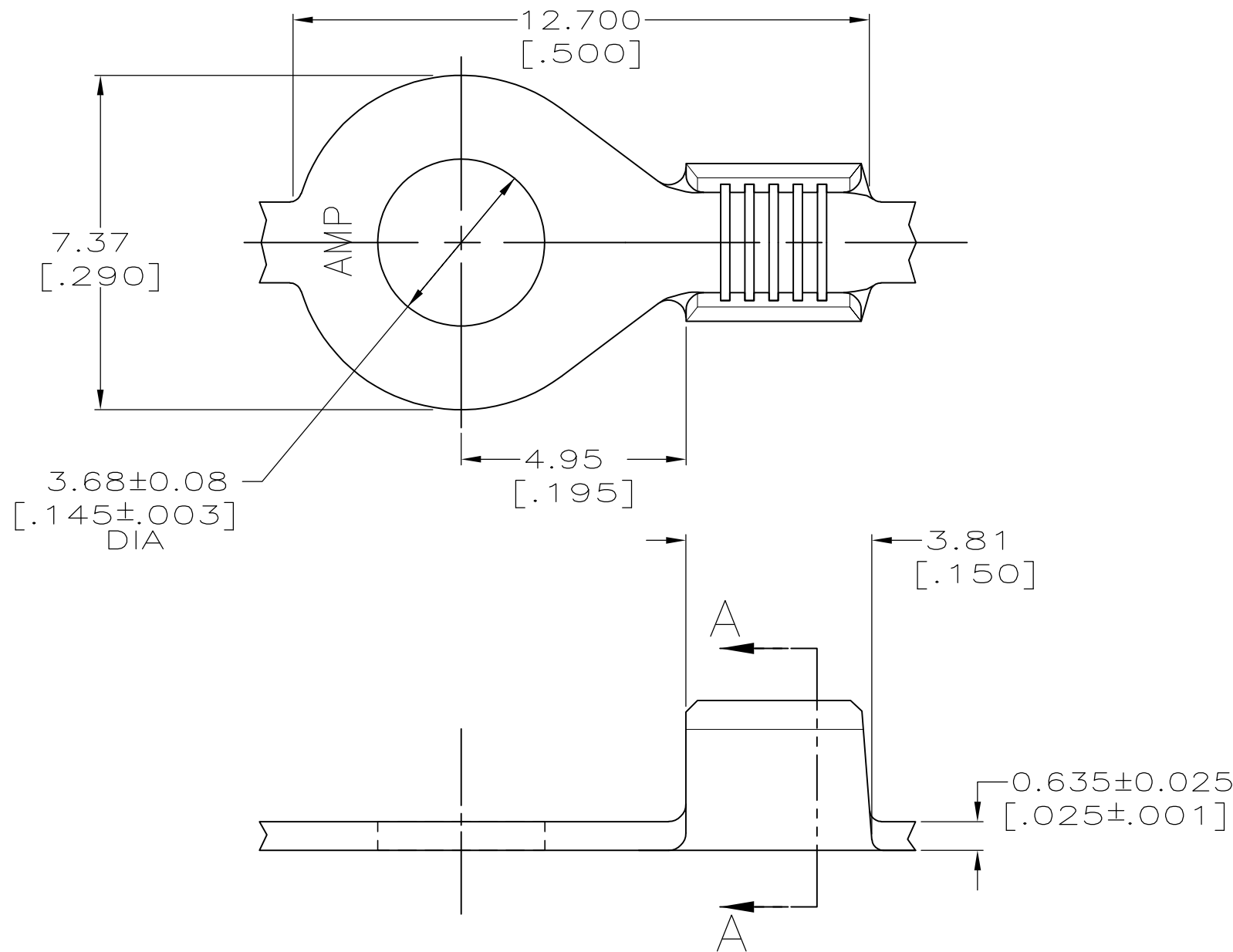

1 CONTINUOUS STRIP ON REEL.

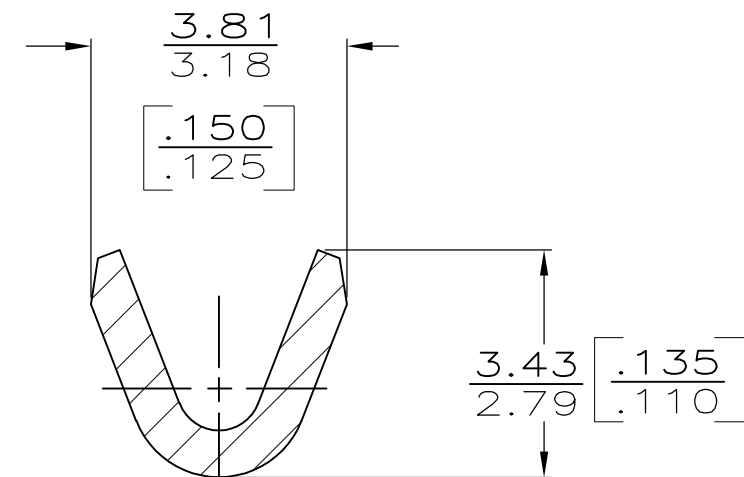

SECTION A-A
SCALE 10:1

0.64-1.02mm DIA [22-18] AWG	63649-1
MAGNET WIRE RANGE	PART NO

F	2.79 [.110]	1.47 [.058]	0.8mm ² [18]
		1.40 [.055]	0.6mm ² [20]
		1.35 [.053]	0.3mm ² [22]
TYPE	WIDTH	±0.051 [±.002] HEIGHT	WIRE
WIRE BARREL CRIMP			

DO NOT SCALE PRINT.
UNLESS SPECIFIED
DIMENSIONS IN mm [INCHES]
TOLERANCES ON:
2 PLC DEC ± 0.25 [.010]
3 PLC DEC ± -
ANGLES ± -
MATERIAL
BRASS
FINISH
0.002032 [.000080]
MIN TIN PL
PER MIL-T-10727

DR 5/6/92
P FORTNEY
CHK 5/6/92
MS FEHER
APPD 5/6/92
G YETTER
APPD 5/6/92
R WEAVILL
PRODUCT SPEC
-
APPLICATION SPEC
-
WEIGHT -

AMP AMP Incorporated Harrisburg, PA 17105-3608		
NAME RING,AMPLIVAR		
SIZE B	CAGE CODE 00779	DRAWING NO C-63649
SCALE 8:1	SHEET 1 OF 1	

THIS DRAWING IS A CONTROLLED DOCUMENT FOR AMP INCORPORATED. IT IS SUBJECT TO CHANGE AND THE CONTROLLING ENGINEERING ORGANIZATION SHOULD BE CONTACTED FOR THE LATEST REVISION.