

Figure 1

1. INTRODUCTION

To obtain information on AMP NETCONNECT products, call PRODUCT INFORMATION at the number at the bottom of this page or visit the AMP NETCONNECT website at www.ampnetconnect.com.

This instruction sheet provides termination procedures for the Shielded SL Series 110Connect Modular Jacks (Cat 6 and Cat 5e).

NOTE
All dimensions are in millimeters [with inches in brackets]. Figures are not drawn to scale.

Reasons for reissue of this sheet are provided in Section 4, REVISION SUMMARY.

2. DESCRIPTION

The jacks accept four pair, twisted-pair cable with 22 through 24 AWG solid conductors and 24 AWG stranded conductors. The maximum conductor insulation diameter is 1.45 [.057].

3. TERMINATION

1. Strip back cable jacket approximately 50.8 [2.00]. See Figure 2.
2. Fold metal foil or braid back over cable jacket leaving conductive side out (if braid is used, remove foil). This will leave approximately 50.8 [2.00] of foil over the jacket.
3. Remove clear wrapping from twisted-pair wires.

NOTE
Do NOT cut the drain wire, if present.

4. Wrap drain wire around metal foil or braid (a minimum of 360° is needed). It should be wrapped approximately 6.35 [.250] from the end of the cable jacket.

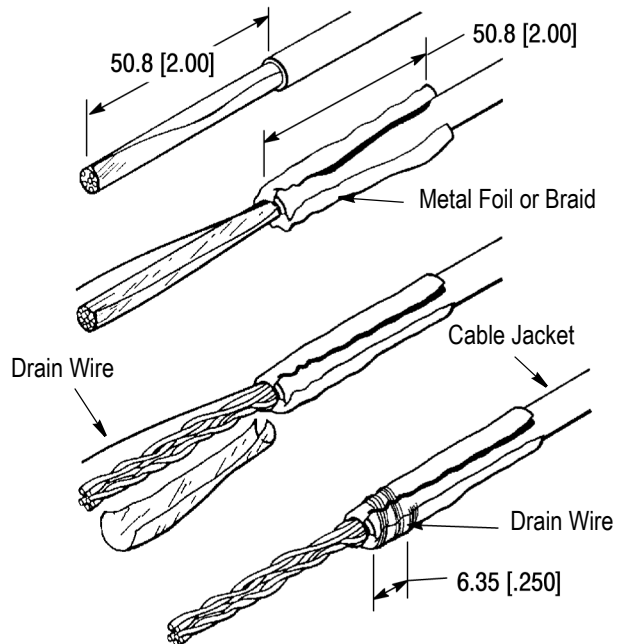

Figure 2

NOTE
Keep wire pairs twisted to within 12.7 [.50] of termination for CAT 5e Jacks. Keep wire pairs twisted to within 6.0 [.24] of termination for CAT 6 Jacks.

5. Align and lace a color-coded wire pair with the appropriate slots as indicated by the color coding on the wiring label (use minimum slack while maintaining twist, as indicated in Figure 3).

NOTE
Wire termination requires the use of Impact Tool 558418-1 or SL Jack Termination Tools 1725150-1 or 1725150-2. Refer to 408-8858 for SL Jack Termination Tool instructions.

NOTE
Set impact setting for low-impact. Orient tool so cutoff blade is on outside of block and vertical.

6. Use tool to punch wires down into slot and cut off excess wire. Remove loose wire pieces.
7. Repeat Steps 5 and 6 with all wire pairs.

AMP NETCONNECT logo is a trademark of TE Connectivity.

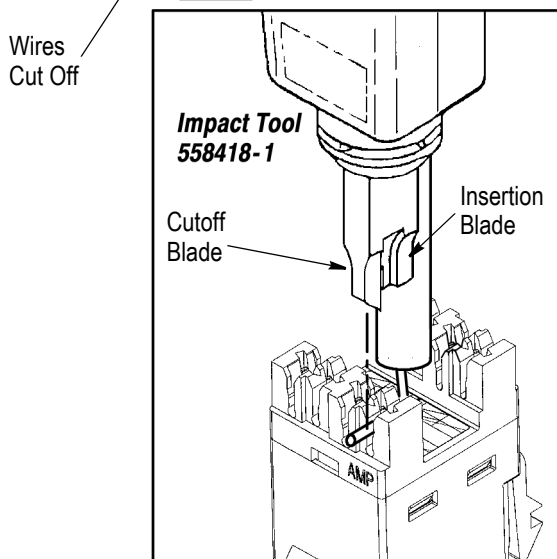
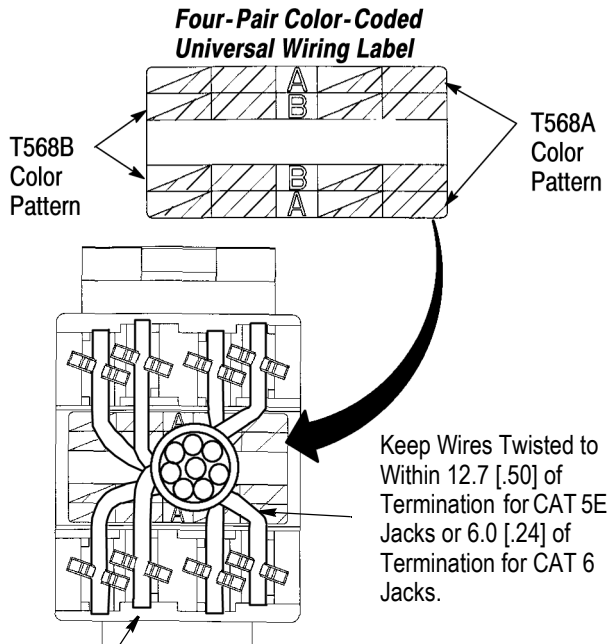

Figure 3

8. Install shield around jack as shown in Figure 4. Pinch top and bottom of shield and simultaneously pinch sides of shield. While closing shield, start belts into slots. The top and bottom of the shield should be on the inside of the tabs on the left and right sides of the shield. Continue closing until the holes in the tabs snap over the latches.

9. Refer to Figure 5 and inspect all latches of shield to ensure proper assembly. Refer to Detail A and firmly pull the belts until the shield is tight around the cable foil. Bend the belts away from the cable. Refer to Detail B and gently squeeze ribs with pliers for a tight fit. Then, bend belts as shown. Gently squeeze each belt with pliers for a tight fit. Remove excess foil or braid.

4. REVISION SUMMARY

Revisions to this instruction sheet include:

- logo change and company name change

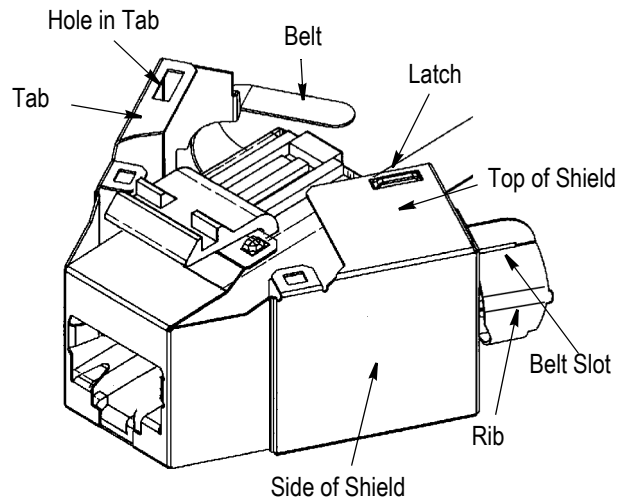

Figure 4

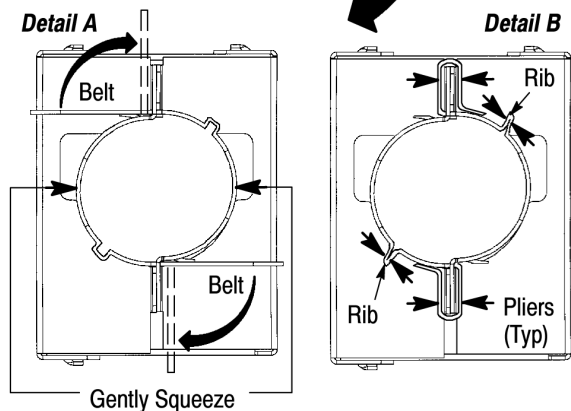
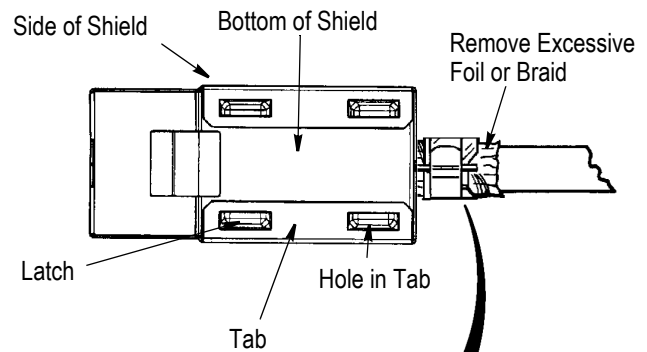

Figure 5