

- NOTES: UNLESS OTHERWISE SPECIFIED
- MARK PER TPD.
  - ITEM 1, JACKNUT ASSEMBLIES AS SHOWN ARE ASSEMBLED ON FLANGE (P/N: 9-1532139-9).
  - EPOXY AS SHOWN. EPOXY WICKING PERMITTED BEYOND POTTING WELL.
  - TERMINAL WIRES ARE TO BE SOLDER DIPPED UP TO MOUNTING SURFACE (MINIMUM).
  - LEAD IDENTIFICATION AS SHOWN ARE REFERENCE ONLY. DO NOT APPEAR ON THE PART.
  - CRIMP LEADS INTO CONTACTS PER MEP302-05.

REVISION					
ZONE	LTR	ECN	DESCRIPTION	DATE	APPROVED
	B	34005	ADD REFERENCE DIMENSIONS FOR WIRING LAYOUT	2/28/92	<i>[Signature]</i>
	C	38154	DESCRIPTION WAS MCK-NIP-15LST	2/10/92	<i>[Signature]</i>
	D	44016	UPDATE REV. LETTER.	2/24/10	TL
	E		UPDATE PER ECO-10-017486	8/25/10	PJS

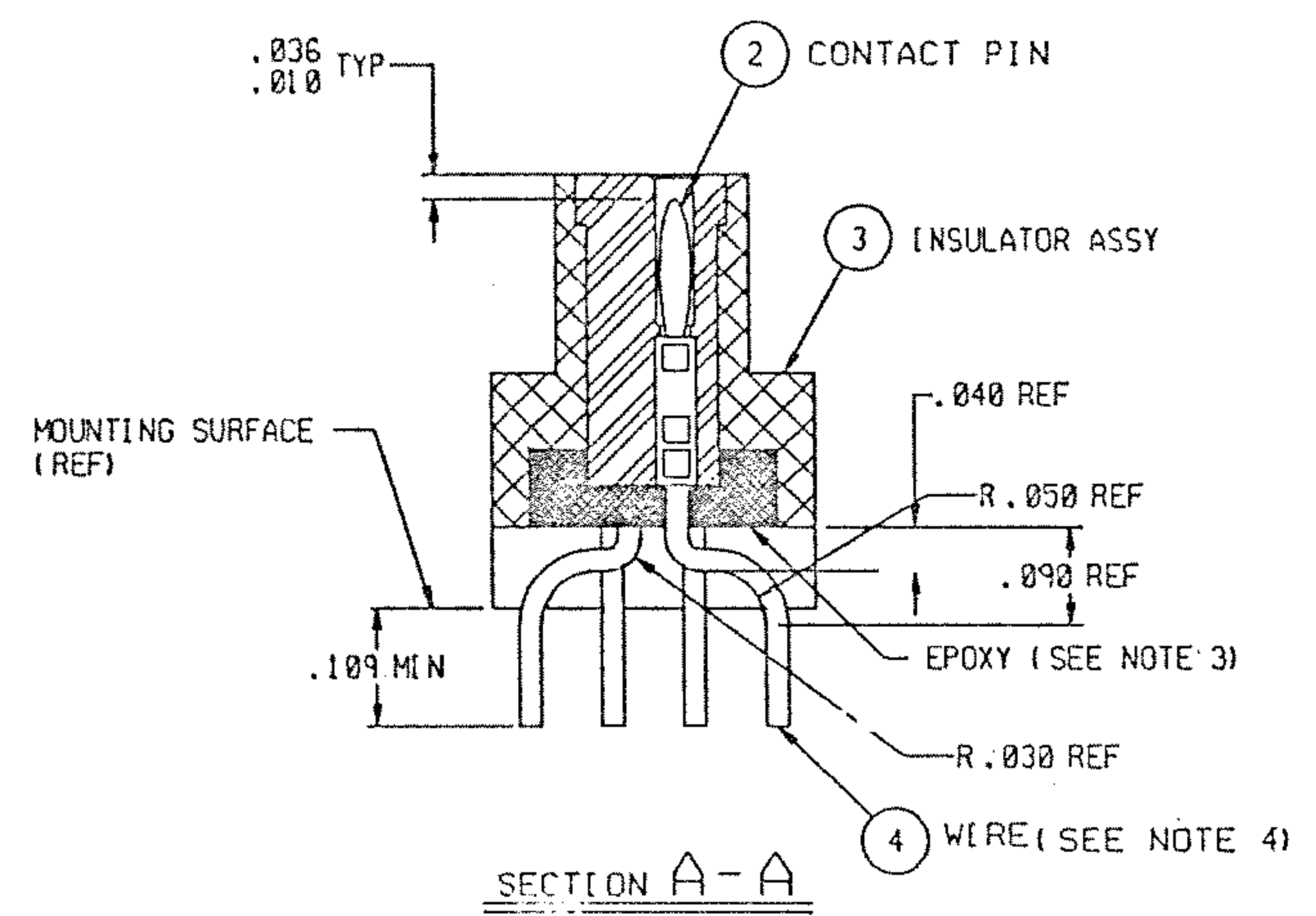

UNLESS OTHERWISE SPECIFIED DIMENSIONS ARE IN INCHES. TOLERANCE ARE:		APPROVALS		MALCO A MICRODOT COMPANY, INC. 306 PASADENA AVE., SO. PASADENA, CA 91030	
FRACTIONS ± 1/8	DECIMALS .XX ± .01 .XXX ± .005	ANGLES ± 2°	SIGNATURE	DATE	PROD CODE
MATERIAL:			CHECKED		METAL SHELL 'D' CONNECTOR, PLUG
FINISH:			PRO. ENG. <i>[Signature]</i>	2-27-92	MCK-***-P-15PST2
			APPROVED		180 DEGREE WITHOUT T.B. BLOCK
			THIS DOCUMENT IS THE PROPERTY OF MALCO, A MICRODOT CO. USE OF THIS DOCUMENT OR ANY PART OF THEREOF IS STRICTLY FORBIDDEN WITHOUT THE EXPRESS WRITTEN PERMISSION OF MALCO, A MICRODOT COMPANY.		CODE M
SIZE		CODE IDENT NO.	DRAWING NO.		
A		98278	1-1532142-4		
SCALE: NONE				SHEET 1 OF 1	