

THIS DRAWING IS UNPUBLISHED. RELEASED FOR PUBLICATION 2008
 © COPYRIGHT 2008 BY TYCO ELECTRONICS CORPORATION. ALL RIGHTS RESERVED.

LOC	DIST	REVISIONS			
P	LTR	DESCRIPTION	DATE	DWN	APVD
AI	-				

ERGOCRIMP DIE SET FOR Ø 4 mm SOCKET CONTACT - 3,0/4,0 mm²

Matrize in Kombination mit Ergocrimp Basishandzange TE P/N 539635-1 verwendbar
 Spare die set usable in combination with Ergocrimp basis hand tool TE P/N 539635-1

Matrize im Karton mit Bedienungsanleitung-Nr. 411-18480 verpackt
 Die set packed in a cardboard with instruction sheet No. 411-18480

1-1579016-1	1	3-0744013-3	Instruction Sheet	Bedienungsanleitung	6
	1	0-0519024-2	Nut M4 DIN 985	Mutter M4 DIN 985	5
	1	1-0519151-3	Screw M4x25	Schraube M4x25	4
	1	1-0519151-1	Screw M4x16	Schraube M4x16	3
	1	1-1579025-1	Locator Assembly	Drahtanschlag	2
	1	1-1579025-0	Contact Locator	Kontaktpositionierer	1
	QTY Stck	TE P/N	Description	Benennung	Pos.

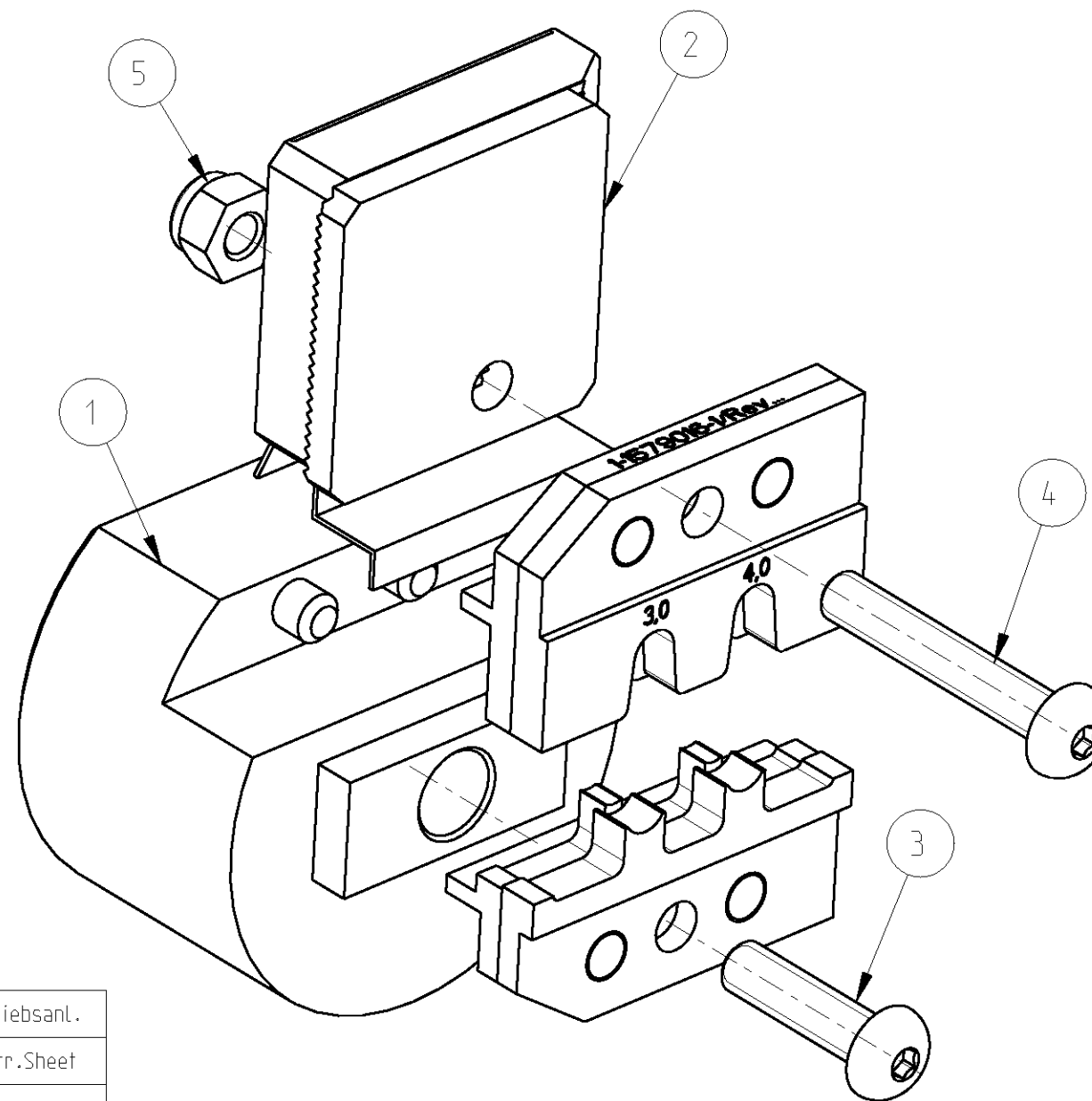

Kontakt	DGB (mm ²)	Drahtcrimp / Wire Crimp		Isolationscrimp/Insulationcrimp		Isol.Ø	Betriebsanl.
Contact	Wire Range	Höhe/Height mm	Breite/Width mm	Höhe/Height mm	Breite/Width mm	Ins.Range	Instr.Sheet
1703420	3.00	2.05 ±0.05	3.05 F	4.0	3.94 0	2.7-3.7	411-18480
	4.00	2.30 ±0.05		4.2			

<small>THIS DRAWING IS A CONTROLLED DOCUMENT FOR TYCO ELECTRONICS CORPORATION IT IS SUBJECT TO CHANGE AND THE CONTROLLING ENGINEERING ORGANIZATION SHOULD BE CONTACTED FOR THE LATEST REVISION.</small>		DWN	Ch.Witt 21FEB2008		Tyco Electronics AMP GmbH 64625 Bensheim (Germany)
DIMENSIONS: mm		CHK	-		
		APVD	-		ERGOCRIMP DIE SET FOR Ø 4 mm SOCKET CONTACT 3,0/4,0 mm ²
TOLERANCES UNLESS OTHERWISE SPECIFIED: 0 PLC ± 1 PLC ± 2 PLC ± 3 PLC ± 4 PLC ± ANGLES ±1°		PRODUCT SPEC	-		SIZE
MATERIAL - FINISH -		APPLICATION SPEC	-		CAGE CODE
		WEIGHT	200 g		DRAWING NO
		CUSTOMER DRAWING		SCALE	2:1
				SHEET	1 OF 1
				REV	A