

LOC  
A1

DIST  
-

REVISIONS

P	LTR	DESCRIPTION	DATE	DWN	APVD
	J6	ECR-16-016696	15SEP2017	GA	MKO
	J7	ECR-21-110289	15NOV2017	GR	MKO
	J8	ECR-21-123503	12MAR2022	RK	JB
	J9	REVISED PER ECR-24-201443	24APR2024	RK	WR

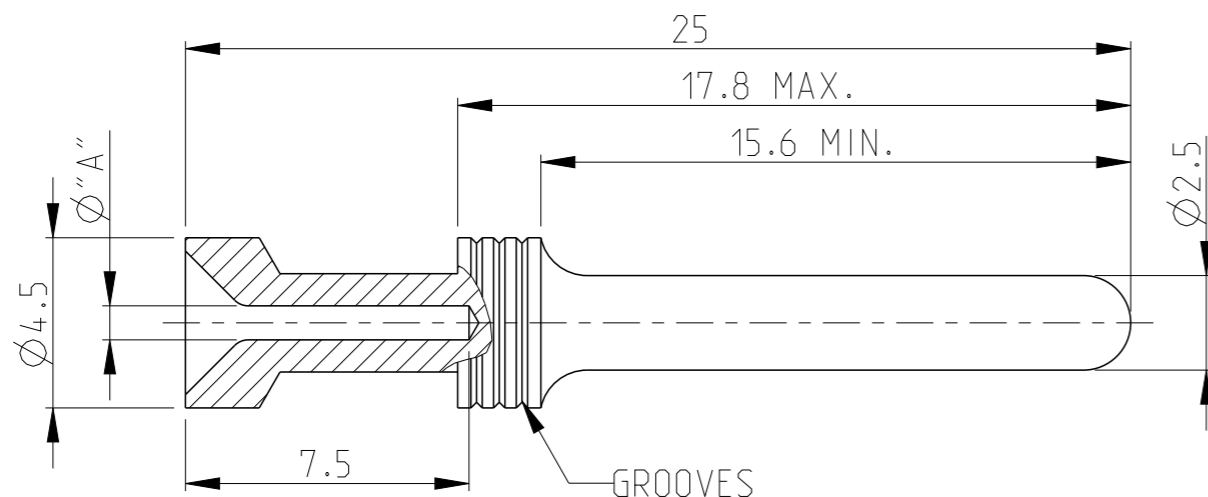

Notes

- 1 MATERIAL: BRASS
- 2 FINISH SILVER PLATING: 2 µm Ag MIN. OVER Cu
- 3 FINISH GOLD PLATING: 0.75 µm Au MIN. OVER Ni
- 4 FINISH TIN PLATING: 0.6 µm Sn MIN. OVER Cu
- 5 VENTILATION HOLE PRESENT ON ALL PARTS
- 6 WEIGHT: 1.35 g, PER PIECE (APPROX.)
- 7 PACKAGING: 50 PIECES IN POLYBAG
- 8 PACKAGING: 500 PIECES IN POLYBAG & CARTON
- 9 PACKAGING: 5000 PIECES IN POLYBAG & CARTON
- 10 PACKAGING: 20000 PIECES IN POLYBAGS & CARTONS
- 11 SUITABLE SOCKET CONTACT: CUSTOMER DRAWING 1105101
- 12 SUITABLE INSERTS: SERIES HA, HE, HVE, HVS, CUSTOMER DRAWING
- 13 SUITABLE CRIMP TOOL: PN 1-1105851-8
- 14 SUITABLE INSERTION TOOL: PN 0-1102855-6
- 15 SUITABLE EXTRACTION TOOL: PN 0-1102855-7
- 16 STANDARDS: DIN EN 61984, DIN EN 60664-1

17 OBSOLETE

HE/HA-C-Sti.Sn	CROSS SECTION	TIN	4.0	2.8	-	-	5-0	-	5-3
4,0mm <sup>2</sup>			4.0	2.8	-	-	5-0	-	5-3
HE/HA-C-Sti.Sn 2,5mm <sup>2</sup>			2.5	2.2	3	-	4-0	-	4-3
HE/HA-C-Sti.Sn 1,5mm <sup>2</sup>			1.5	1.7	2	-	3-0	-	3-3
HE/HA-C-Sti.Au 4,0mm <sup>2</sup>			4.0	2.8	-	5-2	5-9	-	-
HE/HA-C-Sti.Au 2,5mm <sup>2</sup>			2.5	2.2	3	4-2	4-9	-	-
HE/HA-C-Sti.Au 1,5mm <sup>2</sup>			1.5	1.7	2	3-2	3-9	-	-
HE/HA-C-Sti.Au 0,75-1,0mm <sup>2</sup>			0.75-1.0	1.4	1	2-2	2-9	-	-
HE/HA-C-Sti.Au 0,5mm <sup>2</sup>			0.5	1.1	-	1-2	1-9	-	-
HE/HA-C-Sti.Au 0,14-0,37mm <sup>2</sup>			0.14-0.37	0.9	3	6-2	6-9	-	-
HE/HA-C-Sti.Ag 4,0mm <sup>2</sup>			4.0	2.8	-	5-1	5-8	-	-
HE/HA-C-Sti.Ag 2,5mm <sup>2</sup>			2.5	2.2	3	4-1	4-8	7-1	-
HE/HA-C-Sti.Ag 1,5mm <sup>2</sup>			1.5	1.7	2	3-1	3-8	-	-
HE/HA-C-Sti.Ag 0,75-1,0mm <sup>2</sup>			0.75-1.0	1.4	1	2-1	2-8	-	-
HE/HA-C-Sti.Ag 0,5mm <sup>2</sup>			0.5	1.1	-	1-1	1-8	-	-
HE/HA-C-Sti.Ag 0,14-0,37mm <sup>2</sup>			0.14-0.37	0.9	3	6-1	6-8	-	-
			[MM <sup>2</sup> ]	"A"	NO.OF GROOVES	P.U.=50	P.U.=500	P.U.=5000	P.U.=20000
ORDERING TEXT	PLATING	CROSS SECTION	DIMS	MARKINGS	PACKAGING UNIT				
					BAG				BOX
					BOX				BOX

PARTS LIST

THIS DRAWING IS A CONTROLLED DOCUMENT.		DWN H.BRAUN	21Apr2010	TE Connectivity	
DIMENSIONS: mm		CHK -			
TOLERANCES UNLESS OTHERWISE SPECIFIED:		APVD T.SCHNURPFEL	29AUG2007	NAME PIN CONTACT SERIES HA, HE, HVE	
		PRODUCT SPEC 108-74004		RESTRICTED TO	
MATERIAL		APPLICATION SPEC 114-74003		SIZE A3	CAGE CODE 00779
FINISH		WEIGHT -		DRAWING NO C=1105100	
		Customer Drawing		SCALE 5:1	SHEET 1 OF 1
				REV J10	