

REVISIONS					
P	LTR	DESCRIPTION	DATE	DWN	APVD
D1		REVISED PER ECR-21-113405	31MAY2022	SS	DH

- 1 CONTINUOUS STRIP ON REELS.
- 2 MATING TAB THK 0.813±0.025 [.032±.001].
- 3 WIRE SIZE [#14-#10] AWG.
- 4 INSUL RANGE IS 3.81-5.08 [.150-.200] DIA.
- 5 THE GAP ON THE ROLLS TO BE IN CONTACT WITH THE TAB FOR THE LENGTH OF THE ROLL BEHIND THE LEAD-IN.

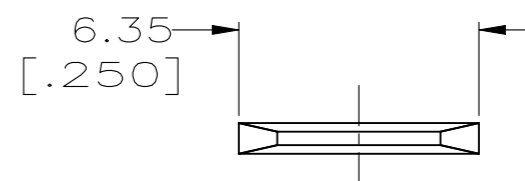
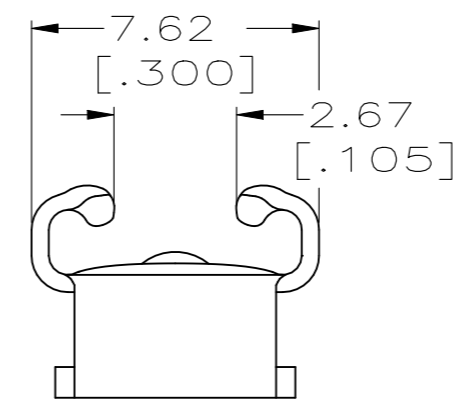
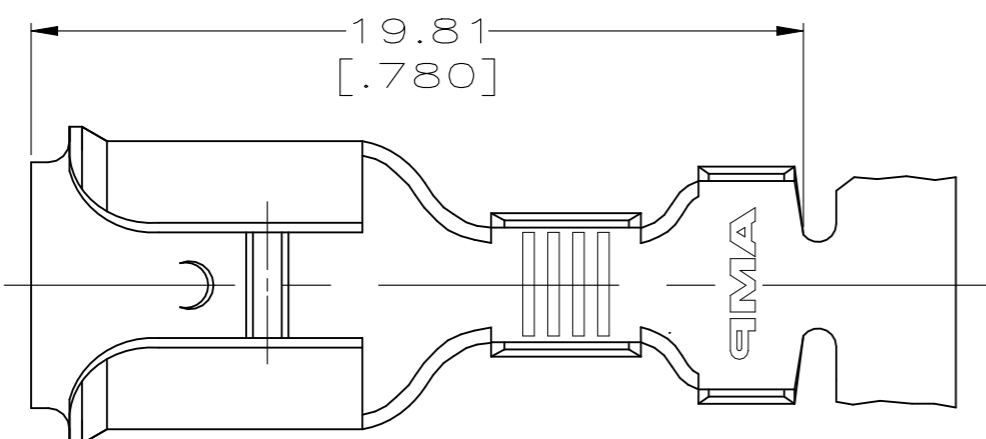

VIEW A-A

VIEW D-D

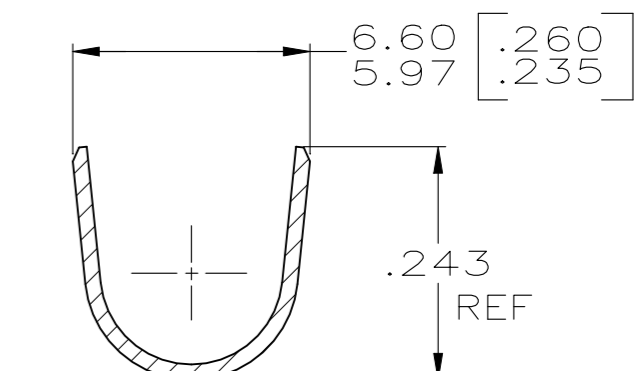
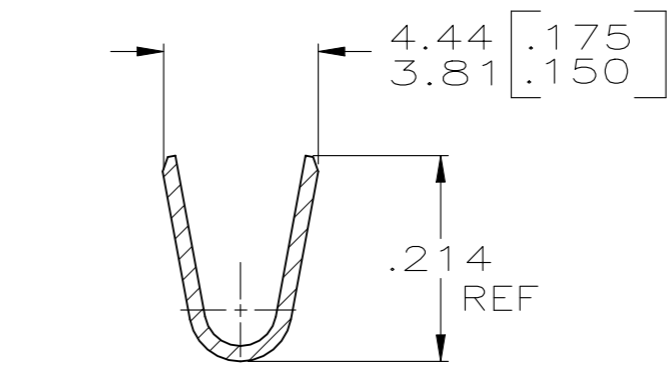
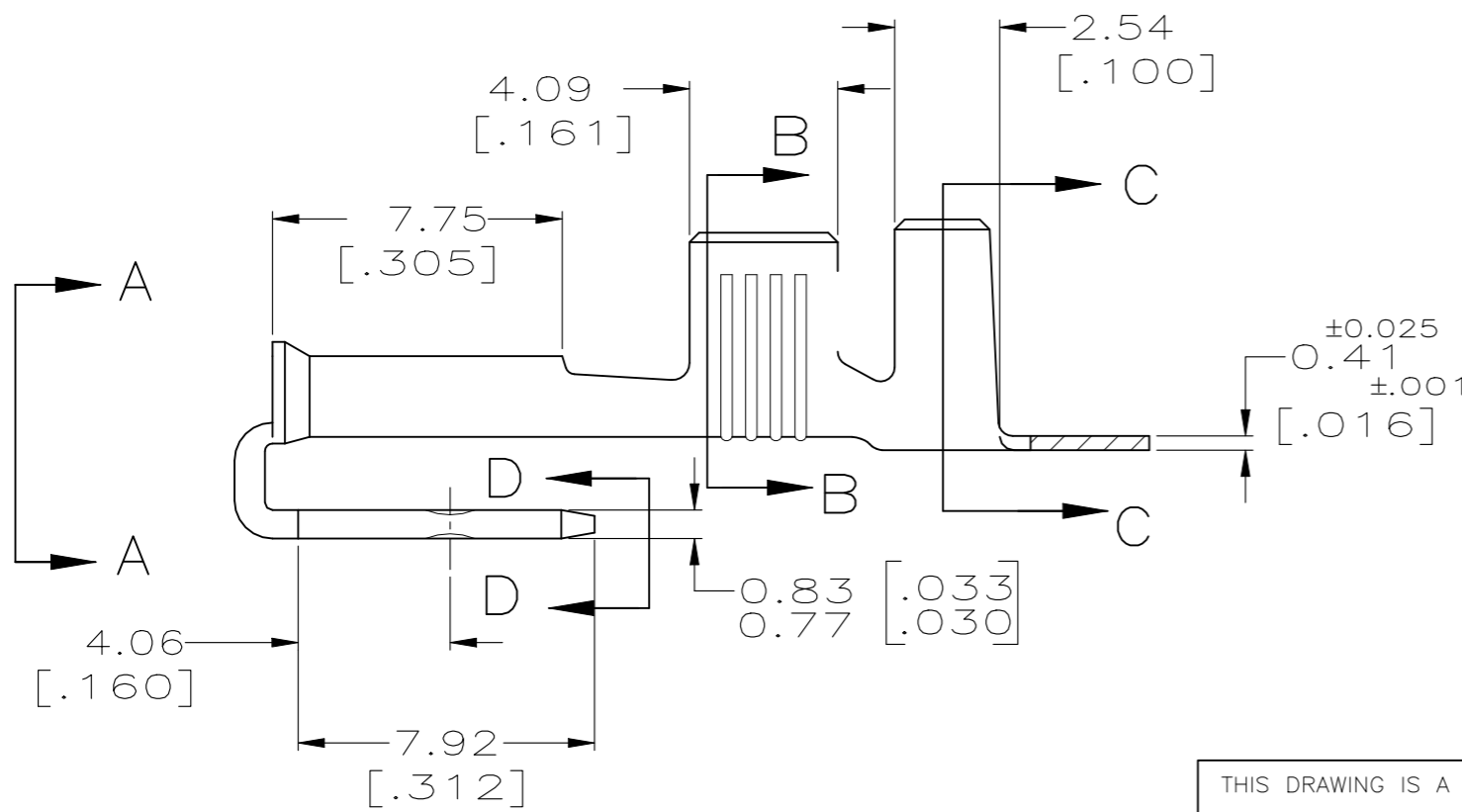

SECTION B-B

SECTION C-C

1217043-1
PART NO.

THIS DRAWING IS A CONTROLLED DOCUMENT.		DWN JR RUTH 12/18/97	TE Connectivity														
DIMENSIONS: mm [INCHES]		CHK MS FEHER 12/18/97															
TOLERANCES UNLESS OTHERWISE SPECIFIED:		APVD P DESANTIS 12/18/97	NAME														
<table border="0"> <tr><td>0 PLC</td><td>± -</td></tr> <tr><td>1 PLC</td><td>± -</td></tr> <tr><td>2 PLC</td><td>± 0.25 [.010]</td></tr> <tr><td>3 PLC</td><td>± -</td></tr> <tr><td>4 PLC</td><td>± -</td></tr> <tr><td>ANGLES</td><td>± -</td></tr> </table>		0 PLC	± -	1 PLC	± -	2 PLC	± 0.25 [.010]	3 PLC	± -	4 PLC	± -	ANGLES	± -	PRODUCT SPEC	RECEPTACLE, FASTON, PIGGYBACK, 6.35 [.250] SERIES		
0 PLC	± -																
1 PLC	± -																
2 PLC	± 0.25 [.010]																
3 PLC	± -																
4 PLC	± -																
ANGLES	± -																
MATERIAL BRASS		FINISH 0.002032 [.000080] MIN TIN	APPLICATION SPEC	SIZE A3	CAGE CODE 00779	DRAWING NO C-1217043	RESTRICTED TO										
CUSTOMER DRAWING			WEIGHT 0.000000	SCALE 5:1	SHEET 1 OF 1	REV D1											