

N° C131036-1

A4

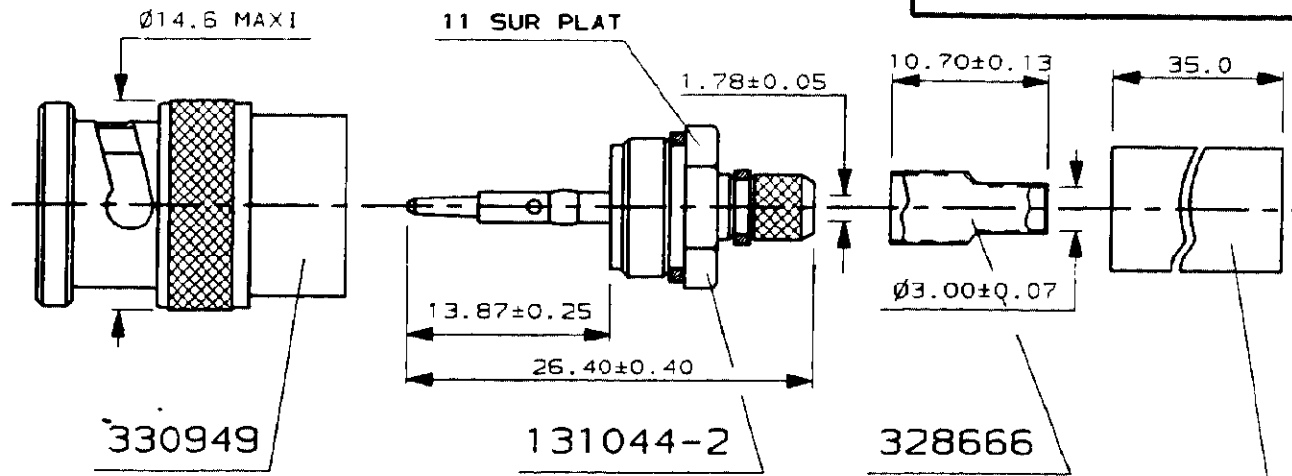
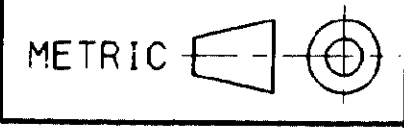

CABLE: RG188 KX3 KX22

INST. SERTISSAGE: IS 1799

OUTILLAGE: - PINCE A SERTIR 476408
 - (PINCE 69710
 + MATRICE 476410

COTES DE DENUDAGE:

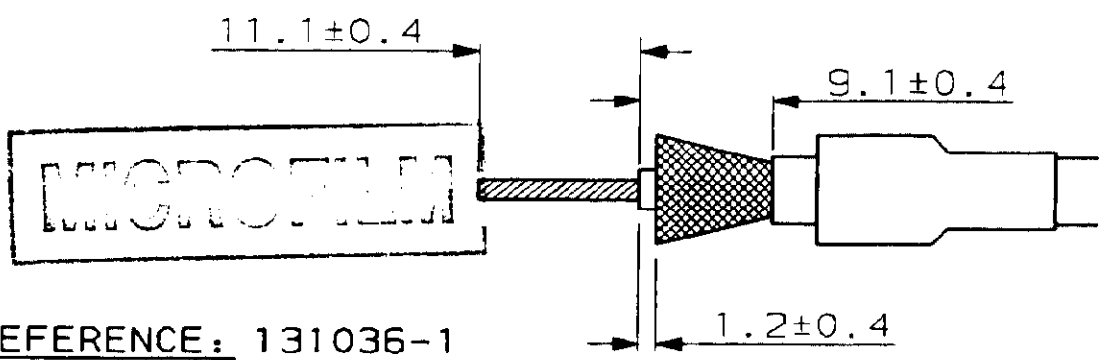

REFERENCE: 131036-1

MARQUAGE DE REF. : 1-131036-1

DIMENSIONS IN INCHES
 DO NOT SCALE DRAWING
 DIMENSIONS ON INCHES
 DIMENSIONS ON MILLIMETERS

	NUMERO	DESCRIPTION	OBSERVATION	REP.
-	-	-	-	-
-	-	©19 -- BY AMP INCORPORATED ALL RIGHTS RESERVED. AMP PRODUCTS COVERED BY PATENTS AND/OR PATENTS PENDING	DESSIN CLIENT UNIQUEMENT POUR REFERENCE	-
-	DESSEINE LE 17-12-87	MATIERE -	AMP AMP DE FRANCE 95301 PONTOISE	-
-	PAR DB	FINITION -		CLASSE BNC SERIES
-	VERIFIE LE -	DIMENS. FIL -	ISOLANT -	TYPE TYPE E
-	PAR Y. -9/3/84	TOLERANCES SAUF INDICATION ± 0.3	ECHELLE 1:1	F A N° c-131036-1 REV B
DIST	B	NOUVELLES COTES NT.N 08/84	PLAN FAIT EN CAO	ne pas modifier le coté
-	A	REP. MARQUEE ADOBE NT.N 12/83	CONN COAXIAL-FICHE DROITE	
REV	MODIFICATIONS	DES	DATE	