

REVISIONS					
REV	DATE	BY	CHK	APP'D	DESCRIPTION
E1	18JUL2024	BT	BT	KJ	REVISED PER ECN-24-275593

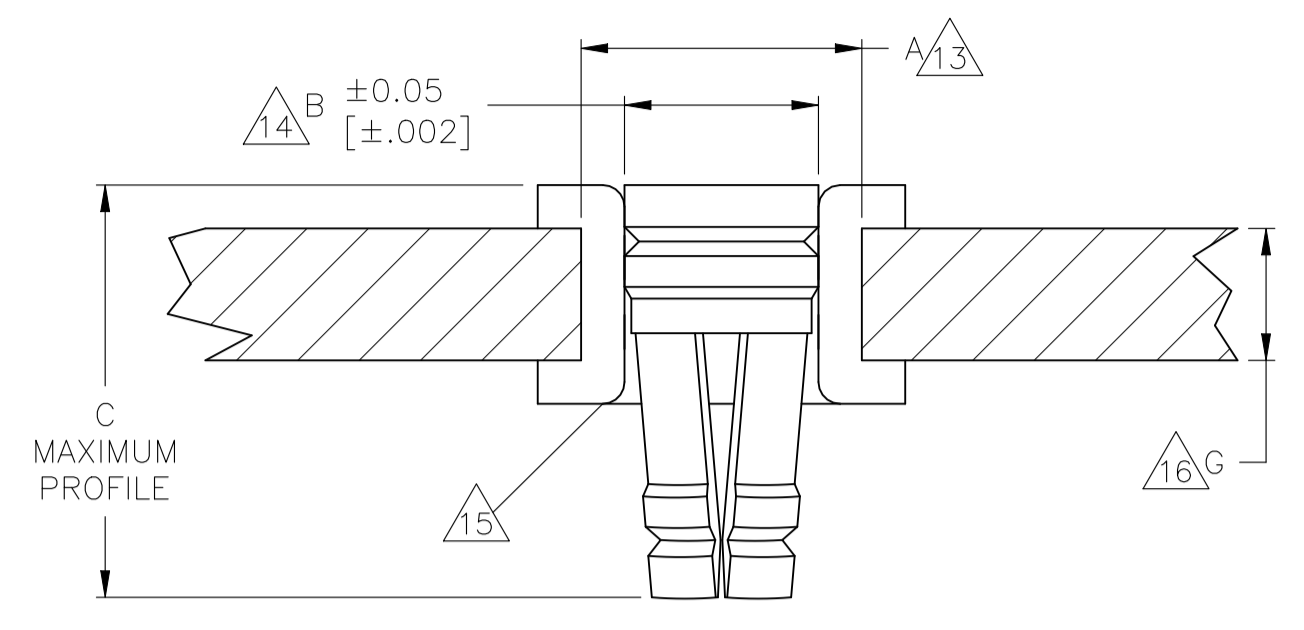
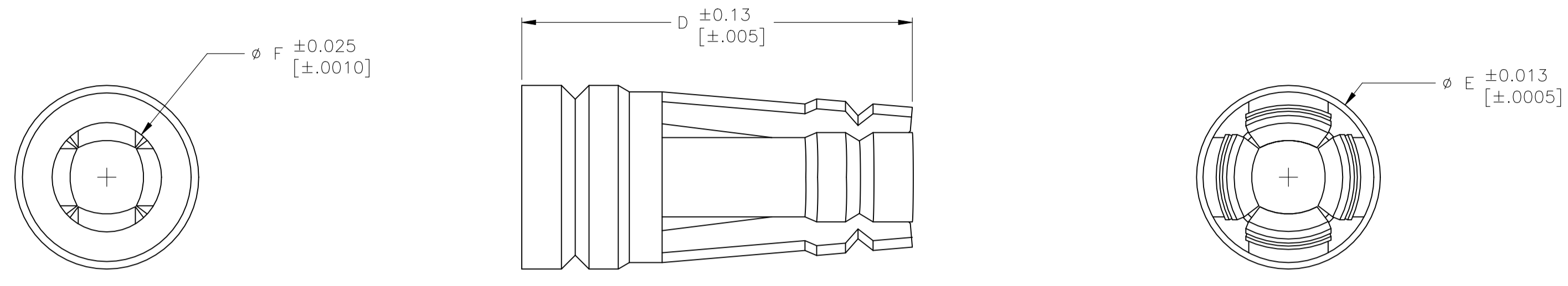

PLATED-THROUGH-HOLE REQUIREMENTS
SCALE 25:1

- 1 BERYLLIUM COPPER
- 2 .000635 [.00025] MIN. GOLD OVER .001270 [.000050] MIN. NICKEL.
- 3 .000762 [.00030] MIN. GOLD OVER .001270 [.000050] MIN. NICKEL.
- 4 .002032 [.000080] MIN. MATTE TIN-LEAD OVER .001905 [.000075] MIN. COPPER.
- 5 QUALIFIED TO MILITARY SPECIFICATION MIL-DTL-83505/6
- 6 ROUND LEAD DIAMETER 0.41-0.53 [.016-.021].
- 7 ROUND LEAD DIAMETER 0.61-0.76 [.024-.030].
- 8 ROUND LEAD DIAMETER 0.71-0.89 [.028-.035].
- 9 ROUND LEAD DIAMETER 0.91-1.14 [.036-.045].
- 10 RECTANGULAR LEAD SIZE 0.28X0.46±0.05 [.011X.018±.002].
- 11 RECTANGULAR LEAD SIZE 0.64 SQ. [.025 SQ.].
- 12 LOW INSERTION/WITHDRAWAL FORCE PRODUCT.
- 13 NOMINAL DRILL SIZE FOR PRIMARY HOLE.
- 14 FINISHED HOLE DIAMETER.
- 15 PLATED-THRU HOLE FINISH: 0.0076-0.0127 [.0003-.0005] TIN-LEAD OVER 0.001 [.0254] MIN. COPPER
- 16 MINIMUM THICKNESS FOR THE CIRCUIT BOARD.
- 17 OVERSIZED PRODUCT- FOR USE WHEN THE FINISHED HOLE DIAMETER EXCEEDS 1.15[.0453] BY 0.05 [.002] OR LESS
- 18 THESE PRODUCTS ARE BULK PACKAGED.
- 19 .002032 [.000080] MIN. MATTE TIN (LEAD FREE) OVER .001905 [.000075] MIN COPPER
- 20 PRELIMINARY PART, NOT RELEASED FOR PRODUCTION.
- 21 .0046 [.000180] MIN TIN
- 22 OBSOLETE PARTS: OBSOLETE CIS STREAMLINING PER D.RENAUD/D.SINISI
- 23 .002032 [.000080] MIN. MATTE TIN (LEAD FREE) OVER .001270 [.000050] MIN NICKEL
- 24 .002032 [.000080] MIN. MATTE TIN-LEAD OVER .001270 [.000050] MIN. COPPER.
- 25 .000127 [.000005] MIN. GOLD OVER .001270 [.000050] MIN. NICKEL.(RECOMMENDED DURABILITY -10 CYCLE)
- 26 .000254 [.000010] MIN. GOLD OVER .001270 [.000050] MIN. NICKEL.(RECOMMENDED DURABILITY -20 CYCLE)
- 27 .000381 [.000015] MIN. GOLD OVER .001270 [.000050] MIN. NICKEL.(RECOMMENDED DURABILITY -30 CYCLE)

G	F	E	D	C	B	A	PACKAGE QUANTITY	RECOMMENDED LEAD SIZE	MILITARY PART NUMBER	FINISH	AUGAT PART NUMBER (REF)	PART NUMBER
0.76 [.030]	0.66 [.026]	1.118 [.0440]	2.39 [.094]	2.54 [.100]	1.04 [.041]	1.15 [.0453]	50,000	6/10	-	27	-	2488931-1
0.76 [.030]	0.66 [.026]	1.133 MAX	2.39 [.094]	2.54 [.100]	1.04 [.041]	1.15 [.0453]	50,000	6/10	M83505/6-0015	3	M8134-HC-5P2	8-1437514-0 5
0.76 [.030]	1.07 [.042]	1.610 MAX	3.45 [.136]	3.56 [.140]	1.47 [.058]	1.61 [.0635]	50,000	8/11	-	4	8134-HC-8P3	7-1437514-1
0.76 [.030]	.097 [.038]	1.610 MAX	3.45 [.136]	3.56 [.140]	1.47 [.058]	1.61 [.0635]	50,000	7	-	23	8134-HC-6P3LF	9-1437514-1
1.27 [.050]	1.32 [.052]	2.207 MAX	3.96 [.156]	4.06 [.160]	2.08 [.082]	2.22 [.0875]	50,000	9	-	4	8134-HC-12P3	6-1437514-0
0.76 [.030]	0.66 [.026]	1.138 MAX	2.39 [.094]	2.54 [.100]	1.04 [.041]	1.15 [.0453]	50,000	6/10	-	23	8134-HC-5P3LF	9-1437514-0
0.76 [.030]	1.07 [.042]	1.588 [.0625]	3.45 [.136]	3.56 [.140]	1.47 [.058]	1.61 [.0635]	10,000	8/11	-	4	8134-HC-8P3	2-1437506-8
0.76 [.030]	.097 [.038]	1.588 [.0625]	3.45 [.136]	3.56 [.140]	1.47 [.058]	1.61 [.0635]	10,000	7	-	4	8134-HC-6P3	2-1437506-5 22
0.76 [.030]	0.66 [.026]	1.118 [.0440]	2.39 [.094]	2.54 [.100]	1.04 [.041]	1.15 [.0453]	10,000	6/10	-	4	8134-HC-6P2	2-1437506-4
0.76 [.030]	0.74 [.029]	1.168 [.0460]	2.39 [.094]	2.54 [.100]	1.09 [.043]	1.150 [.0453]	10,000	6/10	-	4	8134-HC-5P3	2-1437506-1
1.27 [.050]	1.32 [.052]	2.184 [.0860]	3.96 [.156]	4.06 [.160]	2.08 [.082]	2.22 [.0875]	10,000	9	-	2	8134-HC-5P2	2-1437506-0
0.76 [.030]	0.74 [.029]	1.168 [.0460]	2.39 [.094]	2.54 [.100]	1.09 [.043]	1.150 [.0453]	10,000	6/10	-	4	8134-HC-14P3	1-1437506-7
1.27 [.050]	1.32 [.052]	2.184 [.0860]	3.96 [.156]	4.06 [.160]	2.08 [.082]	2.22 [.0875]	10,000	9	-	4	8134-HC-14P2	1-1437506-6
0.76 [.030]	1.07 [.042]	1.588 [.0625]	3.45 [.136]	3.56 [.140]	1.47 [.058]	1.61 [.0635]	50,000	8/11	-	4	8134-HC-12P3	1-1437506-4
0.76 [.030]	.097 [.038]	1.588 [.0625]	3.45 [.136]	3.56 [.140]	1.47 [.058]	1.61 [.0635]	50,000	7	-	2	8134-HC-12P2	1-1437506-3
0.76 [.030]	0.66 [.026]	1.118 [.0440]	2.39 [.094]	2.54 [.100]	1.04 [.041]	1.15 [.0453]	50,000	6/10	-	4	8134-HC-8P3LF	8-1437514-8 20
0.76 [.030]	0.74 [.029]	1.168 [.0460]	2.39 [.094]	2.54 [.100]	1.09 [.043]	1.150 [.0453]	50,000	6/10	-	2	8134-HC-27P4	6-1437514-5 12
0.76 [.030]	0.74 [.029]	1.168 [.0460]	2.39 [.094]	2.54 [.100]	1.09 [.043]	1.150 [.0453]	50,000	6/10	-	2	8134-HC-27P3	147699-4 12
1.27 [.050]	1.32 [.052]	2.184 [.0860]	3.96 [.156]	4.06 [.160]	2.08 [.082]	2.22 [.0875]	50,000	9	M83505/6-0045	3	8134-HC-14P3	6-1437514-2
1.27 [.050]	1.32 [.052]	2.184 [.0860]	3.96 [.156]	4.06 [.160]	2.08 [.082]	2.22 [.0875]	50,000	9	-	2	8134-HC-14P2	6-1437514-1
1.27 [.050]	1.32 [.052]	2.184 [.0860]	3.96 [.156]	4.06 [.160]	2.08 [.082]	2.22 [.0875]	50,000	9	M83505/6-0045	3	8134-HC-12P2	7-1437514-9 5
0.76 [.030]	1.07 [.042]	1.588 [.0625]	3.45 [.136]	3.56 [.140]	1.47 [.058]	1.61 [.0635]	50,000	8/11	-	2	8134-HC-12P2	5-1437514-9
0.76 [.030]	0.66 [.026]	1.118 [.0440]	2.39 [.094]	2.54 [.100]	1.04 [.041]	1.15 [.0453]	50,000	6/10	M83505/6-0035	3	8134-HC-8P2	8-1437514-2 5
0.76 [.030]	.097 [.038]	1.588 [.0625]	3.45 [.136]	3.56 [.140]	1.47 [.058]	1.61 [.0635]	50,000	7	-	2	8134-HC-8P2	7-1437514-0
0.76 [.030]	0.66 [.026]	1.118 [.0440]	2.39 [.094]	2.54 [.100]	1.04 [.041]	1.15 [.0453]	50,000	6/10	M83505/6-0025	3	8134-HC-6P2	8-1437514-1 5
0.76 [.030]	.097 [.038]	1.588 [.0625]	3.45 [.136]	3.56 [.140]	1.47 [.058]	1.61 [.0635]	50,000	7	-	2	8134-HC-6P2	6-1437514-8
0.76 [.030]	0.66 [.026]	1.118 [.0440]	2.39 [.094]	2.54 [.100]	1.04 [.041]	1.15 [.0453]	50,000	6/10	-	2	8134-HC-5P2	6-1437514-6

22 OBSOLETE

THIS DRAWING IS A CONTROLLED DOCUMENT.

DIMENSIONS: mm

TOLERANCES UNLESS OTHERWISE SPECIFIED:

0. PLC	± .0005
1. PLC	± .0005
2. PLC	± .0005
3. PLC	± .0005
4. PLC	± .0005
ANGLES	± .0005

MATERIAL: 1

FINISH: -

TE Connectivity

HOLITE CONTACTS

108-1979

114-13033

0.000000

00779

147699

SCALE: NTS

SHEET: 1 of 1

REV: E1