

4

3

2

1

THIS DRAWING IS UNPUBLISHED.

RELEASED FOR PUBLICATION

ALL RIGHTS RESERVED.

© COPYRIGHT -

REVISIONS

P	LTR	DESCRIPTION	DATE	DWN	APVD
	A1	REVISED PER ECR-17-012771	01SEP2017	BDA	TD

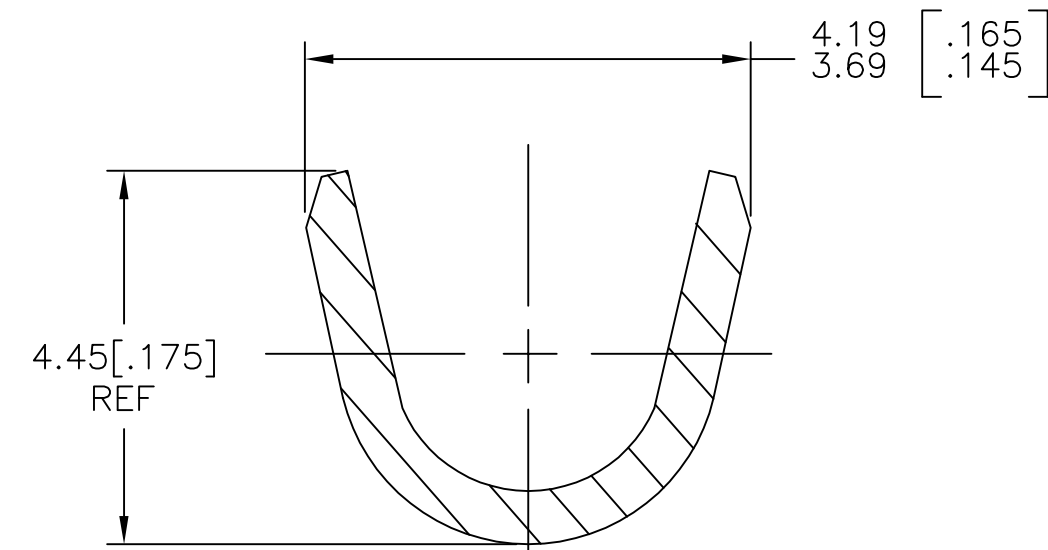
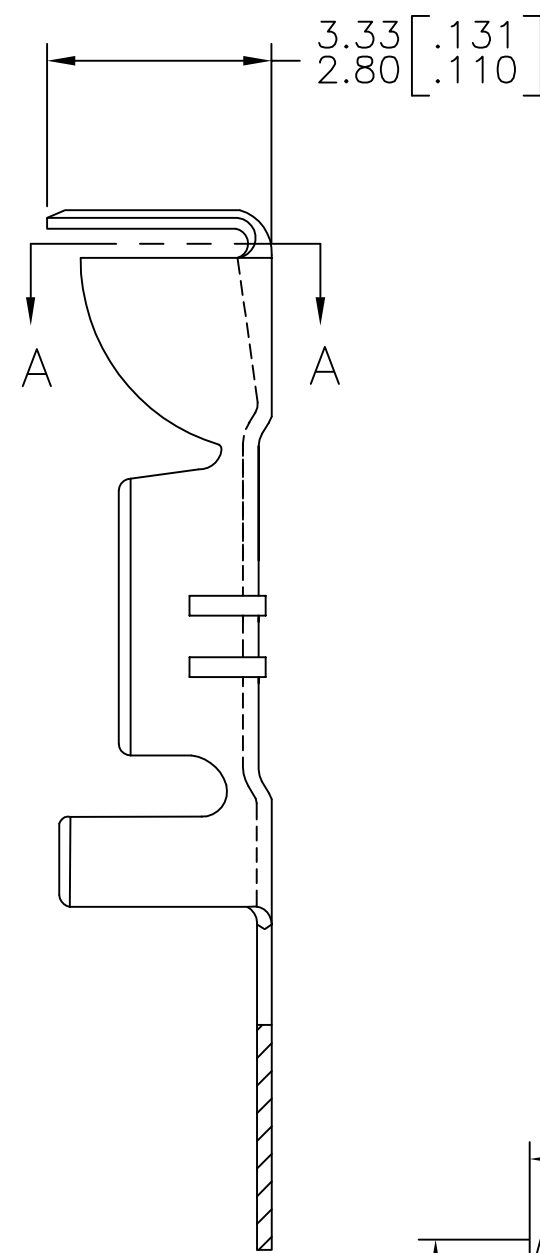
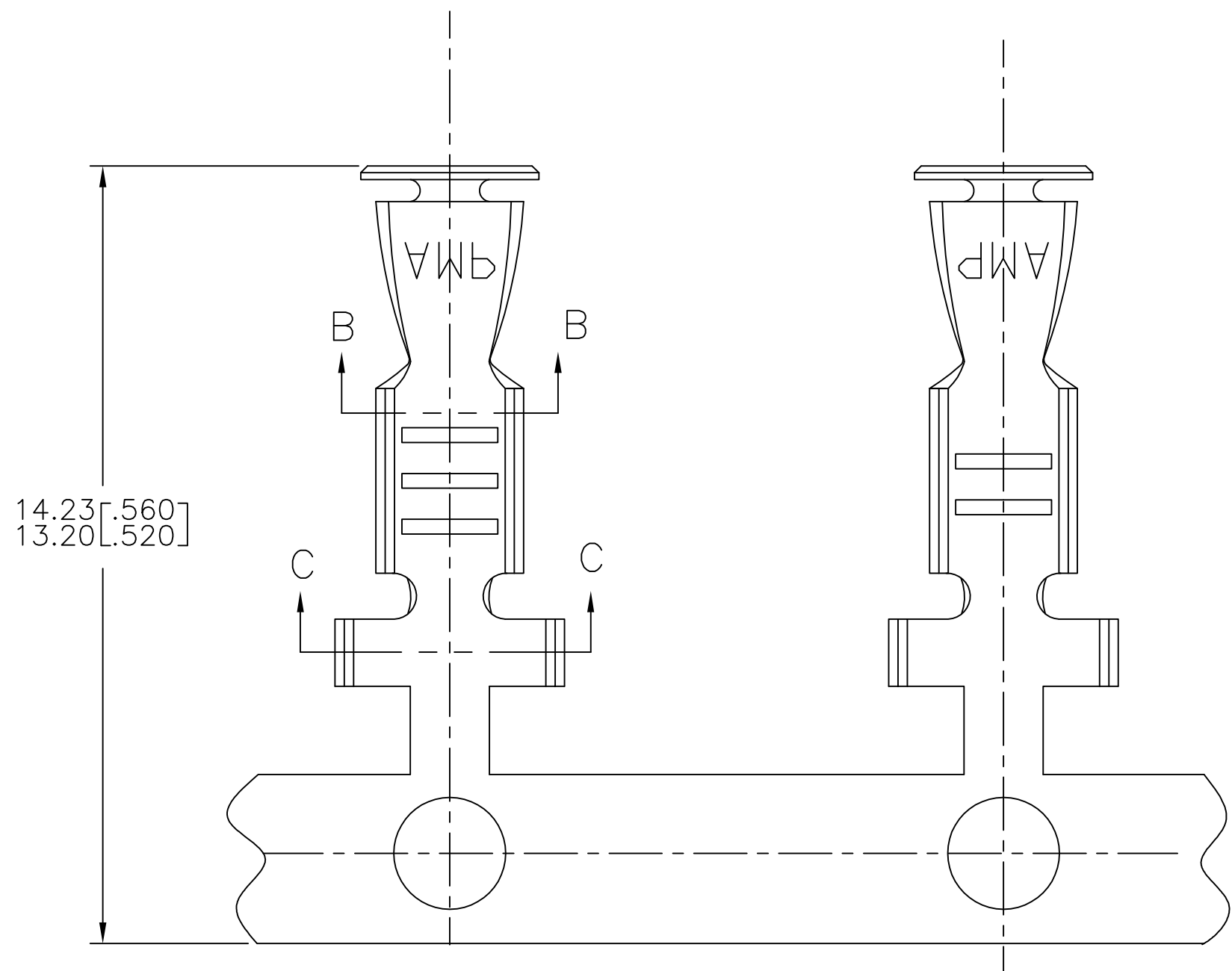

SECTION C-C

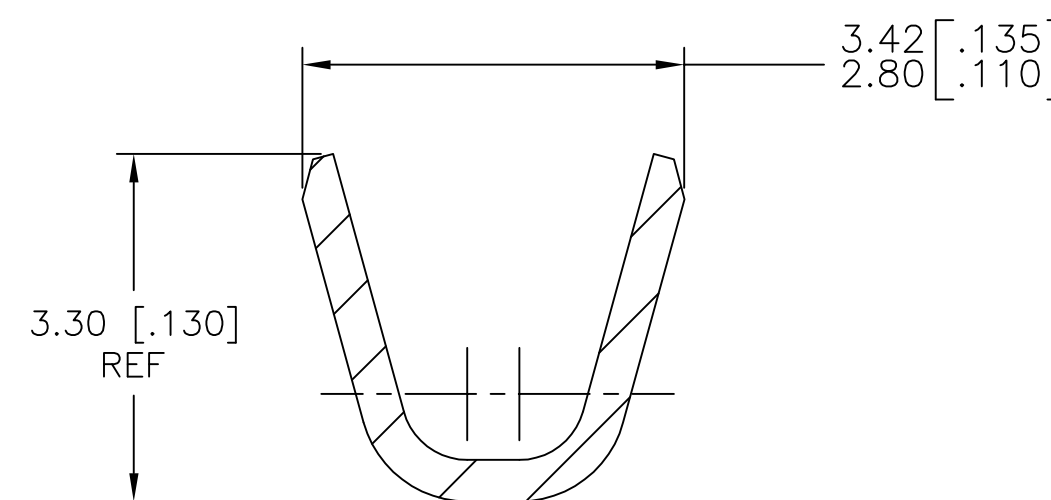

SECTION B-B

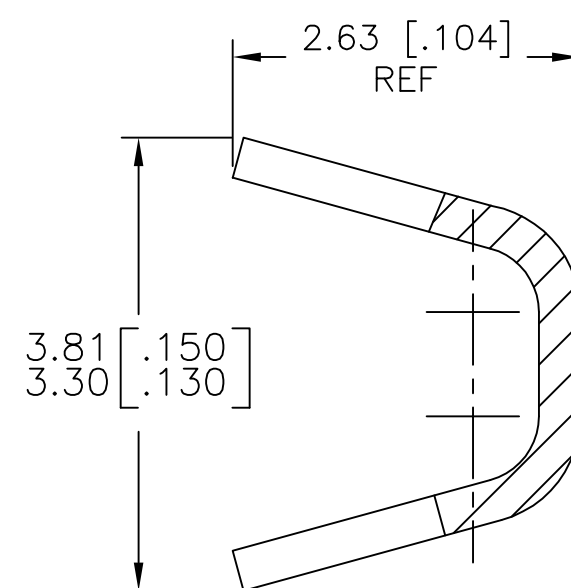

SECTION A-A

CODE	MATERIAL DESCRIPTION
A	BRASS
CODE	PLATING SPECIFICATION
1	PRE TIN
2	ELECTRO TIN

DIRECTION OFF TOP OF REEL

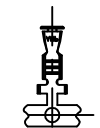

WIRE RANGE: 20-16
 INS. RANGE: 2.29-2.79
 [.090-.110]

OBSELETE	SIZE	CAGE CODE	DRAWING NO	RESTRICTED TO
	5M	A-2	150528-2	
	5M	A-1	150528-1	
	QTY/REEL	MAT.	PART NO	

THIS DRAWING IS A CONTROLLED DOCUMENT.

DIMENSIONS: mm [INCHES]

TOLERANCES UNLESS OTHERWISE SPECIFIED:

0 PLC	± -
1 PLC	± -
2 PLC	± 0.40[.015]
3 PLC	± -
4 PLC	± -
ANGLES	± -
FINISH	-

MATERIAL SEE TABLE

DWN RAVI S 22NOV2016

CHK LI DAISY 22NOV2016

APVD DING TIM 22NOV2016

PRODUCT SPEC

APPLICATION SPEC

WEIGHT -

CUSTOMER DRAWING

TE Connectivity

NAME

BUTTON CONTACT

SIZE	CAGE CODE	DRAWING NO	RESTRICTED TO
A2	00779	C=150528	-

SCALE	SHEET	REV
6:1	1 of 1	A1