

THIS DRAWING IS UNPUBLISHED. RELEASED FOR PUBLICATION - ,14AUG07

© COPYRIGHT - BY TYCO ELECTRONICS CORPORATION. ALL RIGHTS RESERVED.

LOC	DIST	REVISIONS					
GP	00	P	LTR	DESCRIPTION	DATE	DWN	APVD
			A2	REVISE TAB ANGLES	28JUN13	JL	ML

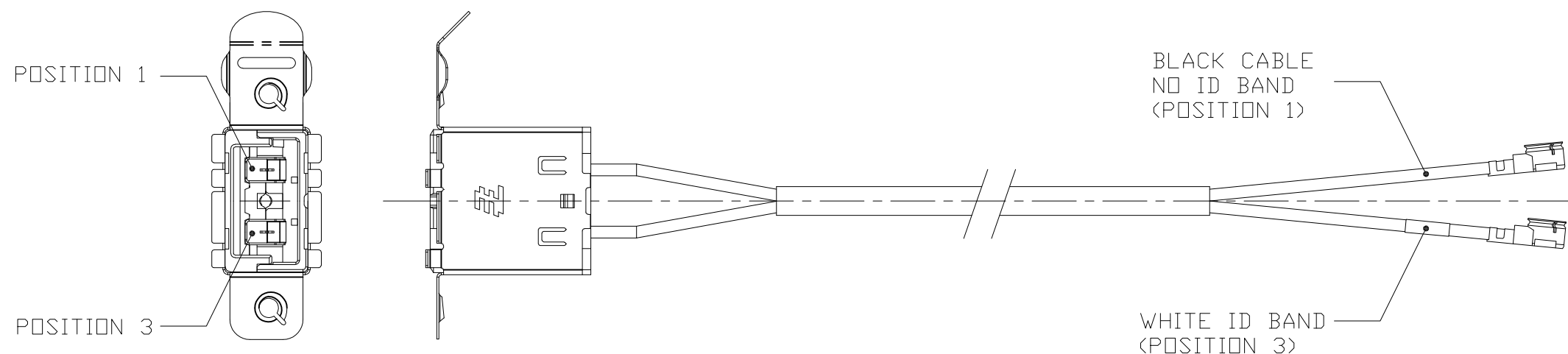

- 1 MATERIAL  
HOUSING: LCP UL94V0,COLOR:BLACK  
CONTACTS AND SHIELDS:COPPER ALLOY  
SHELL:STELL,STAINLESS,1/2 HARD
- 2 PLATING  
CONFORMS TO THE REQUIREMENTS OF  
EIA/ECA-364-1000.01A  
AND TYCO ELECTRONICS SPECIFICATION  
108-2302
- 3 FEATURES ACCEPT 4-40 THREAD SCREWS
- 4 CABLE  
ø1.32MM,50 OHMS  
FEP INSULATED COAX  
JACKET COLOR:BLACK
- 5 CONNECTOR PENDING UL RECOGNITION  
AND CSA CERTIFICATION WITH A MINIMUM  
FLAMMABILITY RATING OF UL 94V-1
- 6 CABLE IS UL RECOGNIZED AWM WITH A  
MIN TEMPERATURE RAING OF 80°C,AND A  
MINIMUM FALAMMABILITY RATING.
- 7 PRODUCT AND PROCESSING MEETS  
REQUIREMENTS OF TYCO ELECTRONICS  
STANDARD 230-702
- 8 VSWR 1.7 MAX UP TO 6 GHz

VDYXY	441.9±7.0MM	600.0±10.0MM	1559153-1
DELL PN	HEAT SHRINK LENGTH	CABLE LENTH	TE PN

THIS DRAWING IS A CONTROLLED DOCUMENT.		DWN Mac King 29JUL09	Tyco Electronics Corporation Harrisburg, PA 17105-3608	
DIMENSIONS: mm [INCHES]		CHK Lessie Zhang 29JUL09	NAME	
TOLERANCES UNLESS OTHERWISE SPECIFIED:		APVD Johan Chandra 29JUL09	CABLE ASSEMBLY RECEPTACLE PANEL MOUNT,3 PORT SLIDE AND LOCK,QLS	
0 PLC ± - 1 PLC ± - 2 PLC ± 0.3 3 PLC ± 0.13 4 PLC ± - ANGLES ± -		PRODUCT SPEC 108-2302	SIZE	CAGE CODE
MATERIAL		APPLICATION SPEC	DRAWING NO	RESTRICTED TO
FINISH		WEIGHT	A3 00779	G-1559153
1 4		CUSTOMER DRAWING		SCALE N.T.S. SHEET 1 OF 2 REV A2

THIS DRAWING IS UNPUBLISHED. RELEASED FOR PUBLICATION - ,14AUG07  
 © COPYRIGHT - BY TYCO ELECTRONICS CORPORATION. ALL RIGHTS RESERVED.

LOC	DIST	REVISIONS			
P	LTR	DESCRIPTION	DATE	DWN	APVD
GP	00	SEE SHEET 1	-	-	-

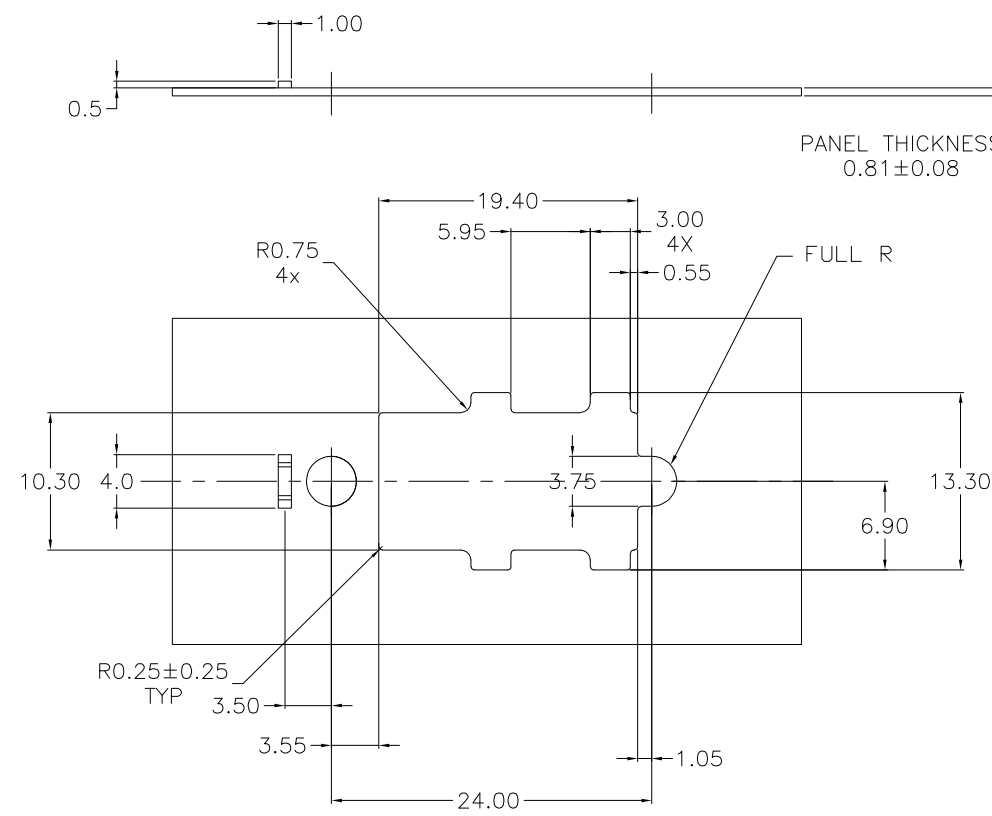
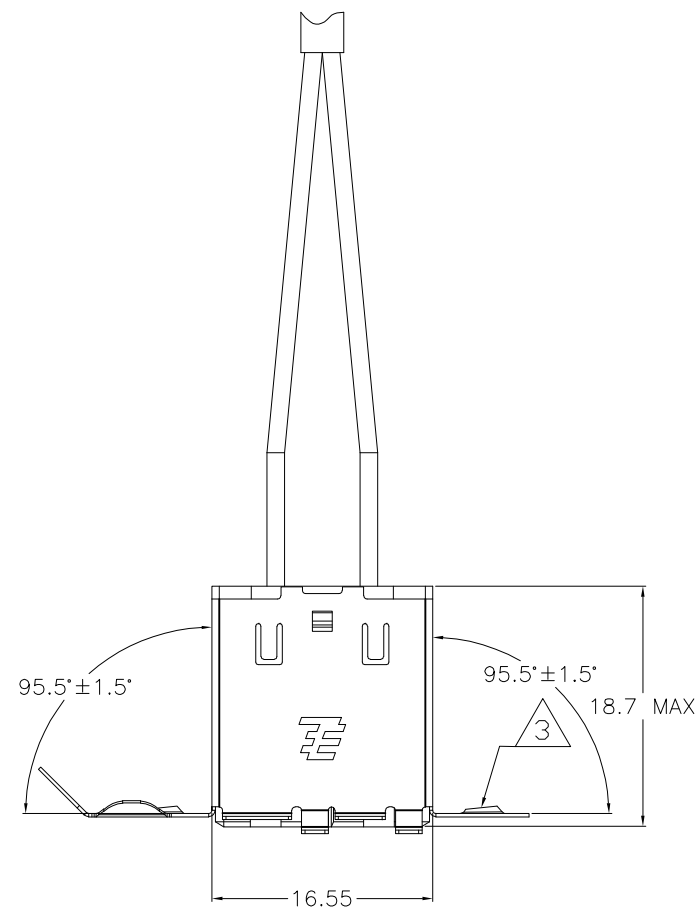

RECOMMENDED PANEL CUT-OUT  
(PANEL FACE SHOWN)

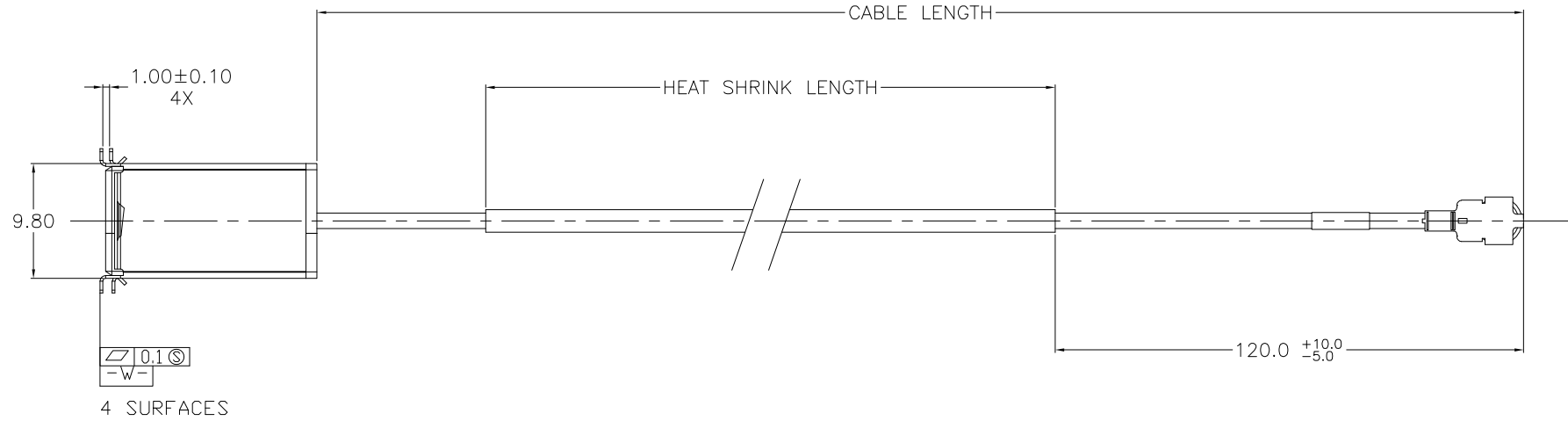
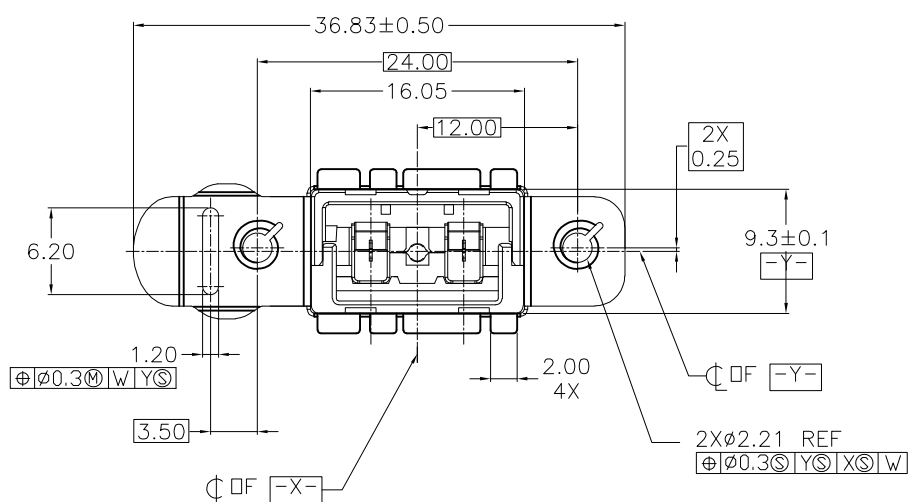

THIS DRAWING IS A CONTROLLED DOCUMENT.		DWN Mac King 29JUL09	Tyco Electronics Corporation Harrisburg, PA 17105-3608		
DIMENSIONS: mm [INCHES]		CHK Lessie Zhang 29JUL09	NAME		
TOLERANCES UNLESS OTHERWISE SPECIFIED:		APVD Johan Chandra 29JUL09	CABLE ASSEMBLY RECEPTACLE PANEL MOUNT, 3 PORT SLIDE AND LOCK, QSL		
0 PLC ± -		PRODUCT SPEC 108-2302	SIZE	CAGE CODE	DRAWING NO
1 PLC ± -		APPLICATION SPEC	A3	00779	C-1559153
2 PLC ± 0.3		WEIGHT	RESTRICTED TO		
3 PLC ± 0.13		-	-		
4 PLC ± -		CUSTOMER DRAWING	SCALE	SHEET	REV
ANGLES ± -		-	N.T.S.	2 OF 2	A2
FINISH		-			
MATERIAL		-			