

THIS DRAWING IS UNPUBLISHED. RELEASED FOR PUBLICATION  
 © COPYRIGHT - By - ALL RIGHTS RESERVED.

REVISIONS				
P	LTR	DESCRIPTION	DATE	APVD
C		REVISED PER ECO-17-002903	20MAR2017	AP DG

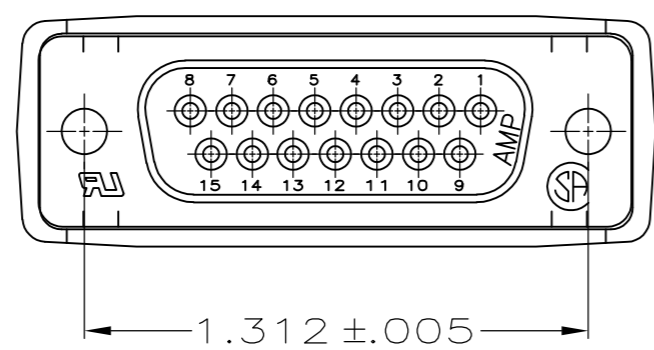
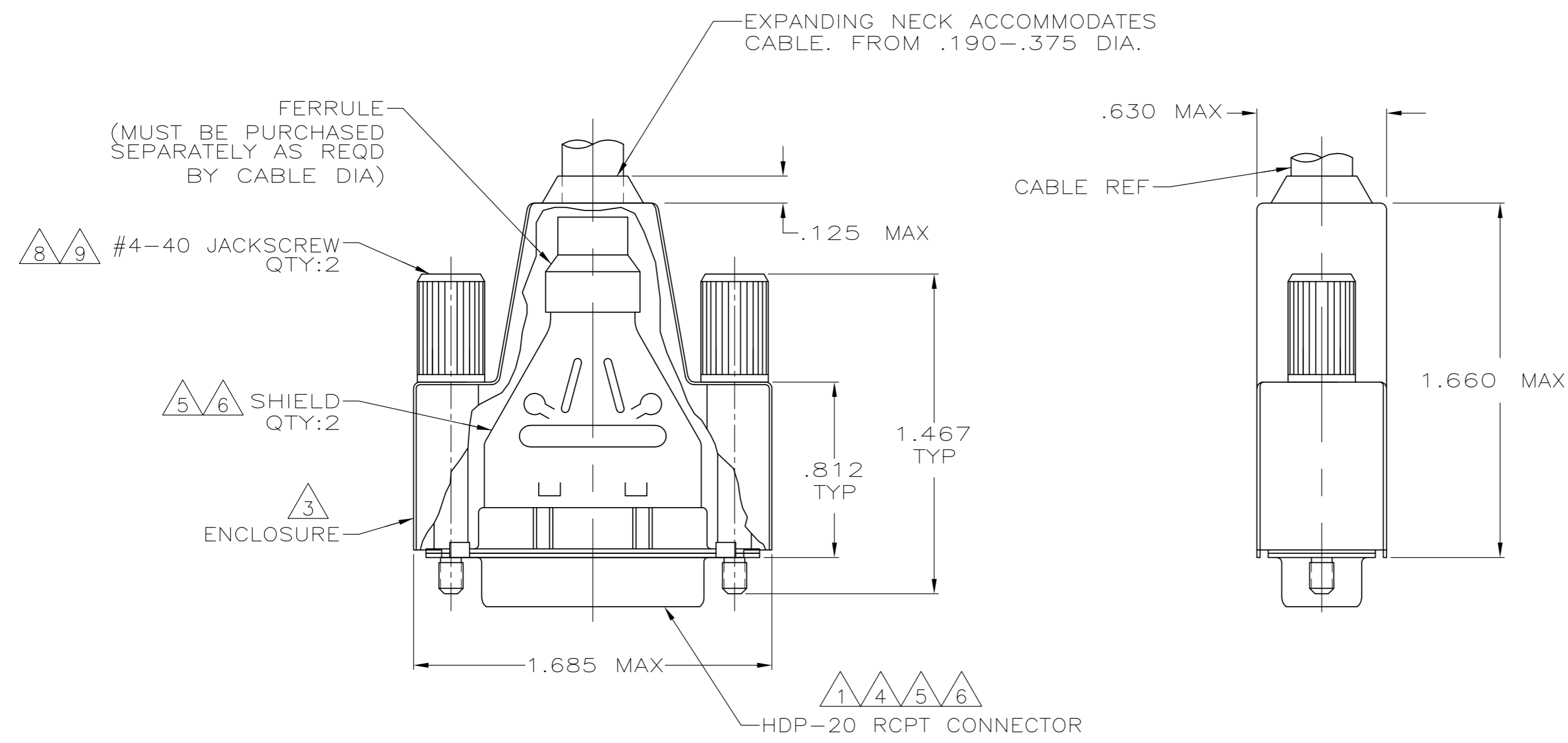

- 1 RCPT ACCEPTS SIZE 20 DF SOCKET CONTACTS. CONTACTS MUST BE PURCHASED SEPARATELY.
- 2 ALL PARTS SHIPPED UNASSEMBLED.
- 3 FLAME RETARDANT 94V-0 RATED, STYRENE POLYOLEFIN OR PVC, BLACK.
- 4 FLAME RETARDANT 94V-0 RATED GLASS FILLED, NYLON OR POLYESTER, BLACK.
- 5 STEEL PER ASTM A109.
- 6 .000200 MIN TIN PLATE OVER .000100 MIN COPPER UNDERPLATE.
- 7 COMPONENTS INDIVIDUALLY BULK PACKED.
- 8 CARBON STEEL, C1022.
- 9 BLACK ZINC FLAKE COATING.

7	W/ LOGOS	1658656-1
PACKAGING	REMARKS	PART NO

THIS DRAWING IS A CONTROLLED DOCUMENT.		DWN J.REITZEL 31JUL03	<b>TE</b> TE Connectivity	
DIMENSIONS: INCHES		CHK S.BOLASH 31JUL03		
TOLERANCES UNLESS OTHERWISE SPECIFIED:		APVD M.WALMSLEY 31JUL03	NAME	
0 PLC ± -		PRODUCT SPEC	BULK KIT, RECEPTACLE, SHIELDING ENCLOSURE, 15 POSN, SIZE 2, AMPLIMITE™ HDP-20	
1 PLC ± -		APPLICATION SPEC	SIZE	CAGE CODE
2 PLC ± -		114-40030	A2	00779
3 PLC ± .020		WEIGHT	DRAWING NO	
4 PLC ± -		0.000000	C=1658656	
4 ANGLES ± -		CUSTOMER DRAWING	SCALE	SHEET
FINISH			2:1	1 of 1
MATERIAL			REV	C
3 4 5 8				
6 9				