

THIS DRAWING IS UNPUBLISHED. RELEASED FOR PUBLICATION 20
 © COPYRIGHT 20 BY - ALL RIGHTS RESERVED.

| REVISIONS | | | | | |
|-----------|-----|---------------|-----------|-----|------|
| P | LTR | DESCRIPTION | DATE | DWN | APVD |
| D | | ECR-18-003276 | 20MAR2018 | KG | DW |
| | | | | | |
| | | | | | |

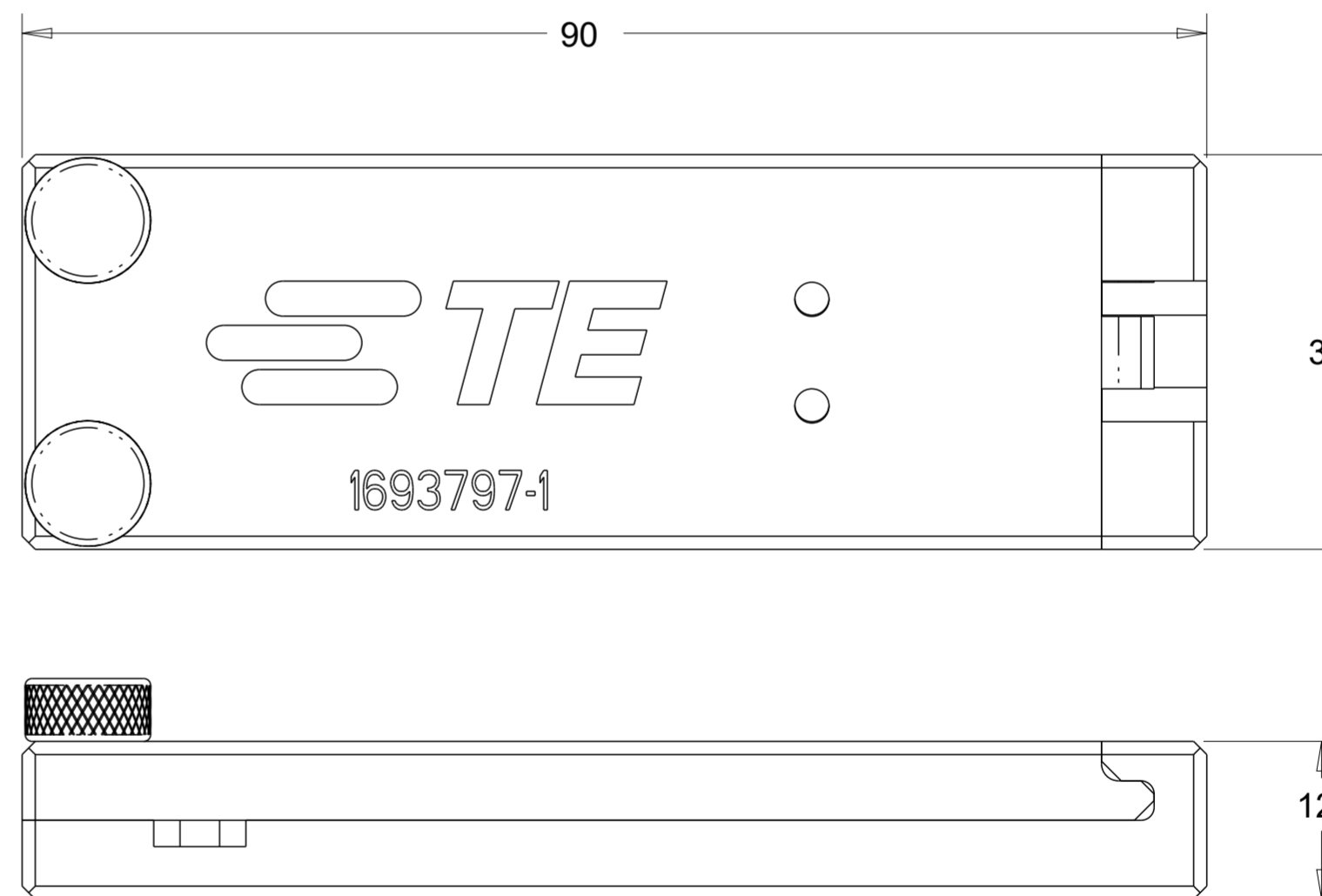
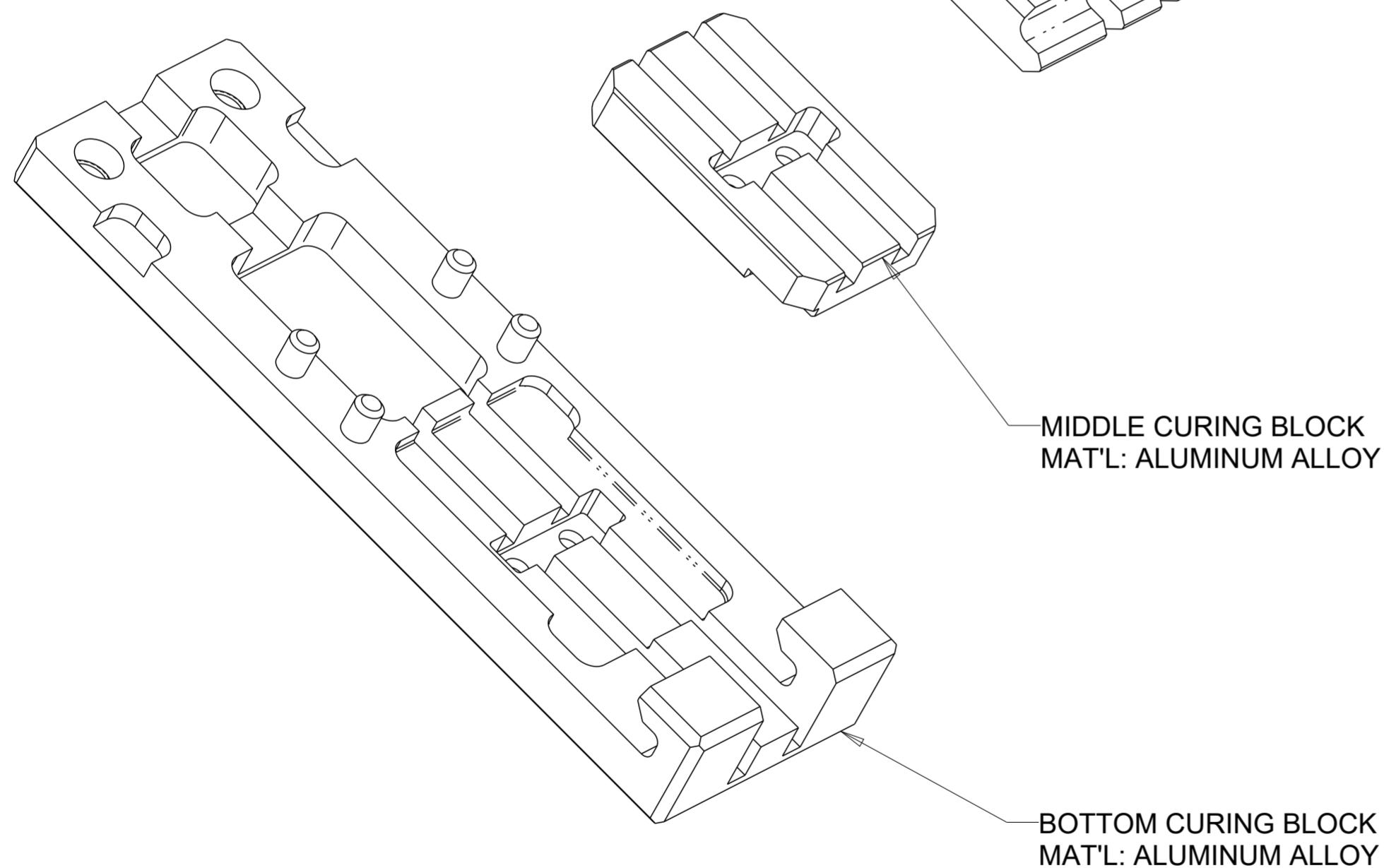
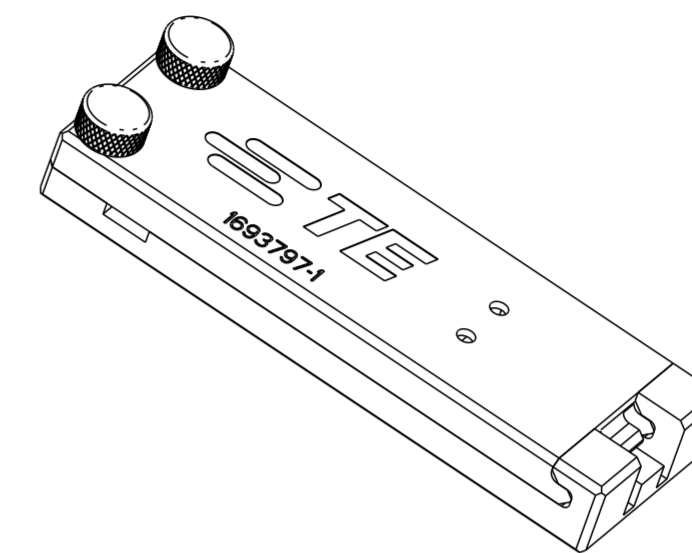
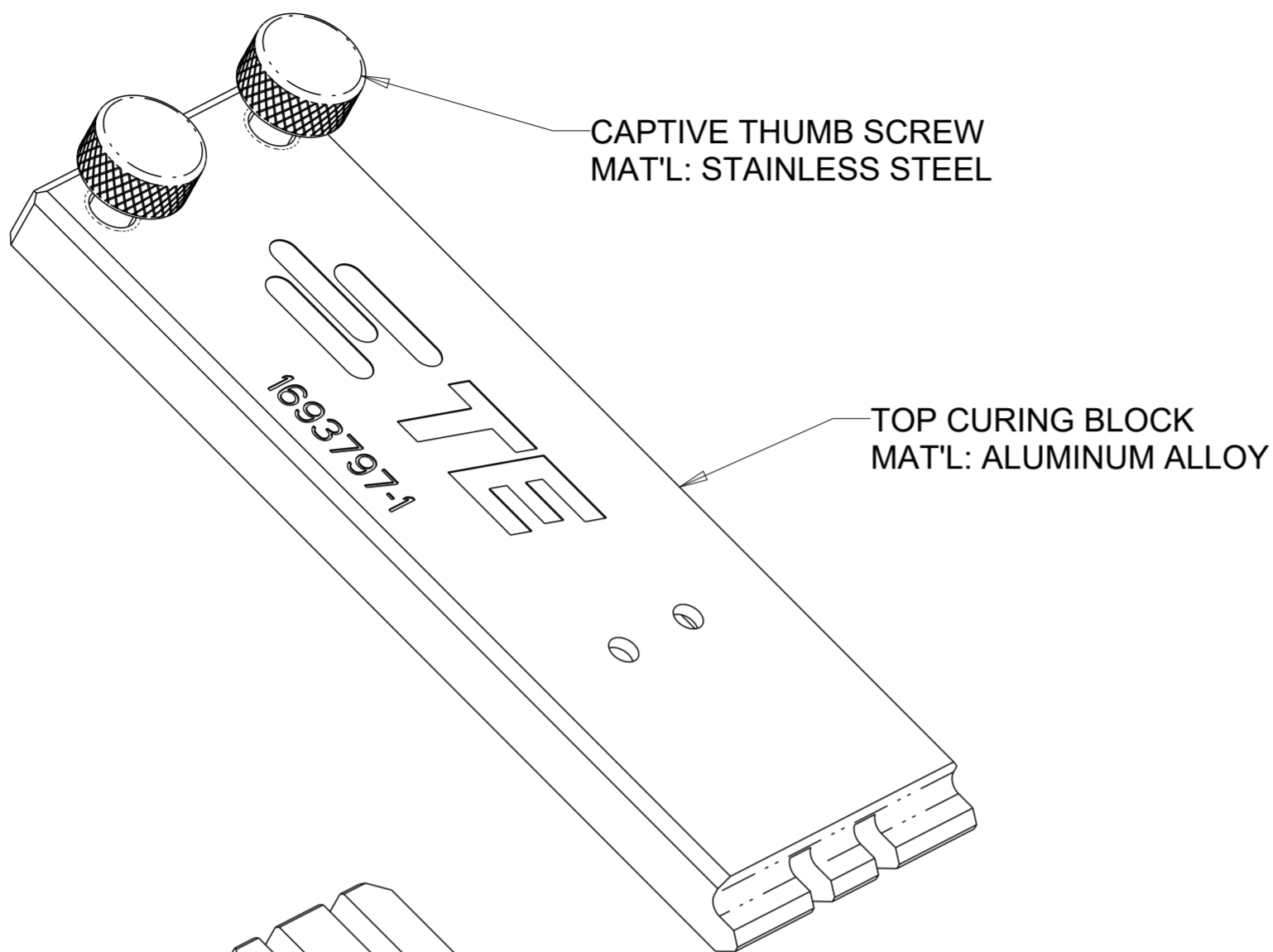

- ALL DIMENSIONS ARE FOR REFERENCE ONLY.
- USE THIS CURING FIXTURE WHEN TERMINATING FERRULES FOR ANY OF THE FOLLOWING CONNECTORS:
 - PRO BEAM JR. PLUG
 - PRO BEAM JR. SEALED BULKHEAD
 - PRO BEAM SR. STANDARD BULKHEAD

1693797-1
PART NUMBER

| | | | | | |
|--|---|----------------------------------|---|--------------------|-----------------------|
| THIS DRAWING IS A CONTROLLED DOCUMENT. | | DWN K.GLATFELTER 22OCT2003 | TE Connectivity | | |
| DIMENSIONS: | | CHK D.WERTMAN 24OCT2003 | | | |
| mm | TOLERANCES UNLESS OTHERWISE SPECIFIED: | APVD D.WERTMAN 24OCT2003 | NAME CURING FIXTURE, PRO BEAM JR., PLUG | | |
| | 0 PLC ± 1 PLC ± 2 PLC ± 3 PLC ± 4 PLC ± ANGLES ± FINISH | PRODUCT SPEC - | SIZE A2 | CAGE CODE 00779 | DRAWING NO 1693797 |
| MATERIAL AS LISTED | HARD ANODIZE (AL ONLY) | APPLICATION SPEC - | RESTRICTED TO | SCALE 2:1 | SHEET 1 OF 1 |
| | | WEIGHT - | CUSTOMER DRAWING | REV D | |