

THIS DRAWING IS UNPUBLISHED. RELEASED FOR PUBLICATION

© COPYRIGHT BY TYCO ELECTRONICS CORPORATION. ALL RIGHTS RESERVED.

LOC	DIST	REVISIONS			
P	LTR	DESCRIPTION	DATE	DWN	APVD
DS		A RELEASED	15/APR/08	IS	HG

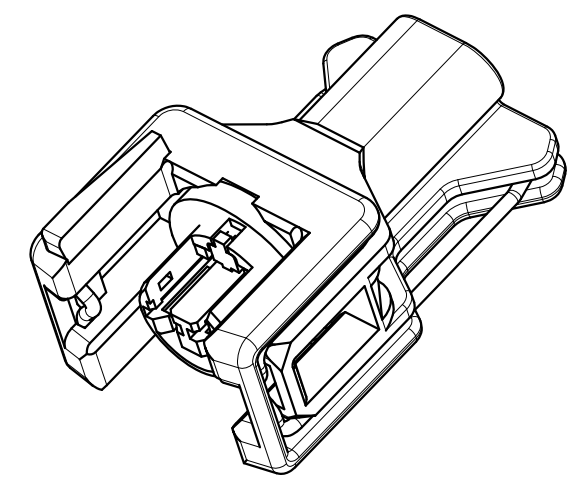
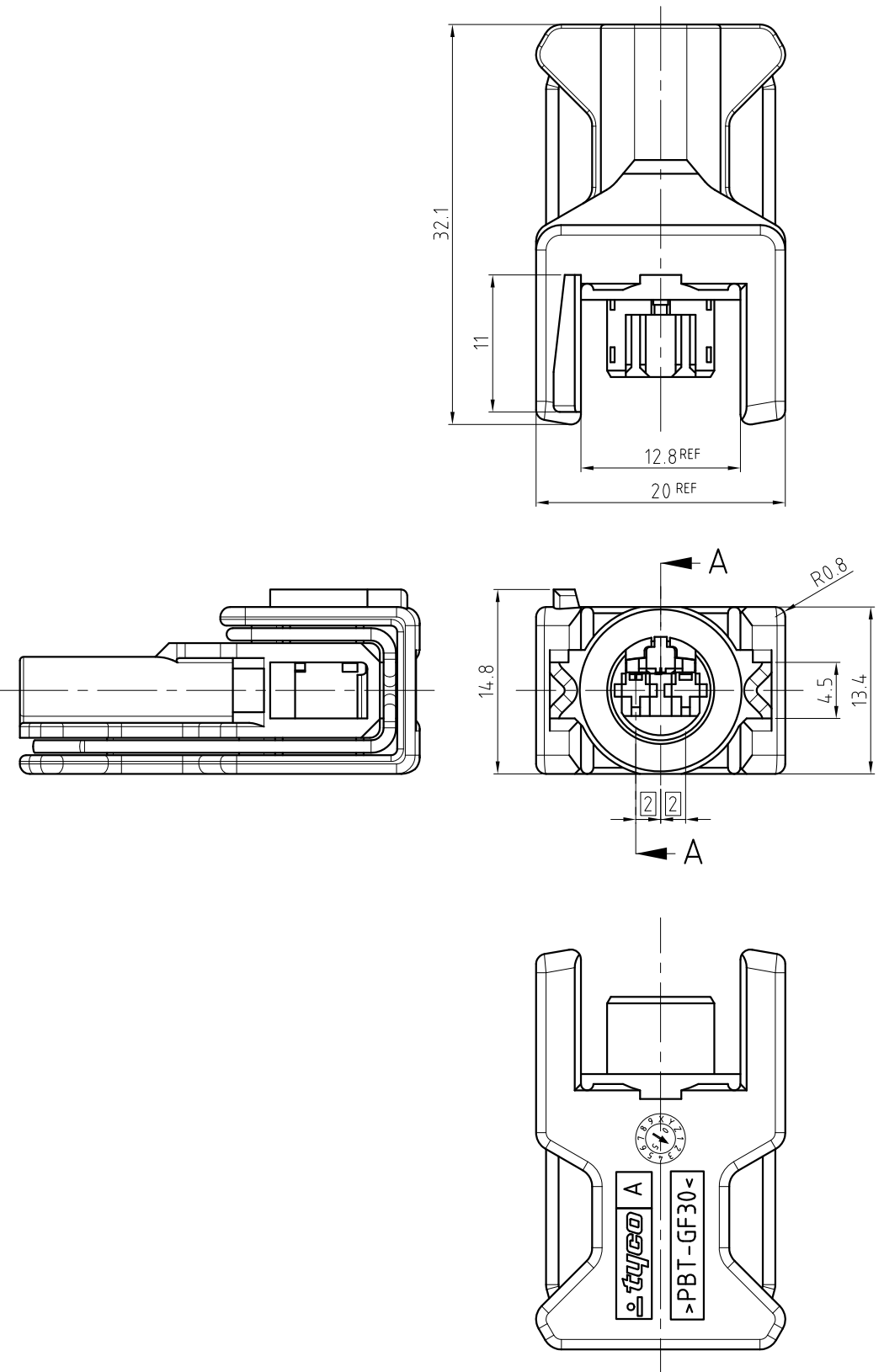

SCALE 2:1

NOTE:
 1. GENERAL TOLERANCE IS ± 0.3 , $\pm 3^\circ$
 2. CONDITION OF DELIVERY : RETAINER PLATE IN OPEN POSITION.
 3. APPLIED RECEPTACLE CONTACT P/N:

	PART No.	WIRE SIZE(mm ²)	FINISH
MTII	0-962875-3	0.25 ~ 0.5mm ²	SEL-GOLD
	0-962876-3	0.5 ~ 1.0mm ²	SEL-GOLD

4. APPLIED WIRE SEAL P/N:

PART No.	WIRE INSULATION	COLOR
0-964971-1	1.2 ~ 1.6mm	RED
0-963530-1	1.4 ~ 1.9mm	GRAY
0-963531-1	CAVITY PLUG	WHITE

	QTY	DESCRIPTION	MATERIAL	COLOR/FINISH
4	1	DULL SPRING	STAINLESS STEEL	
3	1	RED BROWN SEAL	SILICONE	
2	1	YELLOW RETAINER	PBT-GF30	
1	1	GRAY PLUG HSG	PBT-GF30	

0-1743486-3
ASSY P/N

THIS DRAWING IS A CONTROLLED DOCUMENT FOR TYCO ELECTRONICS CORPORATION IT IS SUBJECT TO CHANGE AND THE CONTROLLING ENGINEERING ORGANIZATION SHOULD BE CONTACTED FOR THE LATEST REVISION.		DWN : IS SHIN CHK : YM CHOI APVD : HG CHO PRODUCT SPEC APPLICATION SPEC WEIGHT		AMP KOREA. Kyungsan, Korea NAME MTII INJECTOR 2P PLUG ASS'Y SIZE: A3 CAGE CODE: 00779 DRAWING NO: 1743486 RESTRICTED TO:	
DIMENSIONS: mm 3rd ANGLE PROJECTION	TOLERANCES UNLESS OTHERWISE SPECIFIED: SEE NOTE.	CUSTOMER DRAWING		SCALE 2/1	SHEET 1 OF 1
MATERIAL	FINISH	CUSTOMER DRAWING		REV A	