

THIS DRAWING IS UNPUBLISHED. RELEASED FOR PUBLICATION AUG ,2006.  
 © COPYRIGHT 2009 BY TYCO ELECTRONICS CORPORATION. ALL RIGHTS RESERVED.

LOC		DIST		REVISIONS					
DW		-		P	LTR	DESCRIPTION	DATE	DWN	APVD
				A1		REVISED (ECR-10-016817)	12AUG10	SC	WK

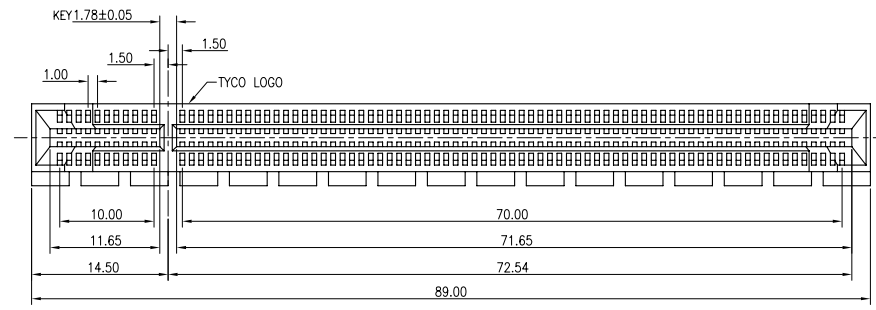

- NOTES:  
 1. MATERIAL:  
 1.1 HOUSING: THERMOPLASTIC,(PA6T), UL94V-0; COLOR:BLACK.  
 1.2 CONTACTS: PHOSPHOR BRONZE  
 2. FINISH:  
 2.1 CONTACT:  
 GOLD PLATING ON CONTACT AREA(SEE TABLE).  
 2.54μm[100μ"]MIN. MATTE TIN PLATING ON SOLDER AREA,  
 1.27μm[50μ"]MIN. NICKEL UNDERPLATING OVERALL.  
 3. WAVE SOLDER CAPABLE TO 265°C  
 PER TE SPEC. 109-202, CONDITION B.

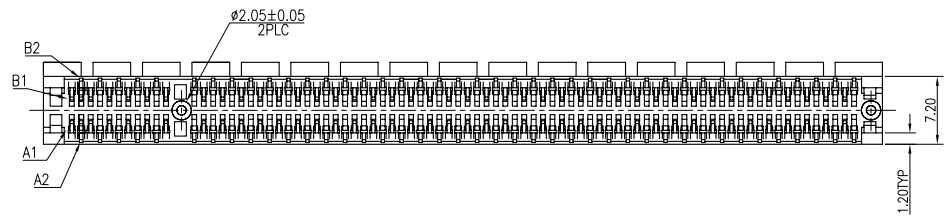
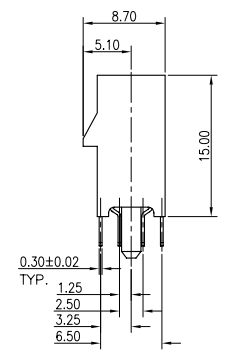
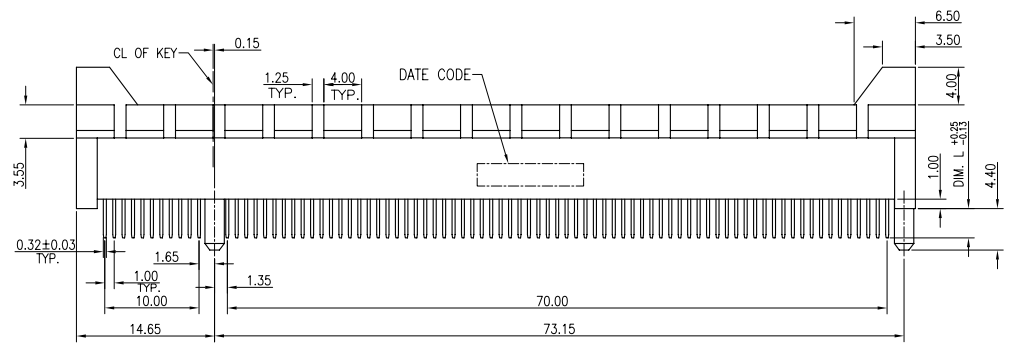

3.10	0.75μm[30μ"]	1-	-3
	0.375μm[15μ"]	1-	-2
2.30	GOLD FLASH	1-	-1
	0.75μm[30μ"]		-3
OBSOLETE 2.30	0.375μm[15μ"]		-2
	GOLD FLASH		1775834-1
DIM. L	MIN. GOLD PLATING	PART NUMBER	

THIS DRAWING IS A CONTROLLED DOCUMENT.		DWN S. HOU 17MAR2006	Tyco Electronics Corporation Taipei, Taiwan	
DIMENSIONS: MM		CHK W.J. KE 17MAR2006		
TOLERANCES UNLESS OTHERWISE SPECIFIED:		APVD W.J. KE 17MAR2006	NAME	
		PRODUCT SPEC	PCI EXPRESS 164P, WITH GUIDING, DIP	
MATERIAL SEE NOTE		APPLICATION SPEC	SIZE	CAGE CODE
		108-57400	501-57432	DRAWING NO
		WEIGHT 8.12 GRAMS	A300779	©=1775834
		CUSTOMER DRAWING	RESTRICTED TO	
		SCALE -	SHEET 1 OF 3	REV A1

4

3

2

1

THIS DRAWING IS UNPUBLISHED. RELEASED FOR PUBLICATION AUG ,2006.  
 © COPYRIGHT 2009 BY TYCO ELECTRONICS CORPORATION. ALL RIGHTS RESERVED.

LOC	DIST	REVISIONS			
P	LTR	DESCRIPTION	DATE	DWN	APVD
DW		SEE SHEET 1.			

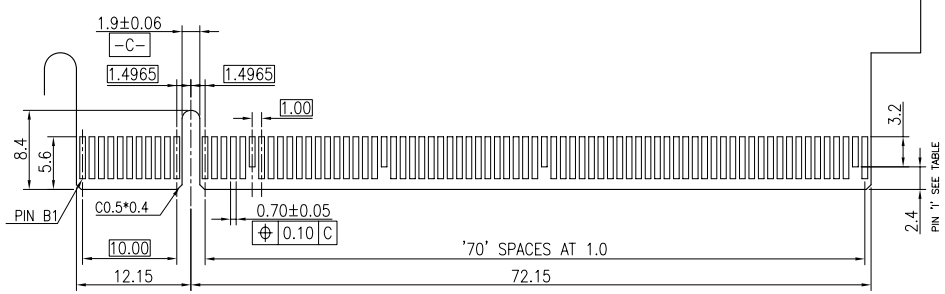

PRIMARY (COMPONENT) SIDE

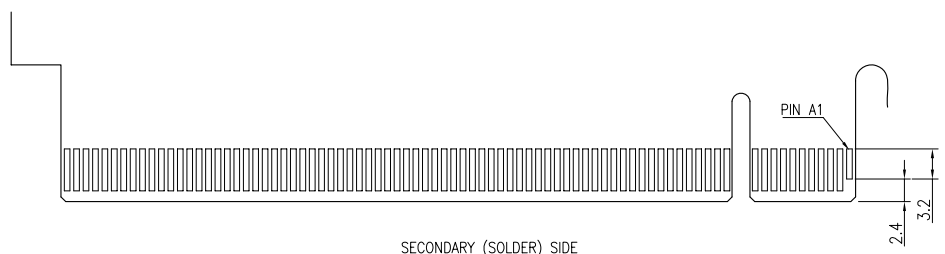

SECONDARY (SOLDER) SIDE

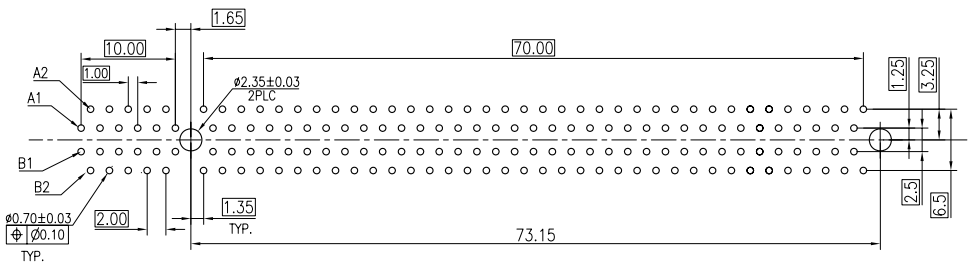

PCB LAYOUT(TOL ±0.05)

"1"  
 B17,B31,B48,B81

THIS DRAWING IS A CONTROLLED DOCUMENT.		DWN		Tyco Electronics Corporation Taipei, Taiwan	
DIMENSIONS: MM		CHK		NAME	
TOLERANCES UNLESS OTHERWISE SPECIFIED:		APVD		PCI EXPRESS 164P, WITH GUIDING, DIP	
0 PLC ± -		PRODUCT SPEC		SIZE	
1 PLC ± 0.3		APPLICATION SPEC		CAGE CODE	
2 PLC ± 0.2		WEIGHT		DRAWING NO	
3 PLC ± -		CUSTOMER DRAWING		A300779	
4 PLC ± -		SCALE		C=1775834	
ANGLES ± 3'		SHEET		RESTRICTED TO	
FINISH		2 OF 3		-	
MATERIAL		REV		A1	

THIS DRAWING IS UNPUBLISHED. RELEASED FOR PUBLICATION AUG ,2006.  
 © COPYRIGHT 2009 BY TYCO ELECTRONICS CORPORATION. ALL RIGHTS RESERVED.

LOC	DIST	REVISIONS					
DW		P	LTR	DESCRIPTION	DATE	DWN	APVD
				SEE SHEET 1.			

- NOTES :
- MATERIAL :
    - 1.1 TRAY : PVC
    - 1.2 SHIPPING CARTON : CORRUGATED FIBERBOARD
  - DIMENSION :
    - 2.1 TRAY : L=333, W=275, H=28.3
    - 2.1 SHIPPING CARTON : L=338, W=285, H=260
  - QUANTITY :
    - 3.1 PRIMARY PACKING: 30 PCS/TRAY
    - 3.2 SECONDARY PACKING: 10 TRAY/CARTON(300PCS)
  - WEIGHT :
    - 4.1 NET WEIGHT : 2.44Kg
    - 4.2 GROSS WEIGHT : 3.36Kg

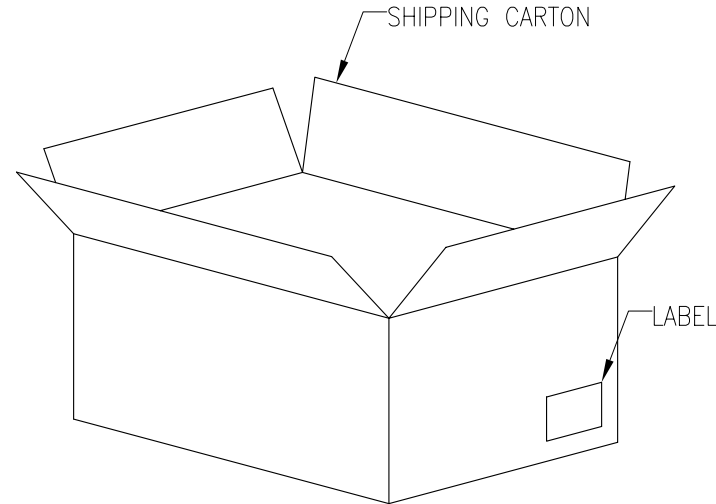
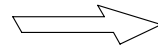
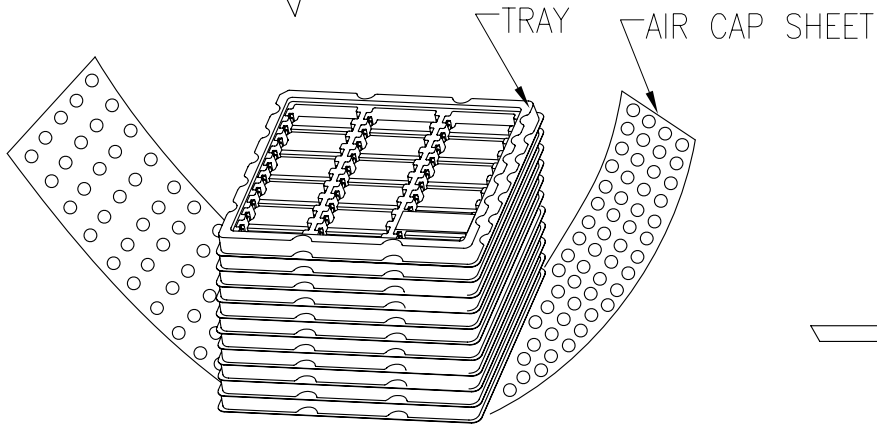
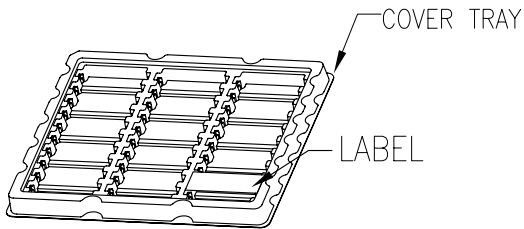
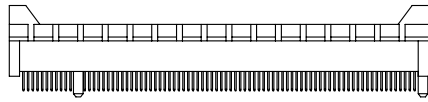

THIS DRAWING IS A CONTROLLED DOCUMENT.		DWN	Tyco Electronics Corporation	
DIMENSIONS: MM		CHK	Taipei, Taiwan	
TOLERANCES UNLESS OTHERWISE SPECIFIED:		APVD	NAME	
0 PLC ± -		PRODUCT SPEC	PCI EXPRESS 164P, WITH GUIDING, DIP	
1 PLC ± -		APPLICATION SPEC	SIZE	CAGE CODE
2 PLC ± -		WEIGHT	A3	00779
3 PLC ± -		CUSTOMER DRAWING	DRAWING NO	
4 PLC ± -		SCALE	C=1775834	
ANGLES ± -		SHEET	3 OF 3	
FINISH		REV	A1	