

THIS DRAWING IS UNPUBLISHED. RELEASED FOR PUBLICATION  
 © COPYRIGHT BY TYCO ELECTRONICS CORPORATION. ALL INTERNATIONAL RIGHTS RESERVED.

LOC	DIST	REVISIONS					
		P	LTR	DESCRIPTION	DATE	DWN	APVD
			A1	ECR-10-009838	26/4/10	NH	KS
			A2	ECR-10-009350	29/4/10	NH	KS
			A3	ECR-10-009739	6/5/10	NH	KS

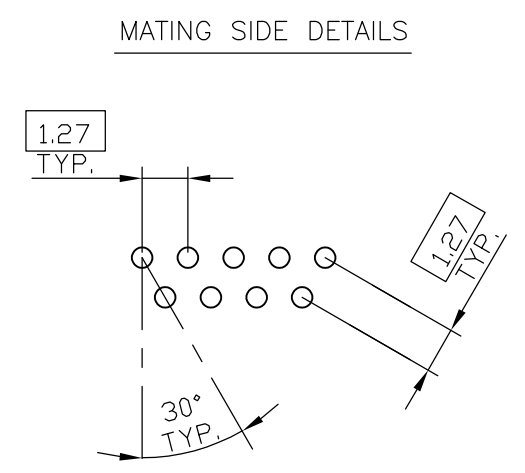
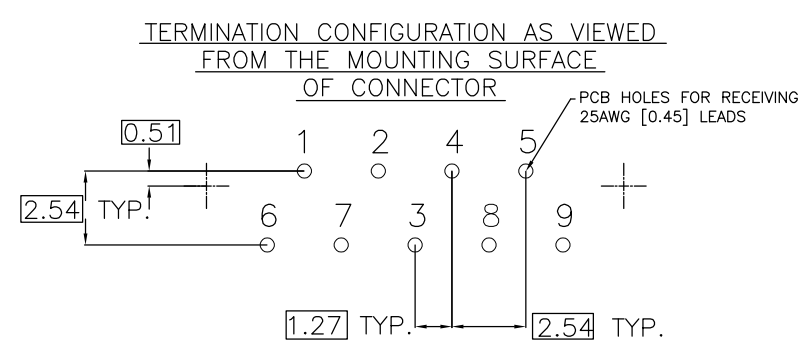
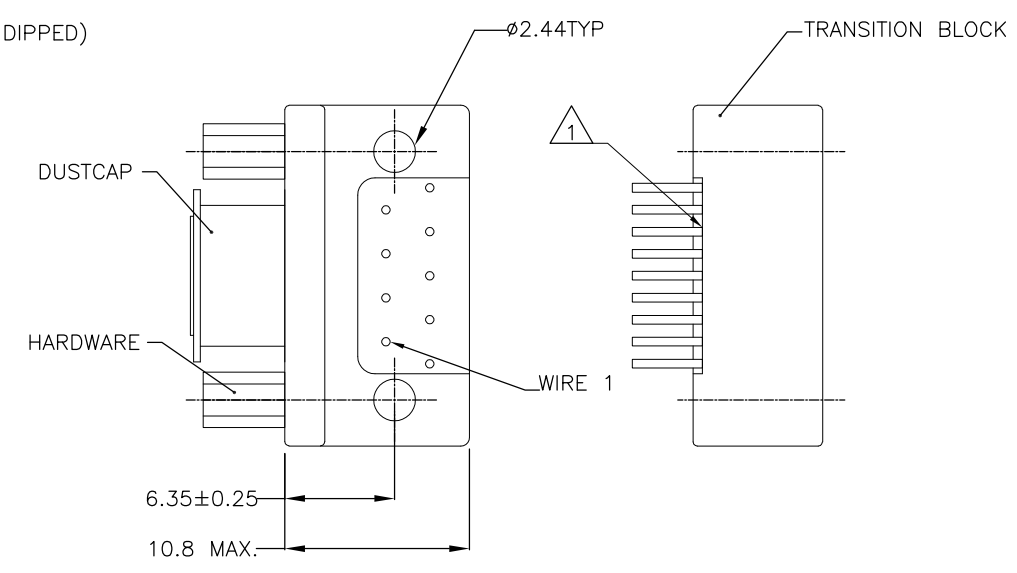
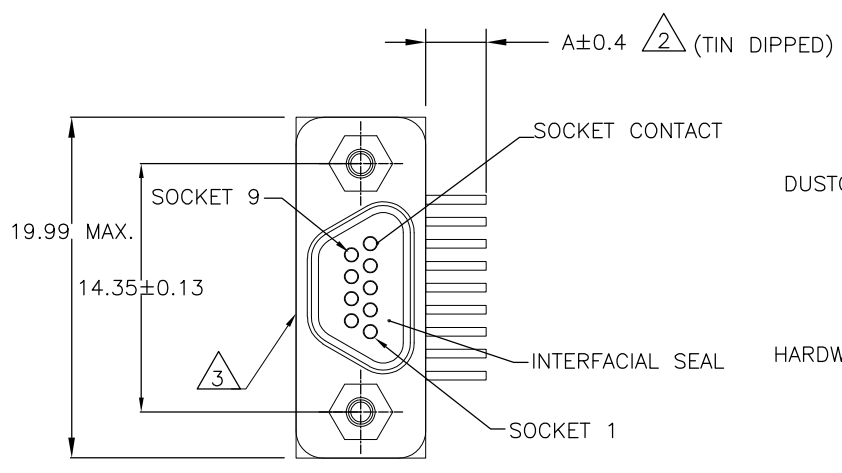
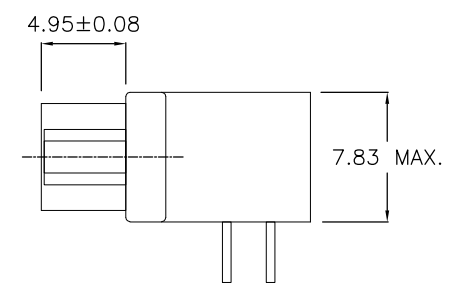

- 1 POTTING LEVEL UP TO HEIGHT AS SHOWN
- 2 WIRES CROPPED TO LENGTH AS SHOWN.
- 3 INMARK TE PN AND DATE CODE YYWW ON CONNECTOR SHELL.
- 4 SPECIFICATION:
  - a. ELECTRICAL:
    - CONTACT RESISTANCE :25 MILLIVOLTS MAX. AT 3 AMPS
    - INSULATION RESISTANCE :5000 MEGAOHMS MIN. @ 500 VDC AT AMBIENT ROOM TEMPERATURE
    - CURRENT RATING :3 AMP MAX. PER CONTACT
  - b. MECHANICAL:
    - CONTACT ENGAGING FORCE :2.22 N MAX. PER CONTACT
    - CONTACT SEPARATION FORCE :0.14 N MIN. PER CONTACT
  - c. ENVIRONMENTAL:
    - OPERATING TEMPERATURE :-55° C TO +125° C
    - VIBRATION CHARACTERISTICS :PER MIL-STD-1344, METHOD 2005, TEST CONDITION IV
- 5 MATERIAL:
  - SHELL :ALUMINIUM ALLOY 6061 T6 GRADE.
  - CONTACT :COPPER ALLOY.
  - BUSHING :STAINLESS STEEL, TYPE 303, PER ASTM-A-582, CONDITION A.
  - HEX NUT :STAINLESS STEEL 300 SERIES NON-MAGNETIC
- 6 FINISH:
  - SHELL :ELECTROLESS NICKEL PLATING PER AMS2404, 25-30 microns THICK.
  - CONTACTS :GOLD PLATED PER MIL-G-45204, TYPE II, CLASS 1.
  - CONTACT TAIL :TIN DIPPED.
  - BUSHING :PASSIVATE PER QQ-P-35
  - HEX NUT :PASSIVATED

2.77	1875846-2	MCK-N1-P-9SRT1
3.56	1875846-1	MCK-N1-P-9SRT1A
<b>A</b>	<b>TE PN</b>	<b>DESCRIPTION</b>

THIS DRAWING IS A CONTROLLED DOCUMENT.		DWN RAJANI B K 20JAN2009	Tyco Electronics Corporation ADM, Bangalore, INDIA	
DIMENSIONS: mm		CHK SHIVAPRAKASH K R 20JAN2009	NAME METAL SHELL-9 SOCKET-90 DEGREE PCB MOUNT	
TOLERANCES UNLESS OTHERWISE SPECIFIED:		APVD KARTHIK S 20JAN2009	PRODUCT SPEC -	
0 PLC ± -		APPLICATION SPEC -		
1 PLC ± -		SIZE A3		
2 PLC ± -		CAGE CODE SDX74		
3 PLC ± -		DRAWING NO C-1875846		
4 PLC ± -		RESTRICTED TO -		
ANGLES ± -		WEIGHT -		
MATERIAL 5		CUSTOMER DRAWING		
FINISH 6		SCALE NTS		
		SHEET 1 OF 1		
		REV A3		