

REVISIONS

P	LTR	DESCRIPTION	DATE	DWN	APVD
	A	RELEASED	10.FEB.'14	YH	HG
	A1	REVISED (ECR-19-000582)	24.JUN.'19	YH	YJ

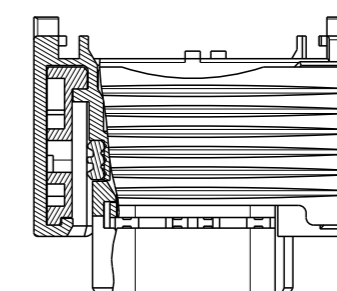
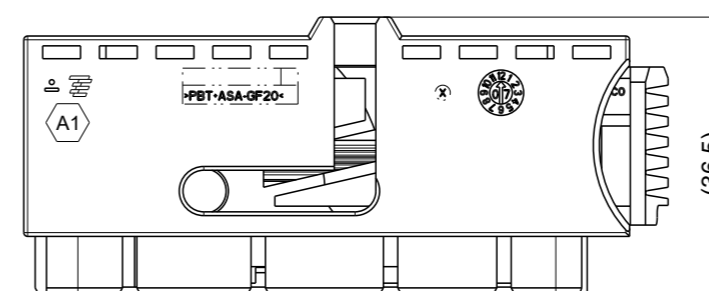
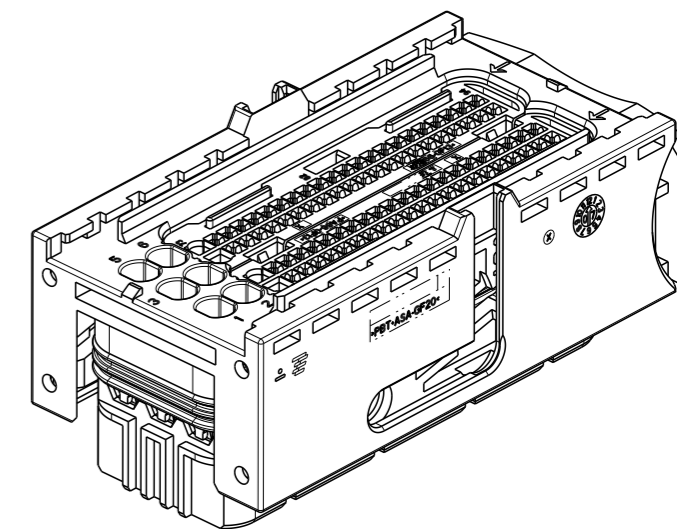
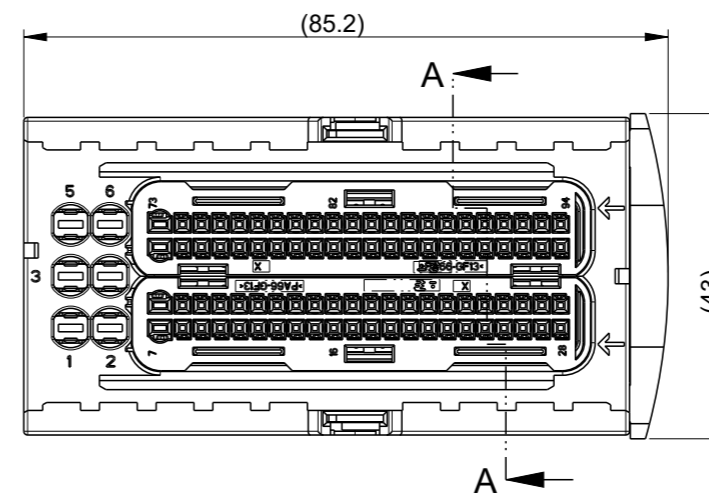
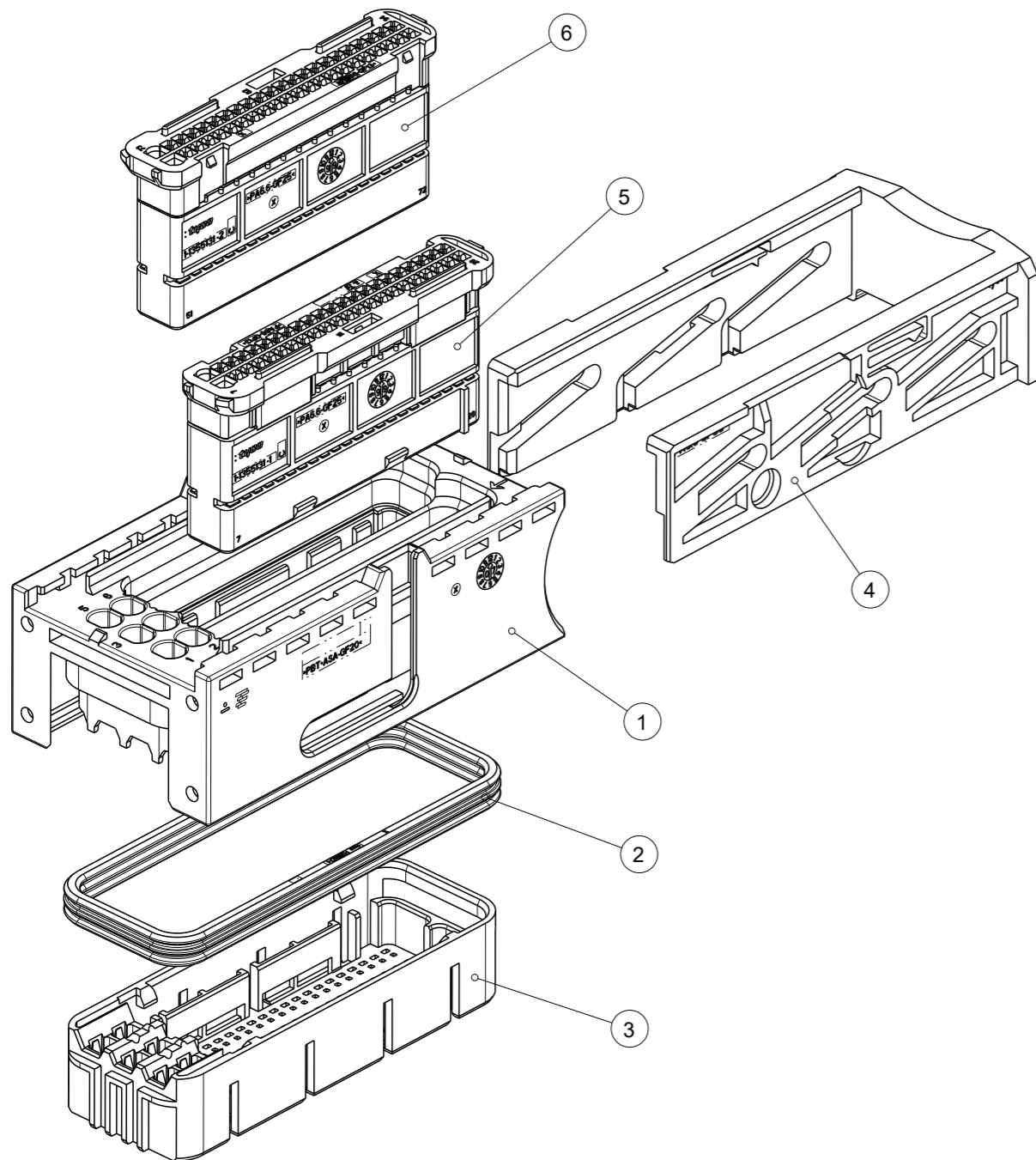

A-A

ASSY P/N	1897356-3
----------	-----------

NO	FINISH/ COLOR	MATERIAL	DESCRIPTION	QTY
6	BROWN	PA66-GF	CONTACT MODUL. COD. B	1
5	BLACK	PA66-GF	CONTACT MODUL. COD. A	1
4	BLACK	PA66-GF33	SLIDE	1
3	BLACK	PBT+ASA-GF20	CAVITY BLOCK	1
2	NATURAL	SILICONE	SEALING	1
1	GRAY	PBT+ASA-GF20	CARRIER HOUSING	1

Notes

- 1. MATING PART EXECUTION ACC. TO 114-18304-001
- 2. SUITABLE CONTACTS: MQS :968220(2005119), 968221(2005120)  
1.5mm CB : 1452158, 1241608  
MCP 2.8K : 1241394, 1241396
- 3. SUITABLE RETAINERS: 1-1355134-1, 1-1355135-1

THIS DRAWING IS A CONTROLLED DOCUMENT.

DIMENSIONS: MM		TOLERANCES UNLESS OTHERWISE SPECIFIED:	
<p>3rd ANGLE PROJECTION</p>		9 PLC	± DECIMALS: ±0.5
		1 PLC	± ANGLES: ±3°
MATERIAL		FINISH	

DWN YH MA
CHK KT LIM
APVD HG CHO
PRODUCT SPEC
APPLICATION SPEC
WEIGHT
CUSTOMER DRAWING



TE Connectivity

NAME			
CARRIER HSG UNSEALED 94POS., ASS'Y			
SIZE	CAGE CODE	DRAWING NO	RESTRICTED TO
A3	00779	C- 1897356	
SCALE 1:1		SHEET 1 OF 1 REV A1	