

LOC		DIST		REVISIONS			
P	LTR	DESCRIPTION		DATE	DWN	APVD	
DS	-	A		RELEASE	09APR'09	SH JK	
		B		REVISED (ECR-10-002760)	16MAR'10	SH JK	

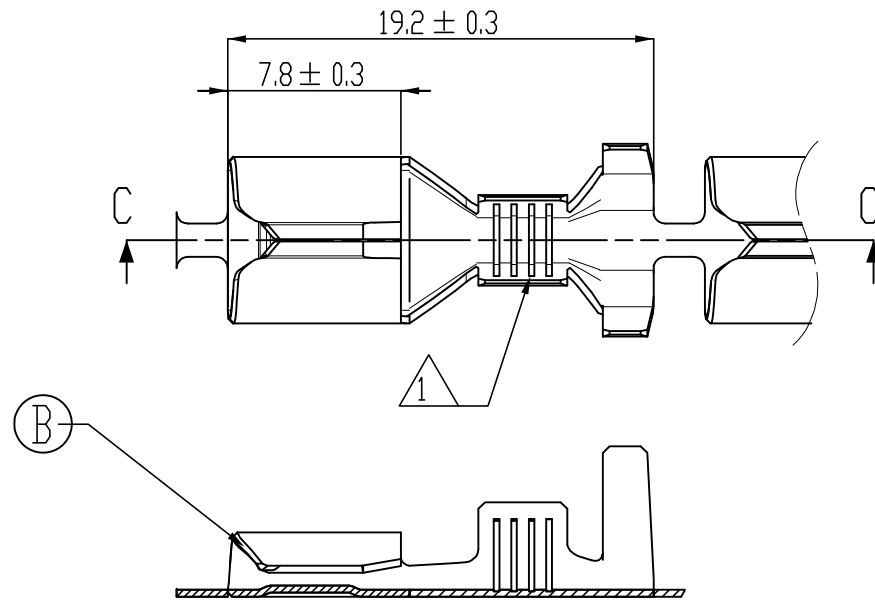

SECTION C-C

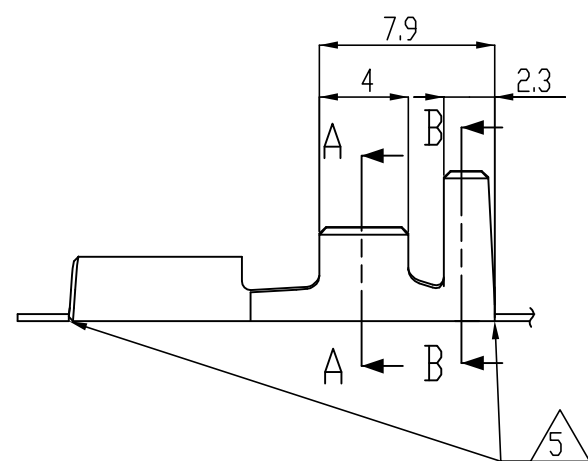
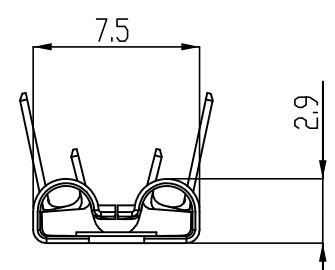

SECTION A-A

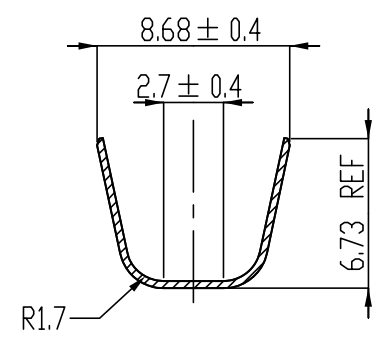

SECTION B-B

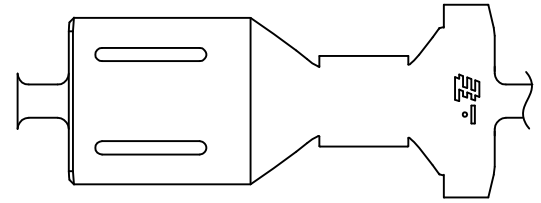

NOTES;

- 1. FOUR SERRATIONS WERE CENTERED IN WIRE BARREL
- 2. WIRE SIZE EQUIV AESSXF 2.0 ~ AEXF 3.0 sqmm
- 3. TOLERANCES UNLESS OTHERWISE SPECIFIED : ±0.2, ±3°
- 4. MUST BE REFERRED TO THE FOLLOWING TABLE 1 FOR CRIMPING OPERATION.
- 5. 0.5 Max Cutoff Tab, with 0.15 Max Burr(Front and Rear)

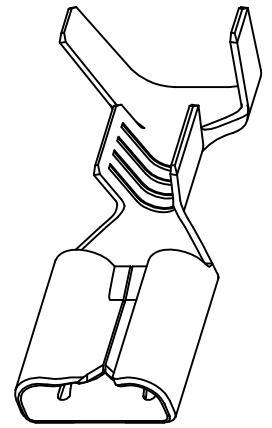

ISD VIEW
SCALE 3:1

THIS DRAWING IS A CONTROLLED DOCUMENT FOR TYCO ELECTRONICS CORPORATION IT IS SUBJECT TO CHANGE AND THE CONTROLLING ENGINEERING ORGANIZATION SHOULD BE CONTACTED FOR THE LATEST REVISION.	
DIMENSIONS: mm	TOLERANCES UNLESS OTHERWISE SPECIFIED: 0 PLC ± 1 PLC ±0.5 2 PLC ±0.13 3 PLC ±0.013 4 PLC ±0.0001 ANGLES ±
MATERIAL -	FINISH -

PRE-TINNED	CuNiSi Alloy 0.32THK	1897661-1
FINISH	MATERIAL	PART NUMBER
DWN SH LEE 31MAR2009	Tyco Electronics Tyco Electronics Kyungsan, Korea.	
CHK KT LIM	NAME	
APVD JK SONG	250 SERIES FASTON RECEPTACLE	
PRODUCT SPEC 108-61108	SIZE A3	CAGE CODE 00779
APPLICATION SPEC 114-61026	DRAWING NO C=1897661	RESTRICTED TO -
WEIGHT	CUSTOMER DRAWING	SCALE 3:1
	SHEET 1 OF 2	REV B

THIS DRAWING IS UNPUBLISHED.

RELEASED FOR PUBLICATION

© COPYRIGHT BY TYCO ELECTRONICS CORPORATION. ALL RIGHTS RESERVED.

LOC

DIST

REVISIONS

DS

P

LTR

DESCRIPTION

DATE

DWN

APVD

TABLE 1

Wire Size(mm ²)	Wire Strip Length	Wire Crimp				Insulation Crimp	
		Width	Height	Form	Area index(%)	Width	Form
TXL 2.0(1.85)	5.3	3.30	1.52 ± 0.03	F	76.03~83.83	7.0	F
FLY,AVSS,AVSSF,AVSSX,AESSXF 2.0(1.9644)							
FLW 2.0(1.987)							
AVS,AEX,AVX 2.0(2.091)			1.67 ± 0.03		78.42~81.98		
AVS 2.5(2.573)							
FLW 3.0(3.134)			1.82 ± 0.03		77.42~82.71		
AEXF,AVS 3.0(3.297)							

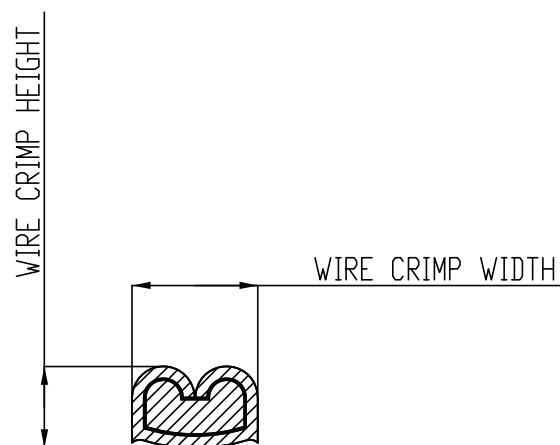

SECTION A-A

<small>THIS DRAWING IS A CONTROLLED DOCUMENT FOR TYCO ELECTRONICS CORPORATION IT IS SUBJECT TO CHANGE AND THE CONTROLLING ENGINEERING ORGANIZATION SHOULD BE CONTACTED FOR THE LATEST REVISION.</small>		DWN	Tyco Electronics Kyungsan, Korea.		
DIMENSIONS:		CHK	NAME		
	TOLERANCES UNLESS OTHERWISE SPECIFIED:	APVD	250 SERIES FASTON RECEPTACLE		
	0 PLC ±	PRODUCT SPEC	SIZE	CAGE CODE	DRAWING NO
	1 PLC ±	APPLICATION SPEC	A3		© 1897661
	2 PLC ±				RESTRICTED TO
	3 PLC ±				
	4 PLC ±				
	ANGLES ±				
MATERIAL	FINISH	WEIGHT	CUSTOMER DRAWING		
			SCALE	SHEET 2 OF 2	REV B