

4

3

2

1

THIS DRAWING IS UNPUBLISHED. RELEASED FOR PUBLICATION  
 © COPYRIGHT - BY TYCO ELECTRONICS CORPORATION. ALL RIGHTS RESERVED.

LOC	DIST	REVISIONS					
		P	LTR	DESCRIPTION	DATE	DWN	APVD
G	14		1	PROPOSED	11JUL2007	MF	MS

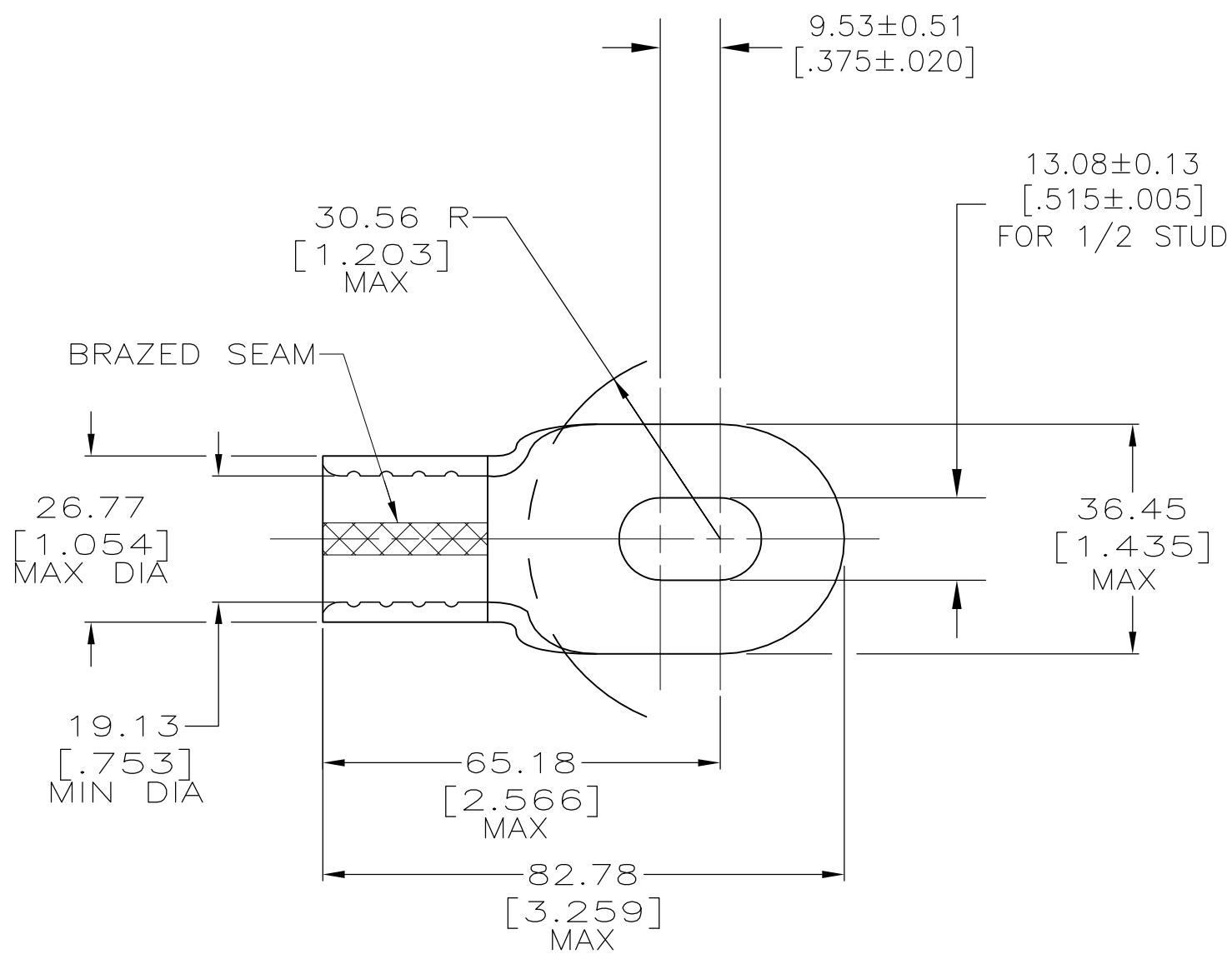

- 1 PRELIMINARY - NOT FOR PRODUCTION.
- 2 MATERIAL THICKNESS: 3.20 [.126].

1 1958145-1  
 PART NUMBER

THIS DRAWING IS A CONTROLLED DOCUMENT.		DWN M.S. FEHER 11JUL2007	Tyco Electronics Corporation Harrisburg, PA 17105-3608																
DIMENSIONS: INCHES		CHK M. SPICER 11JUL2007	NAME TERMINAL, RING TONGUE, SOLISTRAND, WIRE SIZE: 127.0-152.0mm [250 - 300] MCM																
TOLERANCES UNLESS OTHERWISE SPECIFIED:		APVD M. SPICER 11JUL2007	PRODUCT SPEC -																
<table border="0"> <tr><td>0 PLC</td><td>± -</td></tr> <tr><td>1 PLC</td><td>± -</td></tr> <tr><td>2 PLC</td><td>± 0.20[.008]</td></tr> <tr><td>3 PLC</td><td>± -</td></tr> <tr><td>4 PLC</td><td>± -</td></tr> <tr><td>ANGLES</td><td>± -</td></tr> </table>		0 PLC	± -	1 PLC	± -	2 PLC	± 0.20[.008]	3 PLC	± -	4 PLC	± -	ANGLES	± -	APPLICATION SPEC -		SIZE A3	CAGE CODE 00779	DRAWING NO G-1958145	RESTRICTED TO -
0 PLC	± -																		
1 PLC	± -																		
2 PLC	± 0.20[.008]																		
3 PLC	± -																		
4 PLC	± -																		
ANGLES	± -																		
MATERIAL COPPER ASTM B-152 ANNEALED		FINISH 0.00254[.000100] MIN TIN PLATE		WEIGHT -		CUSTOMER DRAWING													
				SCALE 1:1	SHEET 1 OF 1	REV 1													