

creo  
 Creo Parametric 3.0  
 DO NOT REVISE  
 EXCEPT BY CAD

REVISIONS

P	LTR	DESCRIPTION	DATE	DWN	APVD
	A	FIRST ISSUE RSA-18-090-01	20JUN2018	NCL	JMN
	AI	REVISE BY ECN-21-120035	04OCT2021	PSB	DAO
	B	REVISED BY ECN-22-175798	11OCT2022	MJI	RKL

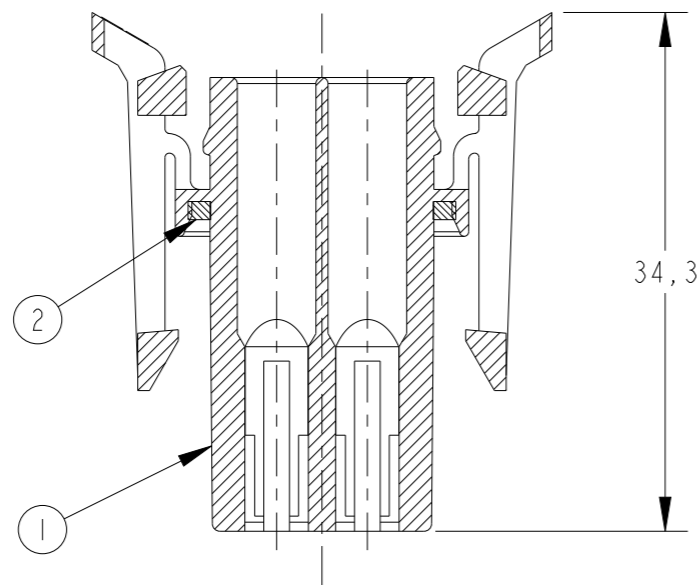
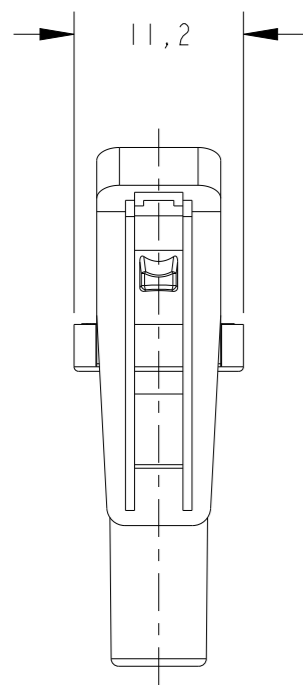
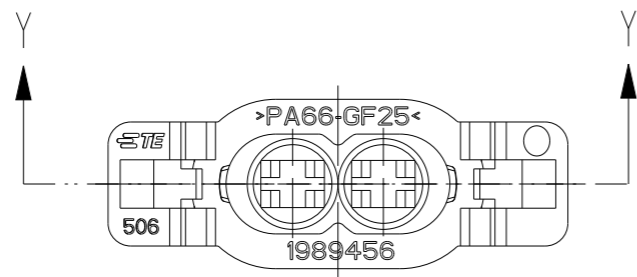

SECTION Y-Y

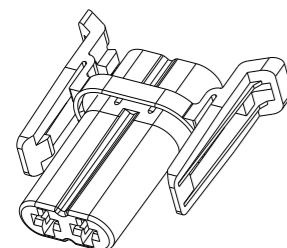
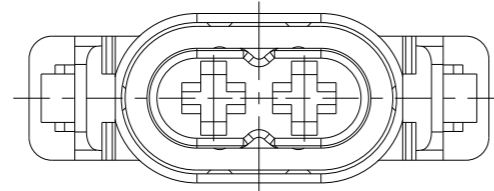
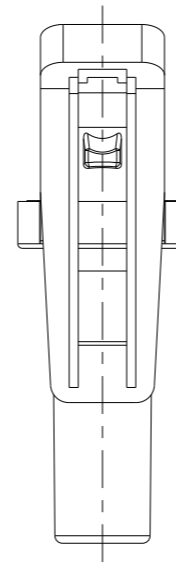
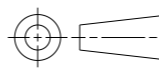

PERSPECTIVE VIEW  
SCALE 1:1

- 1 - CONTRA PEÇA PN 1989440-1
- 2 - PARA A MONTAGEM DO CHICOTE É NECESSÁRIO UTILIZAR CPA 1989455-1
- 1 - COUNTER PART PN 1989440-1
- 2 - FOR HARDNESS ASSEMBLY NEED TO USE CPA 1989455-1

REQ. PER ASSY	ITEM	DESCRIPTION	MATERIAL	FINISH
	1	RUBBER SEAL	SILICONE	LARANJA / ORANGE
	1	HSG., 2 POSN., JPT RCPT	PA 6.6 + 25%GF	PRETO / BLACK
	-1			
1989454				

THIS DRAWING IS A CONTROLLED DOCUMENT.		DWN NCLAPRESA 20JUN2018	 TE Connectivity
DIMENSIONS: mm		CHK ABCAVALLARO 20JUN2018	
		APVD JMNETO 20JUN2018	
TOLERANCES UNLESS OTHERWISE SPECIFIED:		PRODUCT SPEC	
0 PLC ±-		APPLICATION SPEC	NAME HSG 2 POSN JPT ASSY RCPT WIRING HARNESS INJECTOR NOZZLE / ENGINE
1 PLC ±0,3		WEIGHT	SIZE A3
2 PLC ±0,2		CUSTOMER DRAWING	CAGE CODE 00779
3 PLC ±-		SCALE 2:1	DRAWING NO C-1989454
4 PLC ±-		SHEET 1 OF 1	RESTRICTED TO -
ANGLES ±-		REV B	
FINISH			