

© - BY TYCO ELECTRONICS CORPORATION.

REVISIONS

P	LTR	DESCRIPTION	DATE	DWN	APVD
	A	NEW DRAWING	16JUL2020	GK	IR

DIMENSIONS BEFORE APPLICATION

NOTES:

- 1. ISET212005R0000 AS SHOWN.
- 2. MATERIALS:

CONTACT: PHOSPHOR BRONZE, TIN PLATED  
 HOUSING: PC NOT GLASS FILLED  
 COLOUR - CLEAR  
 BUTTONS: PC NOT GLASS FILLED  
 COLOUR - RED AND RED

3 LASER MARKING:

- KEMA
- UL
- TE LOGO
- TE PART NUMBER
- DATE CODE

4 LASER MARKING: IP x5/x7

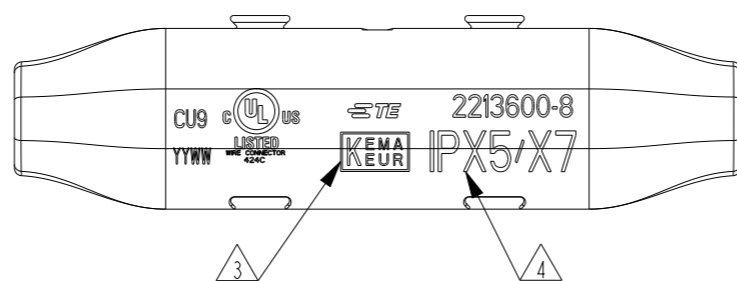
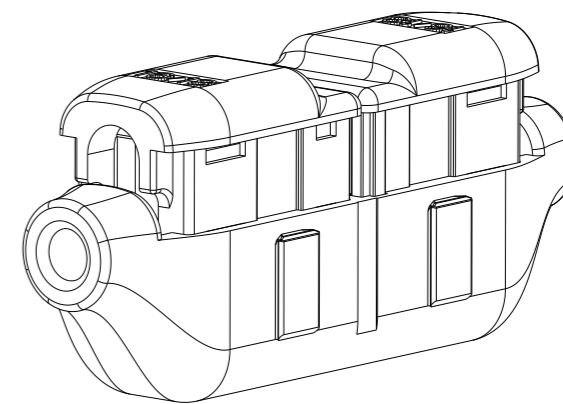
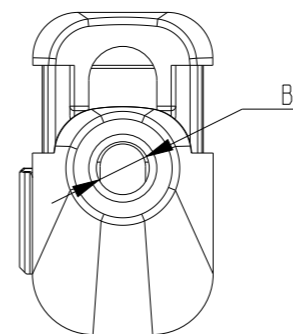
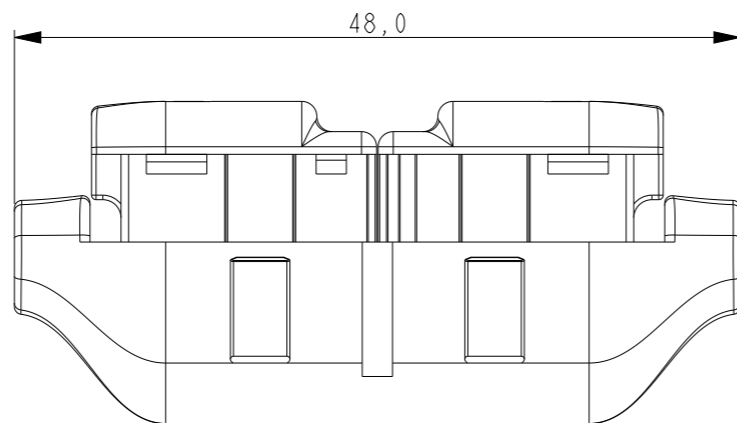
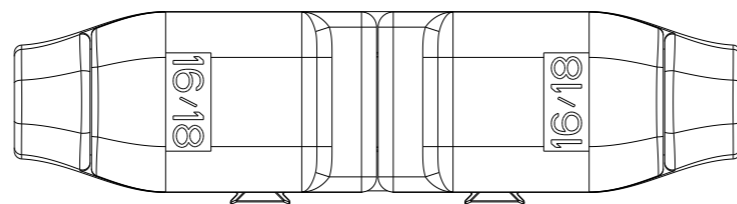
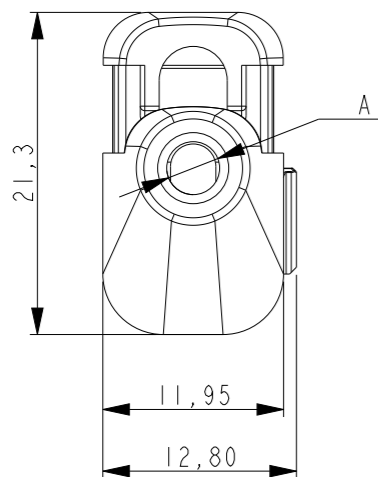

SEALED/4	A=3.5 B=3.5	16/18 TO 16/18	ISET212005R0000	2213600-8
SEALING	WIRE ENTRY	WIRE SIZE	ENTRELEC PN	TE PN
DWN GOPALAKRISHNA HV 16JUL2020	 <b>TE Connectivity</b>			
CHK IAN RIDGEWAY 16JUL2020				
APVD IAN RIDGEWAY 16JUL2020	NAME ISW15-15-L			
PRODUCT SPEC 108-133061	-			
APPLICATION SPEC 114-133061	SIZE A3	CAGE CODE 00779	DRAWING NO ISET212005R0000	RESTRICTED TO -
WEIGHT -	SCALE 2:1			SHEET 1 OF 3
CUSTOMER DRAWING				REV A

THIS DRAWING IS A CONTROLLED DOCUMENT.  
 DIMENSIONING AND TOLERANCING PER ASME Y14.5M-2009.

DIMENSIONS:	TOLERANCES UNLESS OTHERWISE SPECIFIED:
mm	
0 PLC	±-
1 PLC	±0,2
2 PLC	±0,2
3 PLC	±-
4 PLC	±-
ANGLES	±-
MATERIAL	FINISH
-	-
-	-

© - BY TYCO ELECTRONICS CORPORATION.

REVISIONS

P	LTR	DESCRIPTION	DATE	DWN	APVD
-		SEE SHEET 1	-	-	-

DIMENSIONS AFTER APPLICATION

NOTE:  
1. ISET212005R0000 AS SHOWN.

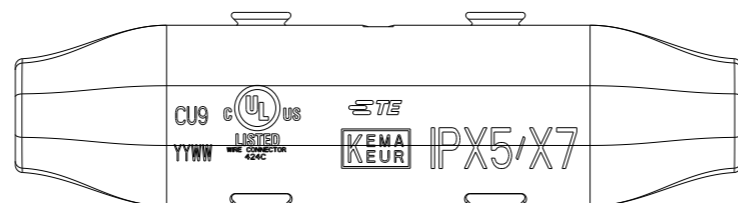
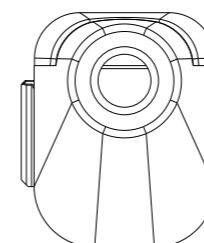
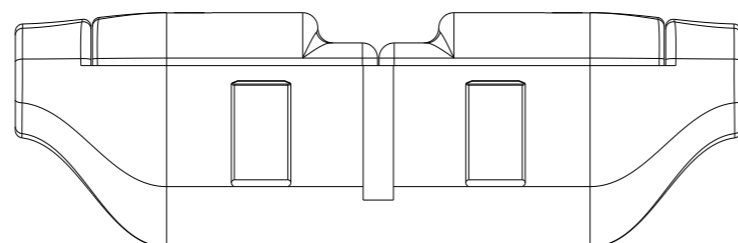
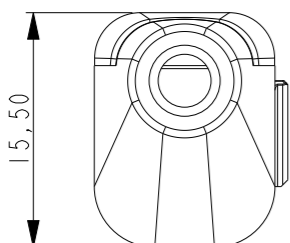
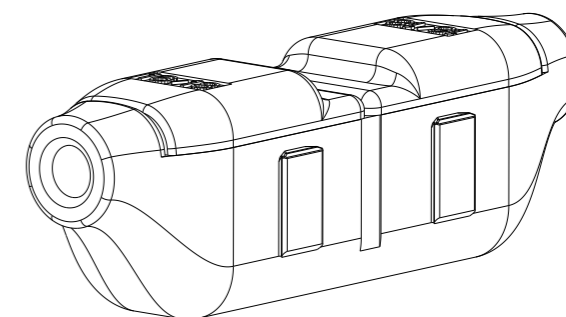
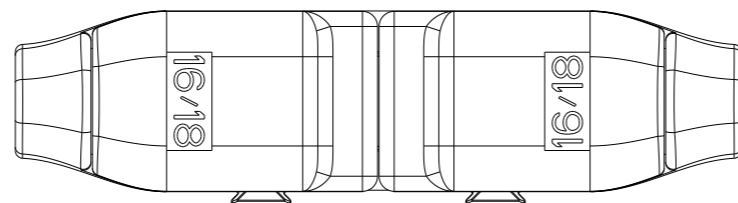

THIS DRAWING IS A CONTROLLED DOCUMENT.		DWN 16 JUL 2020 GOPALAKRISHNA HV	 TE Connectivity		
DIMENSIONS: mm		CHK 16 JUL 2020 IAN RIDGEWAY			NAME ISW15-15-L
TOLERANCES UNLESS OTHERWISE SPECIFIED:		APVD 16 JUL 2020 IAN RIDGEWAY	PRODUCT SPEC 108-133061	RESTRICTED TO	
0 PLC ±- 1 PLC ±0,2 2 PLC ±0,2 3 PLC ±- 4 PLC ±- ANGLES ±-		APPLICATION SPEC 114-133061	SIZE A3	CAGE CODE 00779	
MATERIAL	FINISH	WEIGHT	DRAWING NO G-ISET212005R0000		
-	-	-	SCALE 5:1 SHEET 2 OF 3 REV A		
		CUSTOMER DRAWING			

REVISIONS

P	LTR	DESCRIPTION	DATE	DWN	APVD
-	-	SEE SHEET 1	-	-	-

DIMENSIONS AFTER STACKING

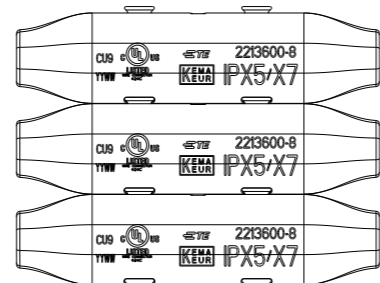
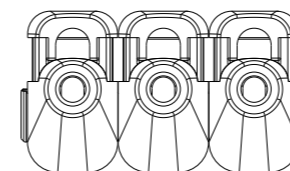
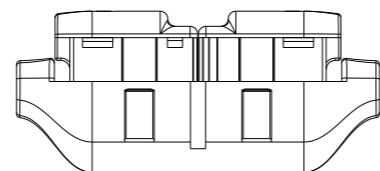
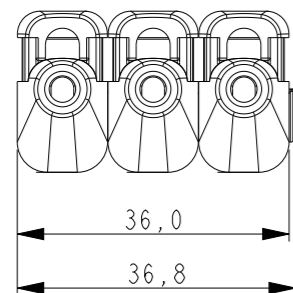
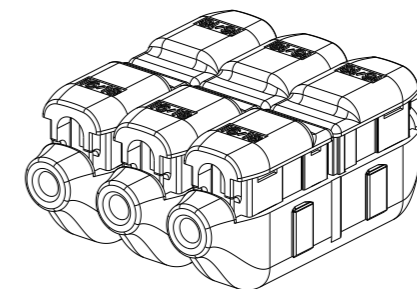
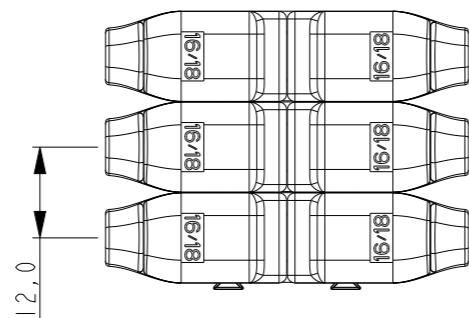

THIS DRAWING IS A CONTROLLED DOCUMENT.

DIMENSIONS: mm	
MATERIAL -	

TOLERANCES UNLESS OTHERWISE SPECIFIED:	
0 PLC	±-
1 PLC	±0,2
2 PLC	±0,2
3 PLC	±-
4 PLC	±-
ANGLES	±-
FINISH	-
	-

DWN	16 JUL 2020
CHK	16 JUL 2020
APVD	16 JUL 2020
PRODUCT SPEC	108-133061
APPLICATION SPEC	114-133061
WEIGHT	-
CUSTOMER DRAWING	

		NAME		RESTRICTED TO
		ISW15-15-L		
SIZE	CAGE CODE	DRAWING NO	-	
A3	00779	©-1SET212005R0000	-	
SCALE		SHEET	OF	REV
5:1		3	3	A