

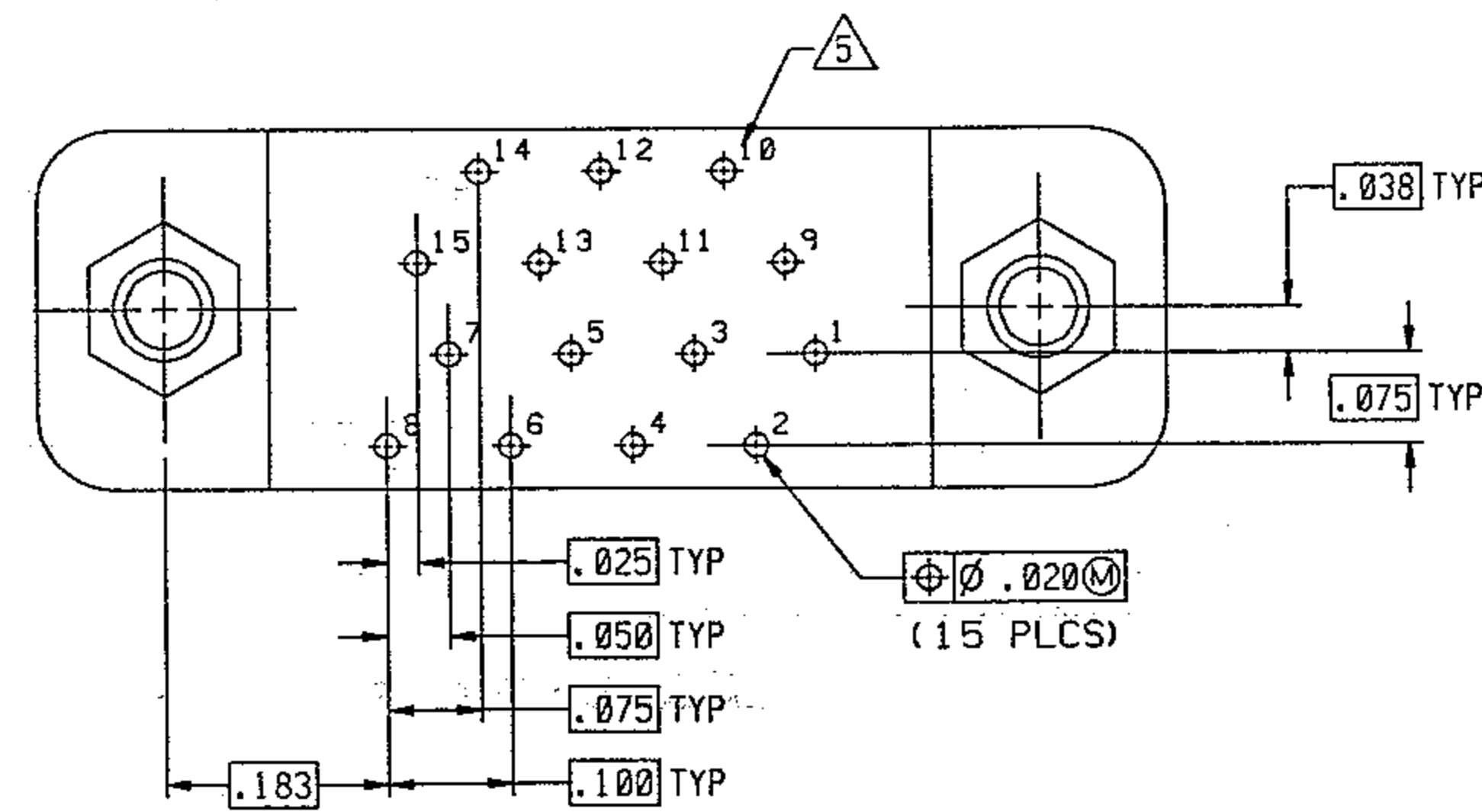

REVISION					
ZONE	LTR	ECN	DESCRIPTION	DATE	APPROVED
	D	38941	UPDATE MKING & EPOXY NOTES	7/27/99	<i>[Signature]</i>
	E		UPDATE PER ECO-10-017486	8/25/10	PJS

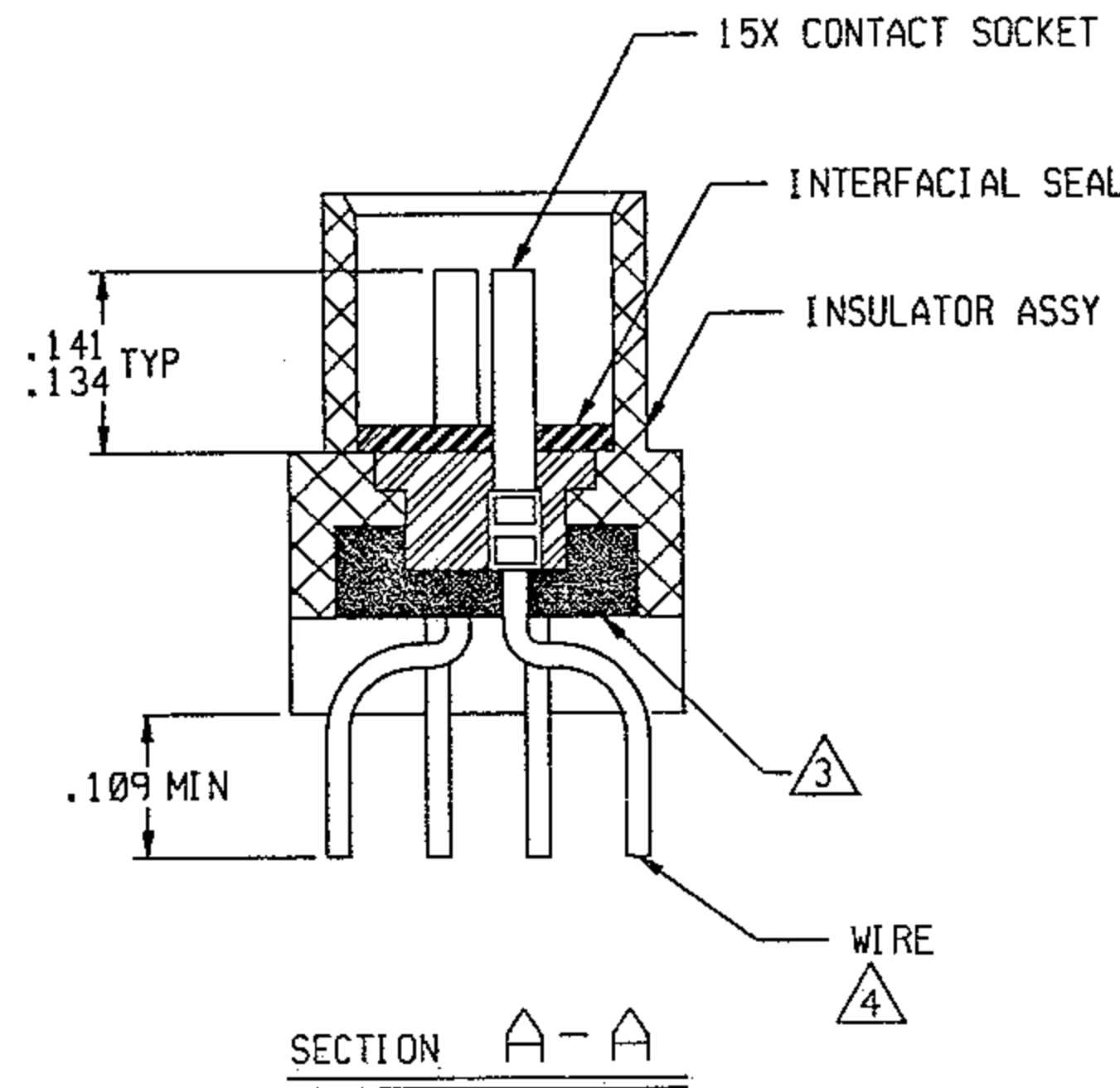
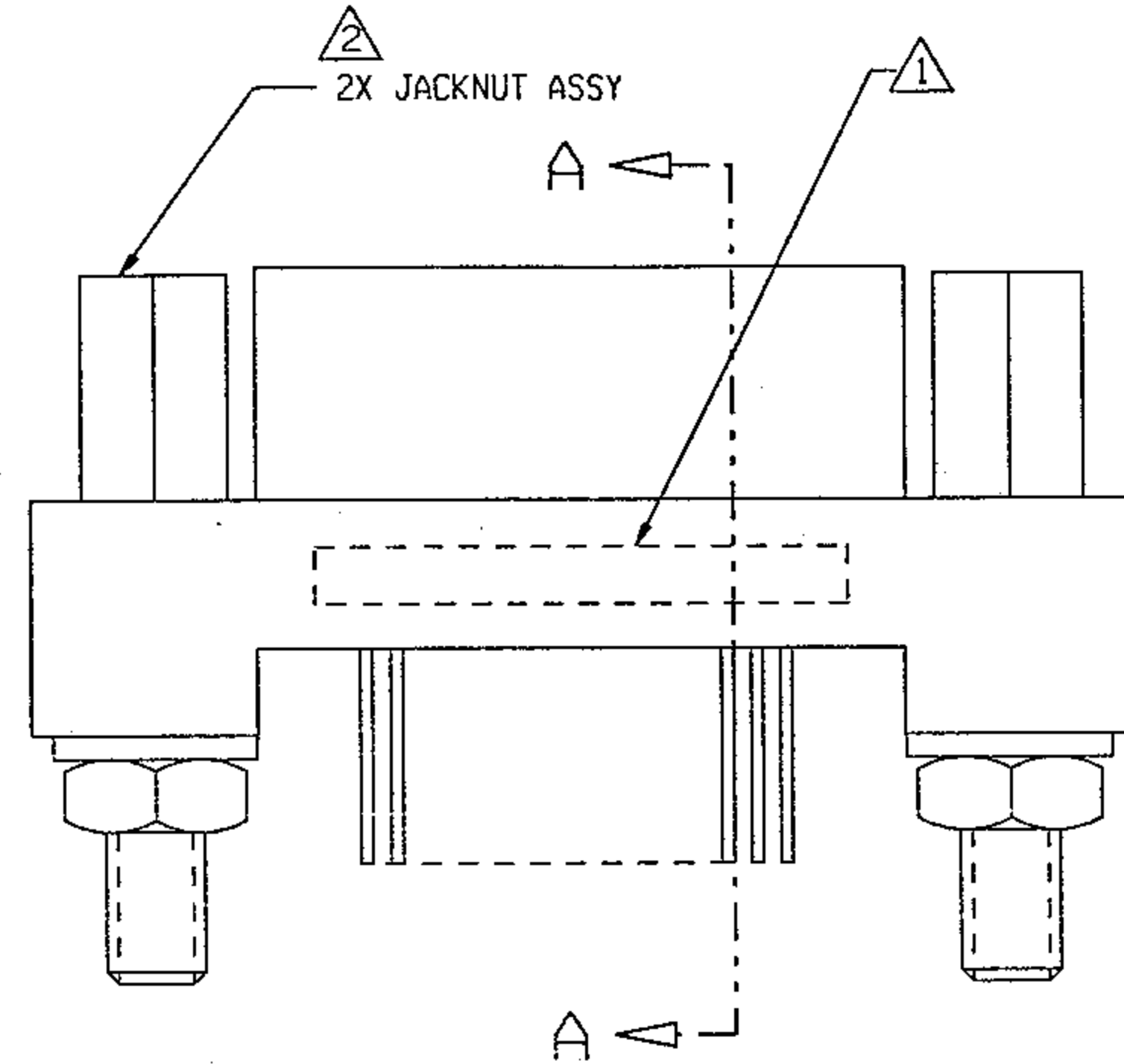
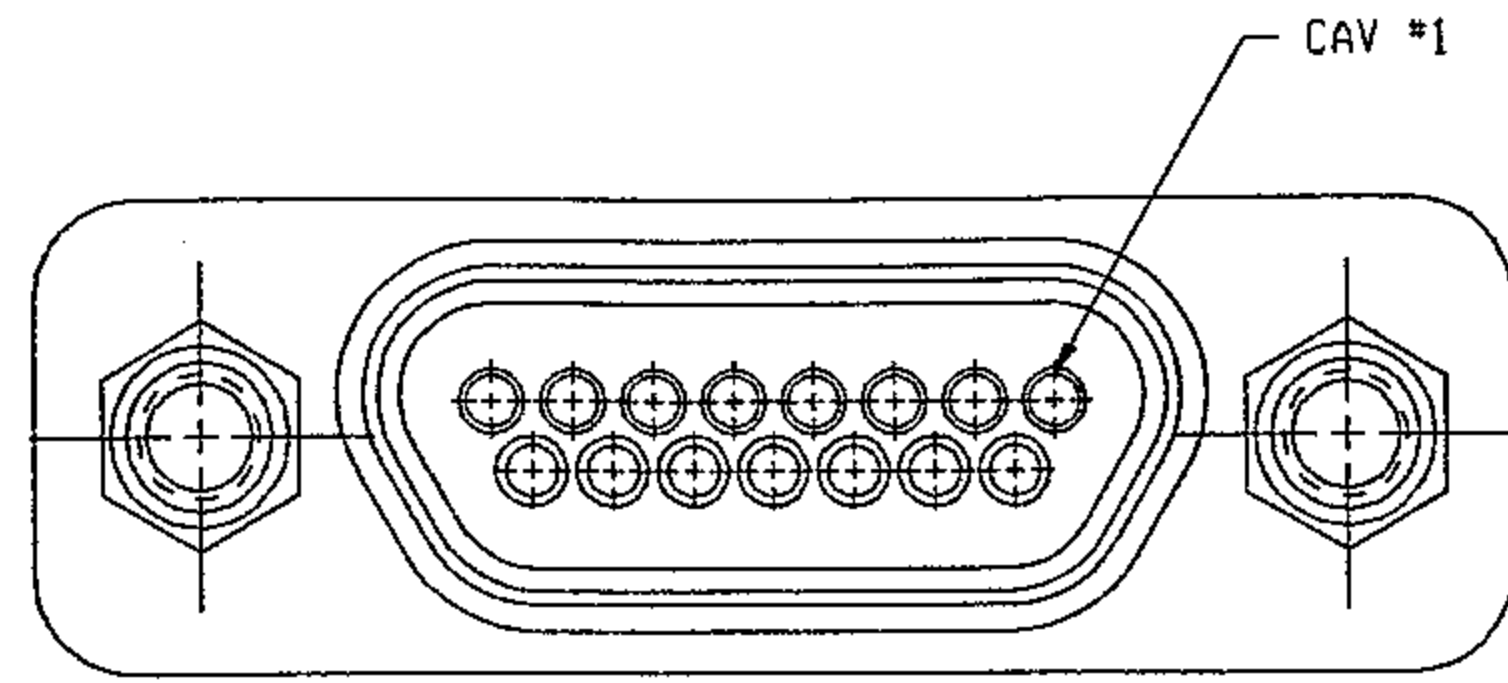

NOTES: UNLESS OTHERWISE SPECIFIED.

- ① MARK PER TPD.
- ② JACKNUT ASSEMBLIES AS SHOWN ARE ASSEMBLED ON FLANGE.
- ③ EPOXY AS SHOWN. WICKING PERMITTED BEYOND POTTING WELL.
- ④ TERMINAL WIRES ARE TO SOLDER DIPPED UP TO MOUNTING SURFACE (MINIMUM).
- ⑤ LEAD IDENTIFICATIONS AS SHOWN ARE REFERENCE ONLY. DO NOT APPEAR ON THE PART.
- 6. CRIMP LEADS INTO CONTACTS PER MEP302-05.

UNLESS OTHERWISE SPECIFIED DIMENSIONS ARE IN INCHES. TOLERANCE ARE: FRACTIONS DECIMALS ANGLES ± 1/8 .XX ± .01 ± 2° .XXX ± .005	APPROVALS		 MICRODOT CONNECTORS A DIVISION OF UNI-STAR INDUSTRIES INC. 306 PASADENA AVE., SO. PASADENA, CA 91030	PROD CODE 845 CODE M
	SIGNATURE	DATE		
MATERIAL:	CHECKED	PRO. ENG.	SIZE	CODE IDENT NO.
FINISH:	APPROVED	APPROVED	B	98278
THIS DOCUMENT IS THE PROPERTY OF MICRODOT CONNECTORS, A DIVISION OF UNI-STAR INDUSTRIES INC. USE OF THIS DOCUMENT OR ANY PART THEREOF IS STRICTLY FORBIDDEN WITHOUT THE EXPRESS WRITTEN PERMISSION OF MICRODOT CONNECTORS, A DIVISION OF UNI-STAR INDUSTRIES INC.			DRAWING NO.	2-1532012-1
			SCALE: 4X	SHEET 1 OF 1

4

3

2

1