

### VCS Series Part Number Tree

VCS -  -

### CABLE OPTION

0 or 2 0.16M Single Insulated PVC  
1, 3, 7 or 9 0.6M Single Insulated PVC

### MATERIAL

x1 or x2 Polypropylene / Float Foamed Polypropylene 30mm (Internal fit only)  
x3 or x4 Polypropylene / Float Hollow Polypropylene  
x5 or x6 Nylon / Float Hollow Nylon  
x7 or x8 Kynar / Float Hollow Polyphenylene Sulfide (PPS)

### SWITCH

Cable Option 2x or 3x SPST MAX 100 VDC, 250VRMS, 1AMP, 50 WATT

### FITTING OPTION

M 8 X 1.25mm (Even Part Number)

### SEALING MATERIAL

Nitrile (M8 fitting only)

<b>Unless otherwise specified tolerances are</b>	
<b>Cable Lengths</b>	
Cable Lengths	Tolerance
100 - 200 mm	+/-5
500 mm	+/-10
1000 mm	+/-20
2000 mm	+/-50
5000 mm	+/-100
<b>General Tolerances</b>	
Dimension	Tolerances
<20 mm	+/-0.25
20 - 50 mm	+/-0.50
50 - 100 mm	+/-0.75
100 - 150 mm	+/-1.00
Angles	+/-0.5 Deg

SERIES	TCPN
VCS-02	20017616-02
VCS-06	20017616-06

**NOT ALL OPTIONS AVAILABLE**

ZONE	REV	DESCRIPTION	DATE	APPROVER
C5	A1	CHANGE PER ECN-22-153178	10/05/2022	RC
	A	INITIAL RELEASE	06/10/2020	JP
REVISIONS				

DIMENSIONS: mm	TOLERANCES UNLESS OTHERWISE SPECIFIED:
	0 PLC - 1 PLC +0.5 2 PLC +0.13 3 PLC +0.013 4 PLC +0.0001
ANGLES ±	
SURFACE TEXTURE	

DWN	L Hernandez	MATERIAL	WEIGHT	kg					
CHK	R Cooper		TE Connectivity						
APVD	J Pendleton								
NAME	VCS M8 TOP LEVEL CATALOG DWG								
SCALE	1:1	SIZE	A3	DRAWING NO	20017616-00	SHEET	1 OF 2	REV	A1

THIS INFORMATION IS CONFIDENTIAL AND PROPRIETARY TO TYCO ELECTRONICS CORPORATION AND ITS WORLDWIDE SUBSIDIARIES AND AFFILIATES (TE). IT MAY NOT BE DISCLOSED TO ANYONE, OTHER THAN TE PERSONNEL, WITHOUT AUTHORIZATION FROM TE (www.TE.com).

USED ON

DWG NO 20017606-00

THIS DRAWING IS A CONTROLLED DOCUMENT

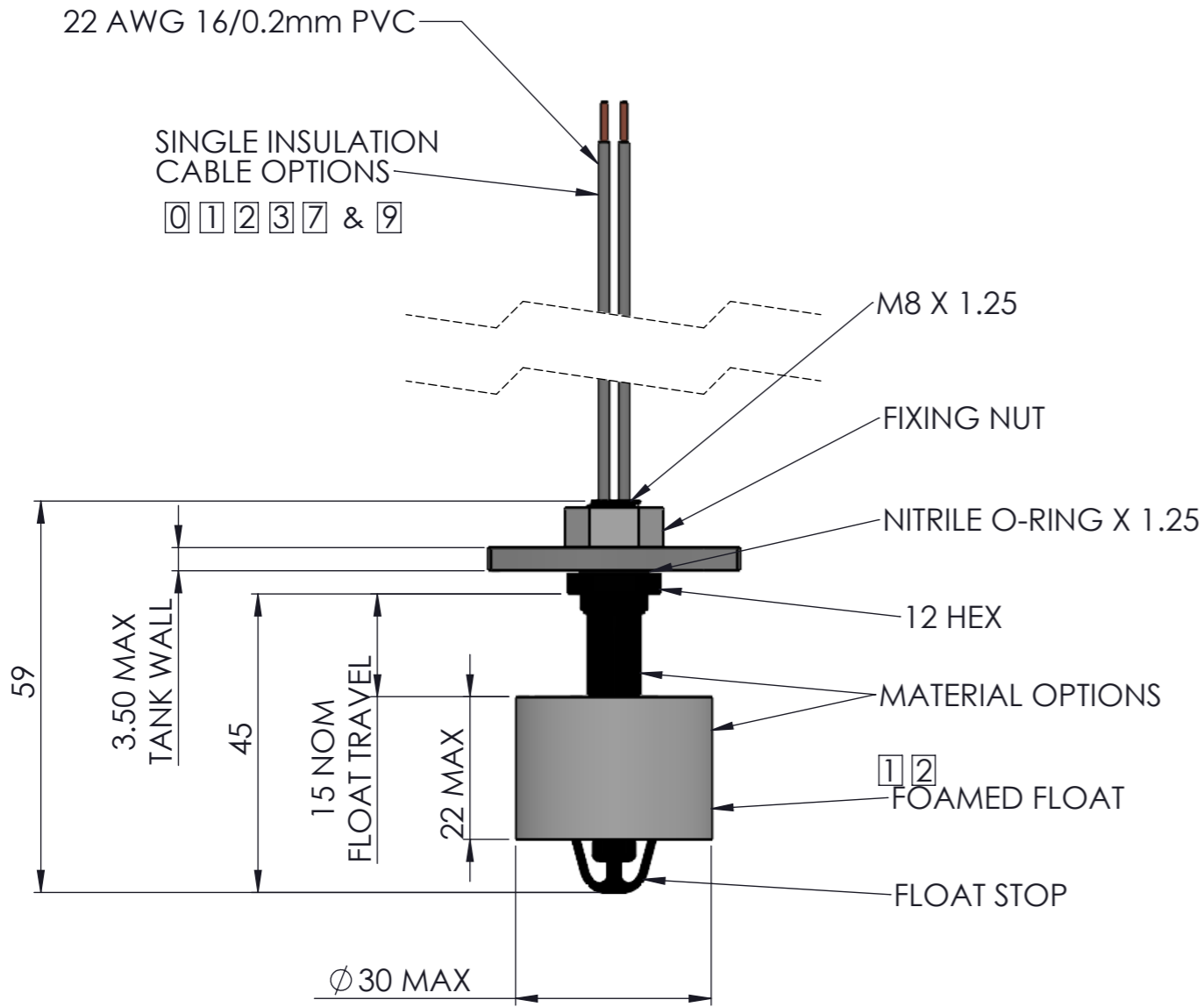

VCS-02

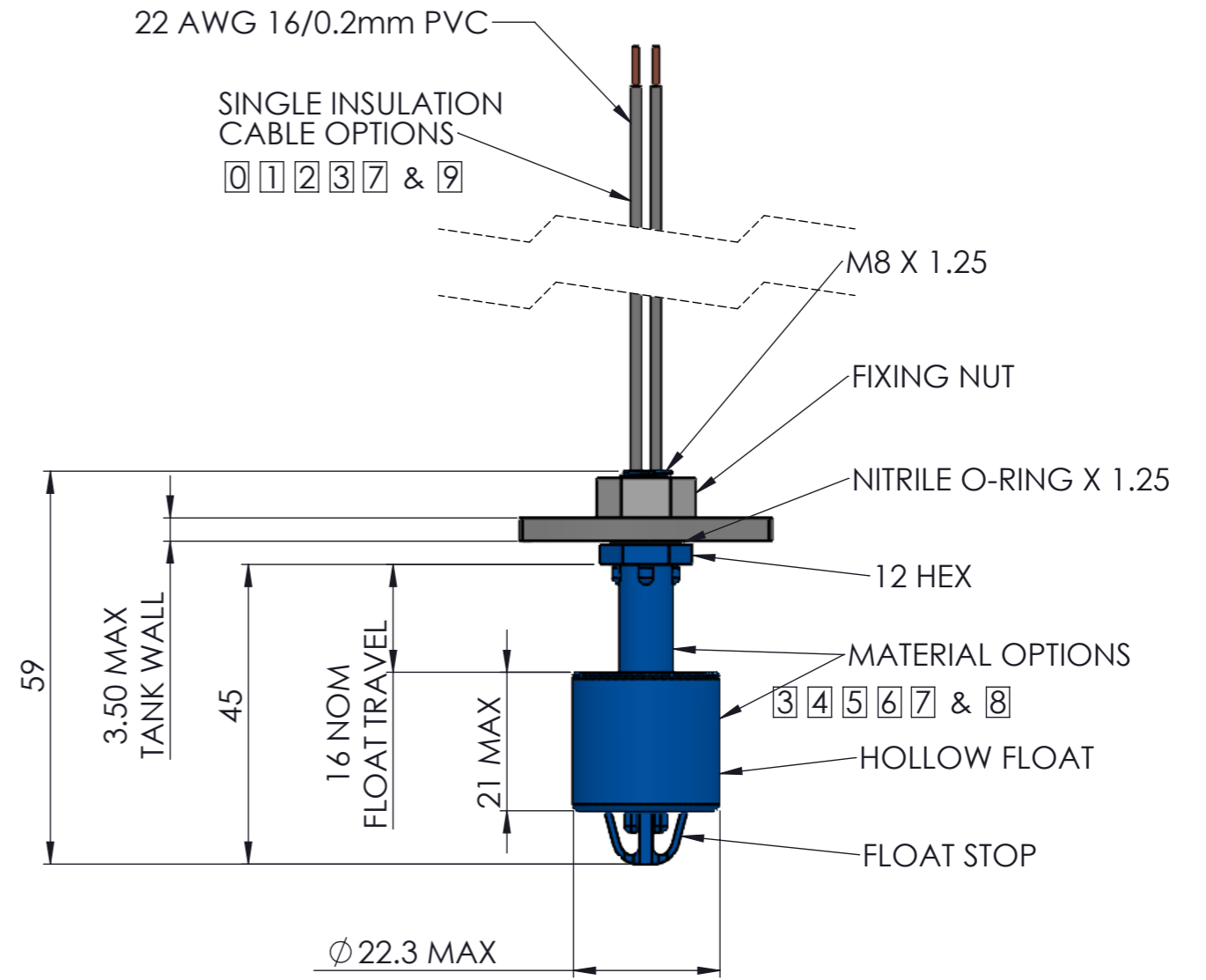

VCS-06

NOTES:

- 1. REED SWITCH IS EITHER NORMALLY OPEN OR CLOSED DEPENDING ON FLOAT ORIENTATION

DIMENSIONS: mm	TOLERANCES UNLESS OTHERWISE SPECIFIED:
	0 PLC -
	1 PLC +0.5
	2 PLC +0.13
	3 PLC +0.013
	4 PLC +0.0001
ANGLES ±	
SURFACE TEXTURE	

DWN L Hernandez	MATERIAL	WEIGHT kg
CHK R Cooper		
APVD J Pendleton		
NAME VCS M8 TOP LEVEL CATALOG DWG		
SCALE 1:1	SIZE A3	DRAWING NO 20017616-00
SHEET 2 OF 2		REV A1

THIS INFORMATION IS CONFIDENTIAL AND PROPRIETARY TO TYCO ELECTRONICS CORPORATION AND ITS WORLDWIDE SUBSIDIARIES AND AFFILIATES (TE). IT MAY NOT BE DISCLOSED TO ANYONE, OTHER THAN TE PERSONNEL, WITHOUT AUTHORIZATION FROM TE (www.TE.com).

D

C

B

A