

LOC J	DIST —	REVISIONS ?o			
P	LTR	DESCRIPTION	DATE	DWN	APVD
	A	RELEASED	04FEB2008	S.I	S.M

FOR P/N 2013523-1
SEE DWG 1871843 SHEET 3

THIS DRAWING IS UNPUBLISHED.

ALL RIGHTS RESERVED.

BY TYCO ELECTRONICS CORPORATION.

© COPYRIGHT

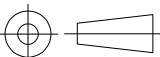
DIMENSIONS: XM? ? mm	DWN	S.INOMATA	04FEB2008	MATERIAL	P? —	FINISH	□ —
	CHK	S.MANABE	04FEB2008	 Tyco Electronics AMP K.K. Kawasaki, Japan			
TOLERANCES UNLESS OTHERWISE SPECIFIED: 、l↑	APVD	S.MANABE	04FEB2008				
0 PLC ± -	PRODUCT SPEC	γA縁<	—	NAME	?o GRACE INERTIA CONNECTOR 2.5		
1 PLC ± -	APPLICATION SPEC	□∅進<縁<	—	HDR ASSY SPECIAL(HSG 3P.TIN VERSION)			RESTRICTED TO —
2 PLC ± -	WEIGHT	—	—	SIZE	CAGE CODE	DRAWING NO	
3 PLC ± -		A4 00779			C-2013523		
4 PLC ± -		CUSTOMER DRAWING			SCALE	SHEET	1 OF 1
ANGLES ± -				?	REV	A	