

THIS DRAWING IS UNPUBLISHED. RELEASED FOR PUBLICATION 20  
 © COPYRIGHT 2011 BY Tyco Electronics Japan G.K. ALL RIGHTS RESERVED.

REVISIONS  
変更

P	LTR	DESCRIPTION	DATE	DWN	APVD
	A	RELEASED	15DEC15	K.S	T.K

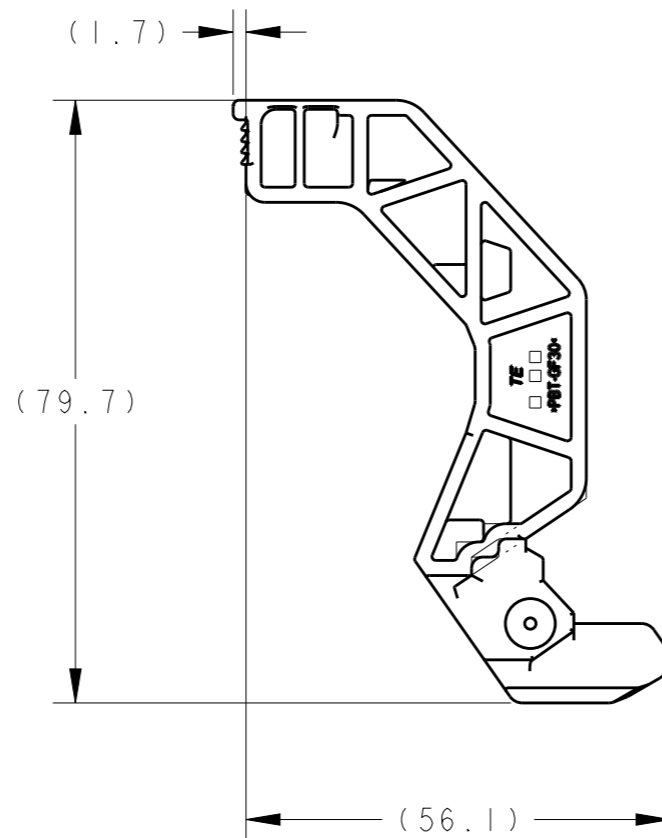
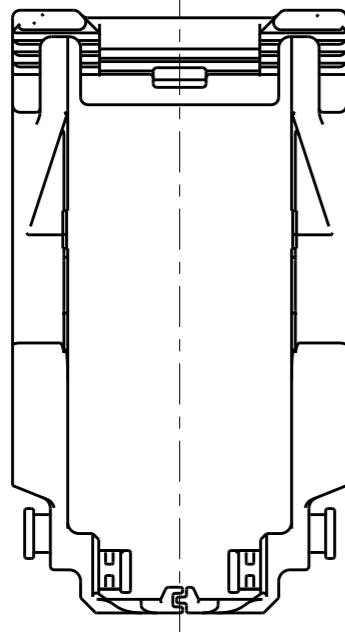

- 1. MATING CONNECTOR  
 TE PART NUMBER: SEE TABLE-1
- 2. HANDLING OF THIS PART SHOULD FOLLOW  
 INSTRUCTION SHEET NO.408-78102
- 3. LEVER IS ASSEMBLED BY CUSTOMER

- 1. 嵌合相手TE品番: TABLE-1参照
- 2. 本部品取扱は取扱説明書NO.408-78102を参照のこと
- 3. レバーは顧客にて組み立てられる

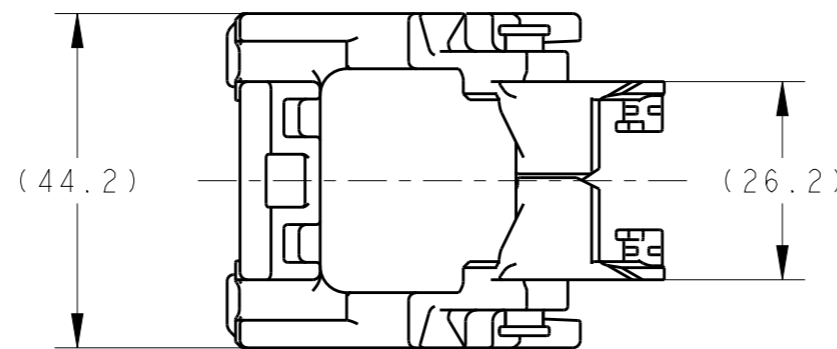
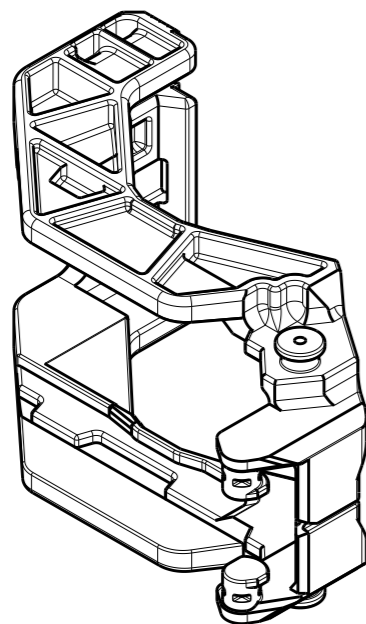

TABLE-1

POS 極数	PLUG ASSEMBLY PART NO. プラグ型番
114	2040105

TABLE-2

GRAY	2040113-1
COLOR	PART NUMBER

THIS DRAWING IS A CONTROLLED DOCUMENT.

DIMENSIONS: 単位: 概 mm		TOLERANCES UNLESS OTHERWISE SPECIFIED:	
		一般公差	±0.3
		0-PLC	±
		1-PLC	±0.5
		2-PLC	±0.13
		3-PLC	±0.013
MATERIAL 材料		FINISH 仕上	
PBT		SEE TABLE-2	

DWN	K. SHIGA	15DEC15
CHK	E. SASAKI	15DEC15
APVD	T. KOHNO	15DEC15
PRODUCT SPEC	108-140084	
APPLICATION SPEC	114-5400, -5470	
WEIGHT	20.92 g	
CUSTOMER DRAWING		



TE Connectivity

NAME 名称				LEVER 114POS, 0.50/1.0/2.8 SEALED TYPE 186POS レバー 114極, 0.50/1.0/2.8 防水タイプ 186極	
SIZE	CAGE CODE	DRAWING NO 番号	RESTRICTED TO		
A3	00779	C=2040113	-		
SCALE 尺度	SHEET	OF	REV	A	