

THIS DRAWING IS UNPUBLISHED. RELEASED FOR PUBLICATION 20
 © COPYRIGHT 20 BY - ALL RIGHTS RESERVED.

1. ASSEMBLY SHOWN FOR REFERENCE ONLY. SHIPPED LOOSE PIECE AS SHOWN ON PAGE 2.
2. ALL ASSEMBLY DIMENSIONS ARE FOR REFERENCE ONLY.
3. THIS PRODUCT HAS NOT COMPLETED VALIDATION TESTING.
4. COMPLETE THE CONNECTOR ASSEMBLY BY ADDING EACH OF THE FOLLOWING:
 - A. TE MINI EXPANDED BEAM INSERT ASSEMBLY;
 - B. MINI EXPANDED BEAM FERRULE KIT, ONE PER FIBER.
 - C. TE PRO BEAM MINI SEALED BULKHEAD CABLE ADAPTER KIT, P/N 1516228-X, SIZED TO THE MAXIMUM CABLE JACKET DIAMETER.

5. FOR TERMINATION TO MIL-TACTICAL, DISTRIBUTION-STYLE CABLE.
 ⚠ PER MIL-DTL-38999L, FIGURE 11, TYPE E.

REVISIONS				
P	LTR	DESCRIPTION	DATE	APVD
A		ECO-14-010160	15JUL2014	KG DW
A1		ECR-15-011044	19AUG2015	KG DW
A2		ECR-15-015330	25JAN2016	KG DW

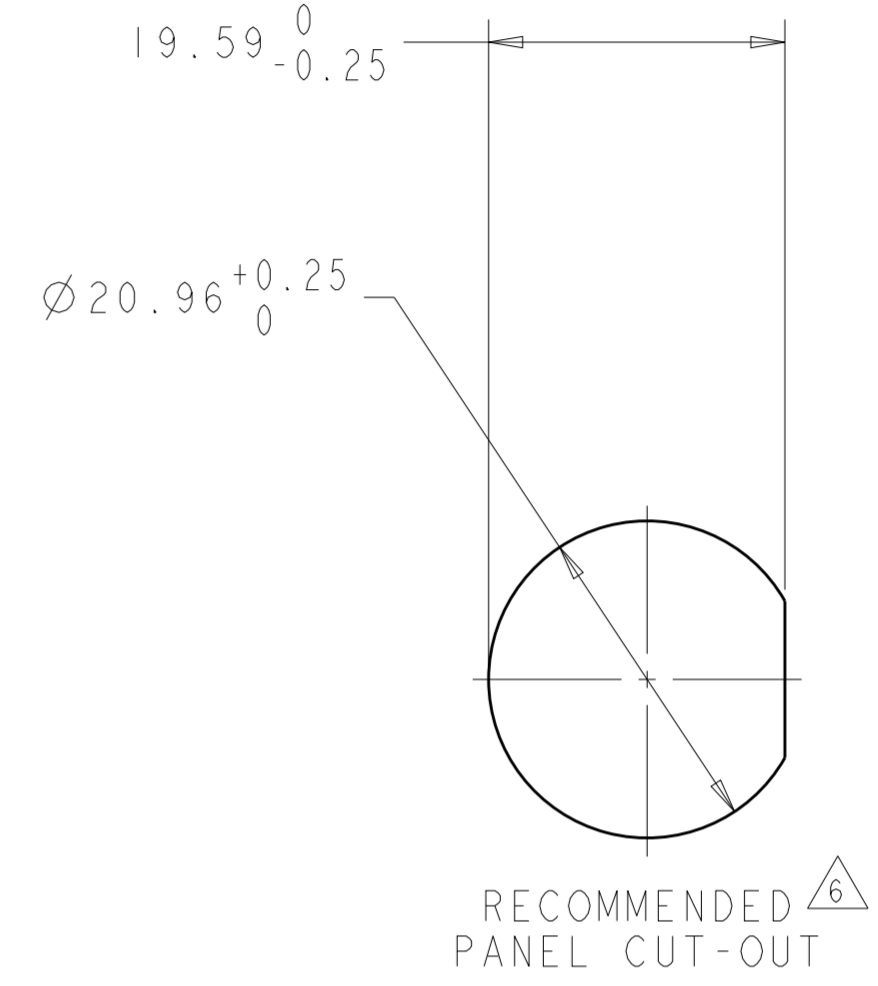
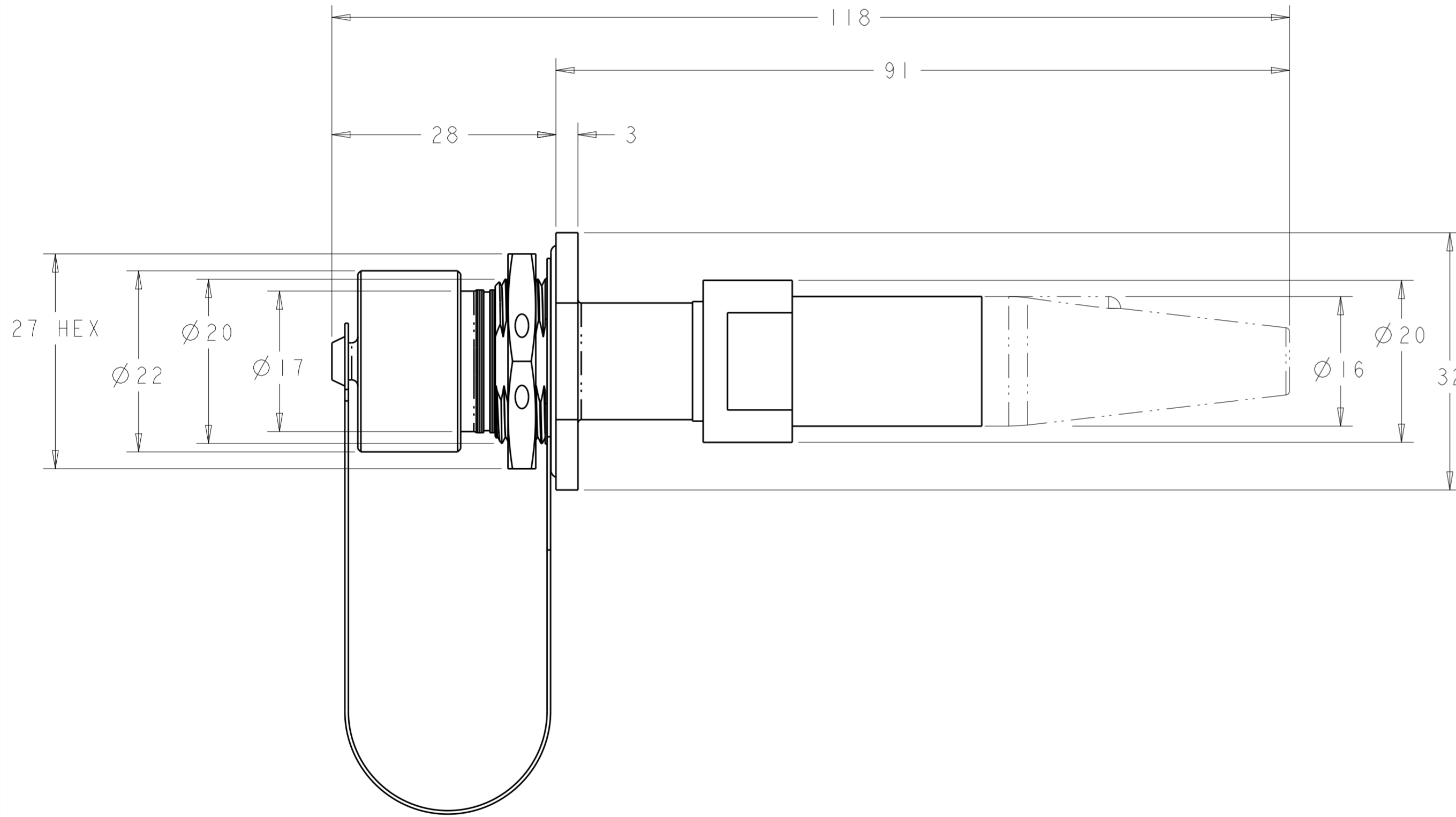

VIEW SHOWN WITH CABLE ADAPTER KIT INSTALLED FOR REFERENCE ONLY

OBSOLETE	A-KEY, BLACK Zn-Ni	A	1-2064163-4
	N-KEY, BLACK Zn-Ni	A	1-2064163-3
OBSOLETE	E-KEY, OLIVE DRAB	A	1-2064163-2
OBSOLETE	D-KEY, OLIVE DRAB	A	1-2064163-1
OBSOLETE	C-KEY, OLIVE DRAB	A	1-2064163-0
OBSOLETE	B-KEY, OLIVE DRAB	A	2064163-9
SUPERSEDED BY: 1-2064163-4	A-KEY, OLIVE DRAB	A	2064163-8
SUPERSEDED BY: 1-2064163-3	N-KEY, OLIVE DRAB	A	2064163-7
OBSOLETE	E-KEY, Ni-PLATE	A	2064163-6
OBSOLETE	D-KEY, Ni-PLATE	A	2064163-5
OBSOLETE	C-KEY, Ni-PLATE	A	2064163-4
OBSOLETE	B-KEY, Ni-PLATE	A	2064163-3
SUPERSEDED BY: 1-2064163-4	A-KEY, Ni-PLATE	A	2064163-2
SUPERSEDED BY: 1-2064163-3	N-KEY, Ni-PLATE	A	2064163-1
	DESCRIPTION	PART REVISION	PART NUMBER

THIS DRAWING IS A CONTROLLED DOCUMENT.		DWN K. GLATFELTER 30APR2008	TE Connectivity	
DIMENSIONS: mm		CHK D. WERTMAN 09MAR2009		
TOLERANCES UNLESS OTHERWISE SPECIFIED:		APVD D. WERTMAN 09MAR2009	NAME D-HOLE BULKHEAD SHELL KIT, 38999 STYLE, SIZE 11, MIL TACTICAL	
0 PLC ±		PRODUCT SPEC	SIZE CAGE CODE DRAWING NO RESTRICTED TO	
1 PLC ±		APPLICATION SPEC	A200779 C-2064163	
2 PLC ±		WEIGHT	SCALE 2:1 SHEET 1 OF 2 REV A2	
3 PLC ±		Customer Drawing		
4 PLC ±				
ANGLES ±				
FINISH				
SEE TABLE				

THIS DRAWING IS UNPUBLISHED. RELEASED FOR PUBLICATION 20
 © COPYRIGHT 20 BY - ALL RIGHTS RESERVED.

REVISIONS				
P	LTR	DESCRIPTION	DATE	APVD
-		SEE SHEET 1	-	-

1. SHIPPED LOOSE PIECE AS SHOWN.

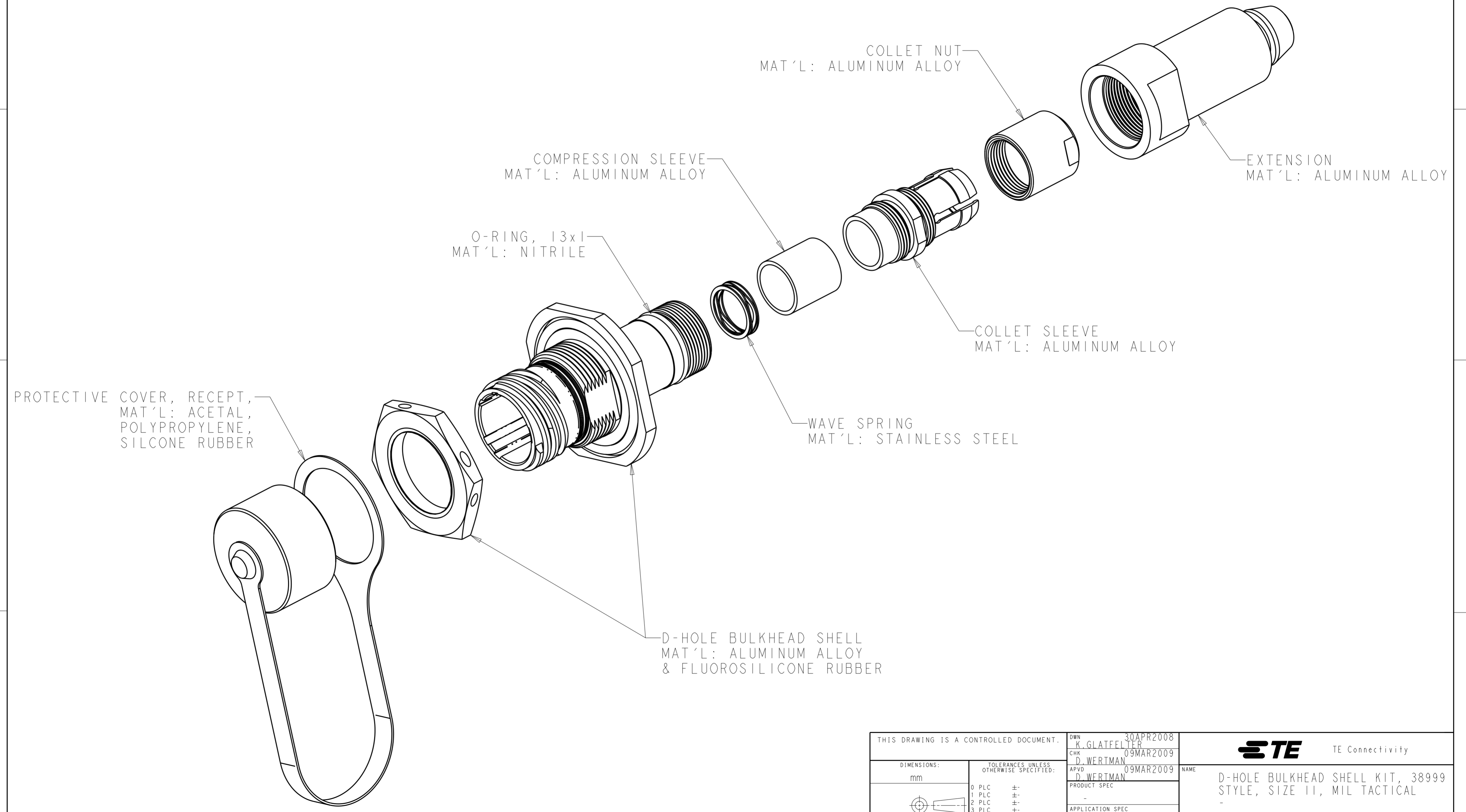

THIS DRAWING IS A CONTROLLED DOCUMENT.		DWN K. GLATFELTER 30APR2008	TE Connectivity	
DIMENSIONS: mm		CHK D. WERTMAN 09MAR2009		
TOLERANCES UNLESS OTHERWISE SPECIFIED:		APVD D. WERTMAN 09MAR2009	NAME D-HOLE BULKHEAD SHELL KIT, 38999 STYLE, SIZE 11, MIL TACTICAL	
0 PLC ± 1 PLC ± 2 PLC ± 3 PLC ± 4 PLC ± ANGLES ± FINISH		PRODUCT SPEC -	SIZE A200779	DRAWING NO C-2064163
MATERIAL -		WEIGHT -	RESTRICTED TO -	SCALE 2:1
SEE TABLE SHEET 1		Customer Drawing	SHEET 2 OF 2	REV A2