

REVISIONS					
P	LTR	DESCRIPTION	DATE	DWN	APVD
A		Go to production	01SEP2022	ED	WH

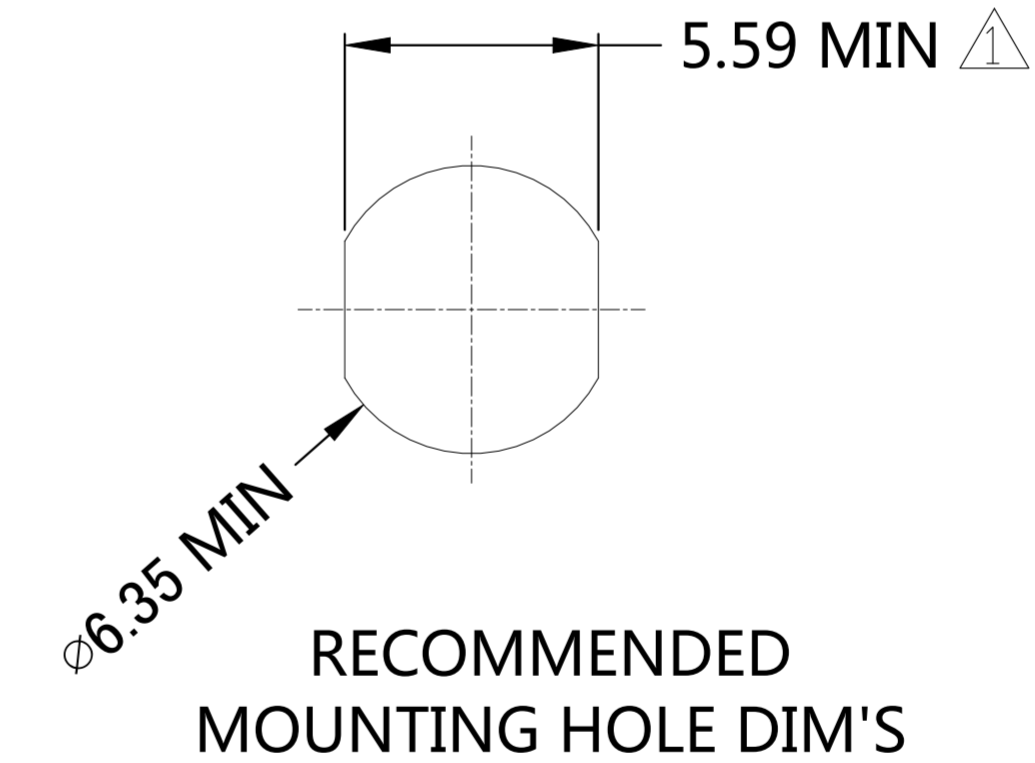
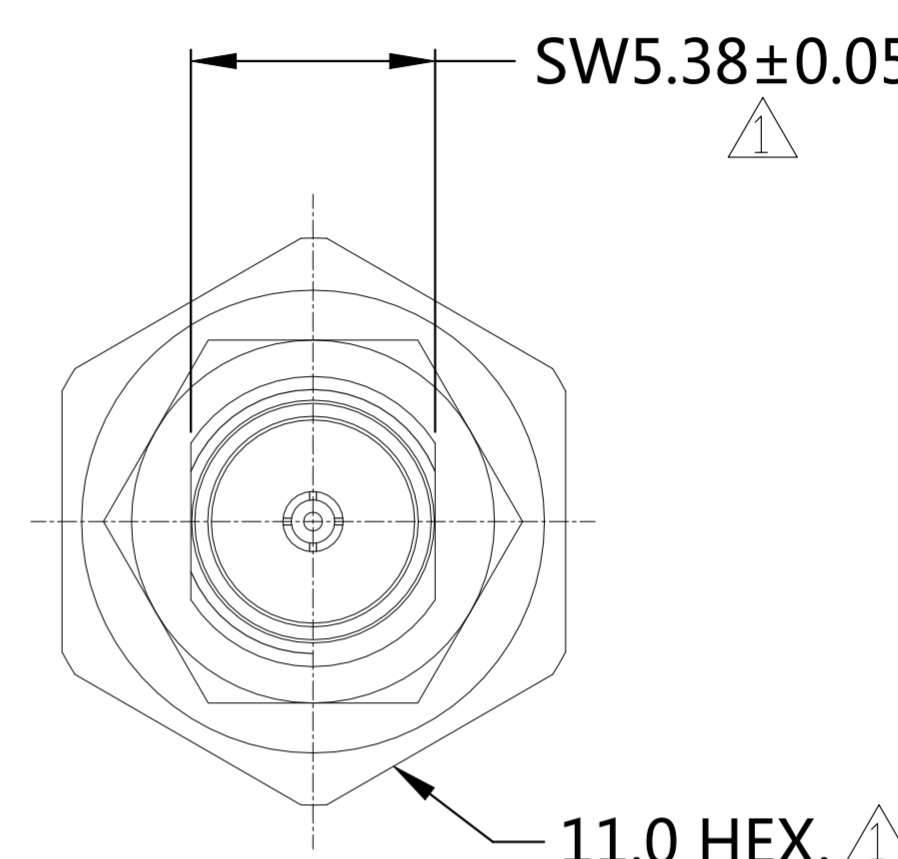
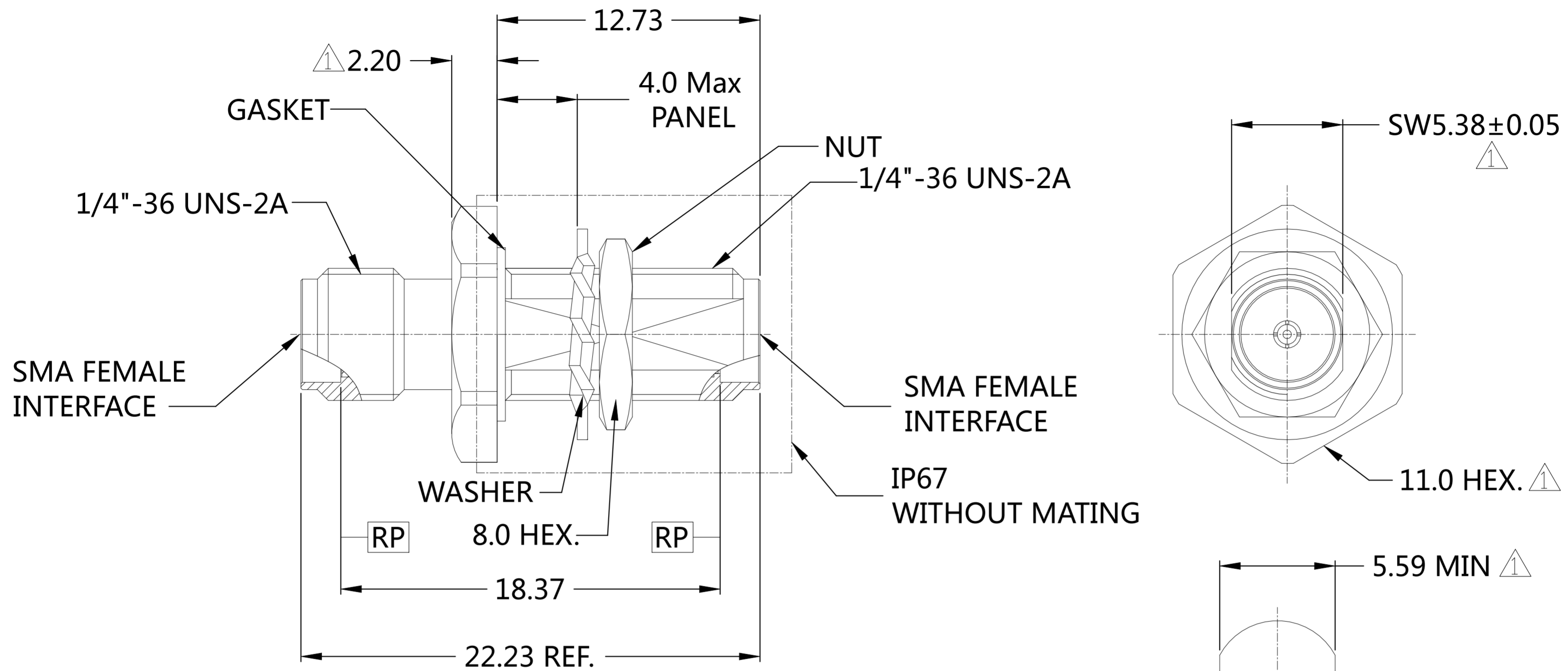

- NOTES:
- 1 PACK IN ACCORDANCE WITH TE SPEC 107-3275;
 - 2 ALL DIMENSIONS ARE NOMINAL FOR REFERENCE ONLY UNLESS OTHERWISE STATED.

ELECTRICAL	MECHANICAL	ENVIRONMENTAL
Impedance (Ohm) _____50	Interface Dimension MIL-STD-348B Fig. _____310-2	TEMPERATURE RANGE _____ -55° - +125°
Frequency Range (GHz) _____DC to 26.5GHz	Recommended Coupling Torque _____7 to 10 In-Lbs	THERMAL SHOCK _____MIL-STD-202, METH.107, COND.B
Voltage Rating (Peak) _____@ Sea Level 335 V RMS	Force to Engage and Disengage (In/lbs) _____2.0 MAX	CORROSION _____MIL-STD-202, METH.101, COND.B
Insulation Resistance (MIN.) _____5000 M ohms	Center Contact Captivation Axial (Lbs) _____>6 LBS Radial (In/Oz) _____N/A	VIBRATION _____MIL-STD-202, METH.204, COND.D
Contact Resistance (Milliohms MAX) Center Contact _____3.0 Outer Contact _____2.0	Cable Retention Axial (Lbs) _____N/A	SHOCK _____MIL-STD-202, METH.213, COND.I
Dielectric Withstand Voltage: _____750 V RMS Max	Mating cycles _____500 cycles	MOISTURE RESISTANCE _____MIL-STD-202, METH.106.
Insertion Loss : _____0.1SQRT(FGHz) dB		ROHS _____COMPLIANT
VSWR: _____1.30 MAX(DC-20GHz)		
RF leakage: _____N/A		
3rd Intermodulation: _____N/A		

QUANTITY PER ASSY	DESCRIPTION	MATERIAL	ITEM
1	RED	SILICONE	GASKET
1	PASSIVATION	STAINLESS STEEL	NUT
1	PASSIVATION	STAINLESS STEEL	WASHER
1	/	PTFE	INSULATOR
1	GOLD 30u"/NICKEL/COPPER	BERYLLIUM COPPER	CENTER CONTACT
1	PASSIVATION	STAINLESS STEEL	BODY

THIS DRAWING IS A CONTROLLED DOCUMENT.

DWN	ED	12JUN2022
CHK	RZ	12JUN2022
APVD	WH	12JUN2022

TE Connectivity

NAME: SMA, ADAPTER F TO F, 26.5GHz, STRAIGHT, BULKHEAD

SIZE	CAGE CODE	DRAWING NO	RESTRICTED TO
A2	00779	C=2081363	-

SCALE: 8:1 SHEET: 1 OF 1 REV: A