

P	LTR	DESCRIPTION	DATE	DWN	APVD
1		INITIAL RELEASE	06MAY2020	SJ	JH
2		UPDATE PATTERN	14MAY2020	SJ	JH
A		RELEASED PRODUCTION	12JUN2020	SJ	JH
AI		REVISED PER ECO-20-012224	18AUG2020	SJ	JH

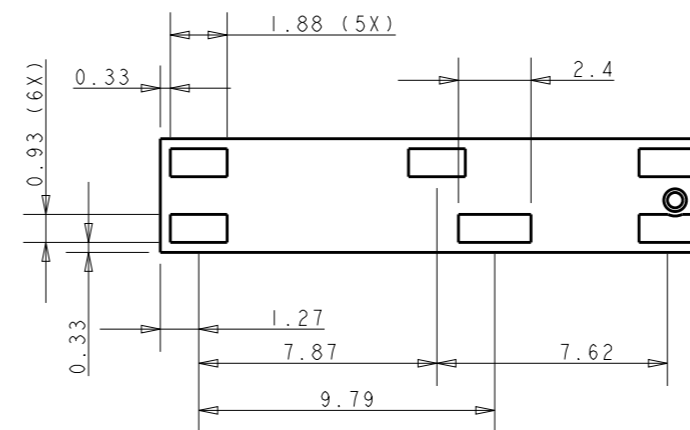
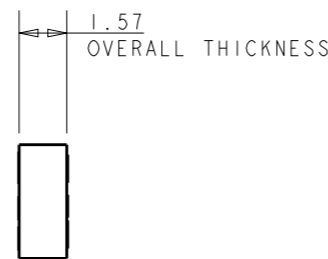
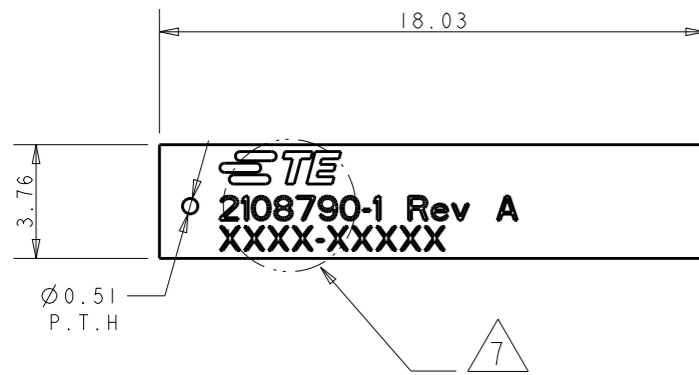

NOTES: UNLESS OTHERWISE SPECIFIED.

- FABRICATE TO MEET IPC - 6013, CLASS 2. INSPECT TO MEET IPC - A - 600, CLASS 2.
- MATERIAL : FR-4 PCB. 1.57 THK
- FINISH:
A: SOLDERMASK BOTH SIDES: ORANGE.
B: ENIG PLATING.
- GENERAL TOLERANCE : ±0.2.
- PACKAGING: SINGULATED PARTS TO BE SECURELY SHRINK WRAPPED, BAGGED OR VACUUM PACKED IN BULK FOR TAPE AND REEL, SEE SHEET 2.
- CONSULT TE CONNECTIVITY DATA SHEET DS2108790.
- SILKSCREEN; WHITE EPOXY INK.
A. TE LOGO, TE P/N
B. WORD REV., FOLLOWED BY THE LATEST REVISION LETTER, AS SHOWN.
C. 4 DIGIT DATE CODE: FIRST 2 DIGITS FOR THE WEEK CODE AND THE 2ND TWO DIGITS FOR THE YEAR CODE.
OTHERS : SPECIFIC TE SOURCE CODE NUMBER DIGITS AS REQUIRED.

BULK PACKAGED	2108790-1
TAPE AND REELED	2108790-2
PACKAGING	PART NUMBER

THIS DRAWING IS A CONTROLLED DOCUMENT.		DWN SJ.NOH	06APR2020	TE Connectivity NAME BLUETOOTH 802.11B ANTENNA	
DIMENSIONS: mm		CHK H.SHIN	06APR2020		
TOLERANCES UNLESS OTHERWISE SPECIFIED:		APVD JH.KIM	06APR2020		
0 PLC ± 1 PLC ± 2 PLC ± 3 PLC ± 4 PLC ± ANGLES ±		PRODUCT SPEC	-		
MATERIAL TBD		FINISH	-	APPLICATION SPEC	-
		WEIGHT	-	SIZE	A3
		CUSTOMER DRAWING		CAGE CODE	00779
				DRAWING NO	C-2108790
				RESTRICTED TO	
				SCALE	4:1
				SHEET	1 OF 3
				REV	AI

P	LTR	DESCRIPTION	DATE	DWN	APVD
-	-	SEE SHEET 1	-	-	-

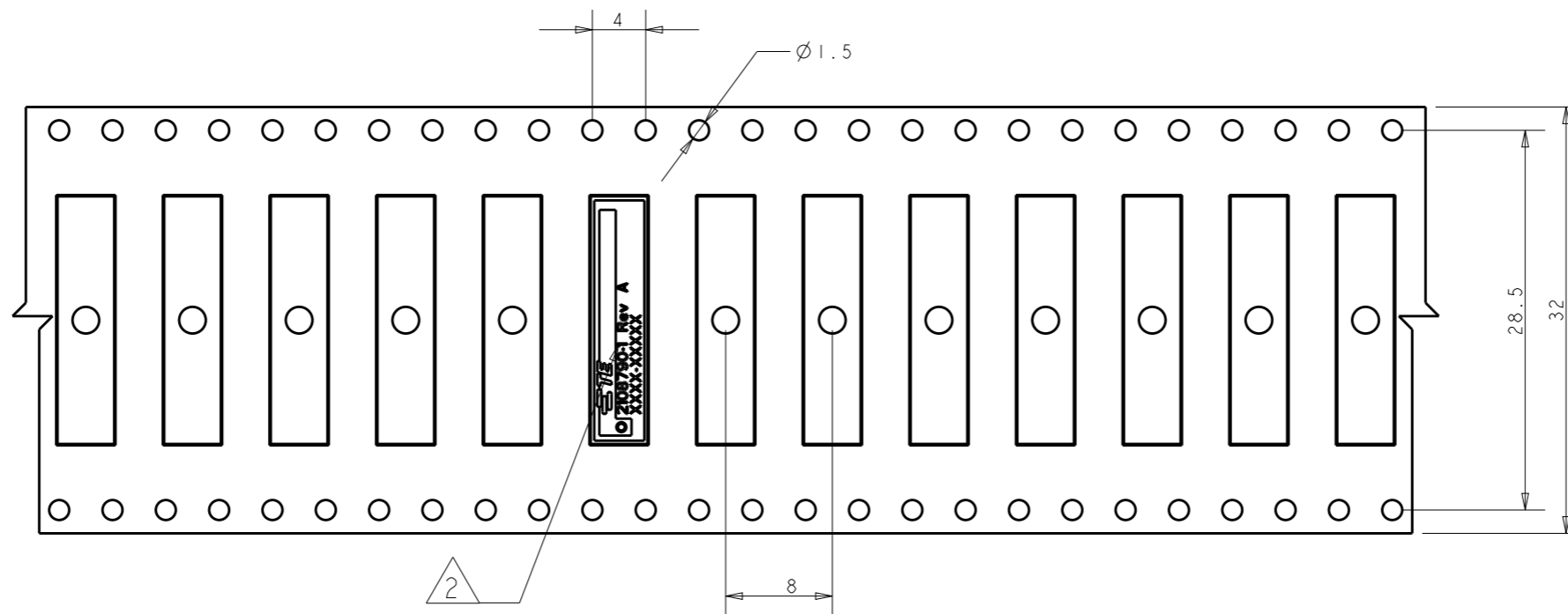

21108790-2 AS SHOWN

USER DIRECTION OF UNREELING

NOTES:

1. UNLESS OTHERWISE SPECIFIED.
2. ORIENT PARTS AS SHOWN

THIS DRAWING IS A CONTROLLED DOCUMENT.		DWN	SJ.NOH	06APR2020													
DIMENSIONS: mm		CHK	H.SHIN	06APR2020													
TOLERANCES UNLESS OTHERWISE SPECIFIED:		APVD	JH.KIM	06APR2020													
<table border="0"> <tr> <td>0 PLC</td> <td>±</td> </tr> <tr> <td>1 PLC</td> <td>±</td> </tr> <tr> <td>2 PLC</td> <td>±</td> </tr> <tr> <td>3 PLC</td> <td>±</td> </tr> <tr> <td>4 PLC</td> <td>±</td> </tr> <tr> <td>ANGLES</td> <td>±</td> </tr> </table>		0 PLC	±	1 PLC		±	2 PLC	±	3 PLC	±	4 PLC	±	ANGLES	±	PRODUCT SPEC	NAME	
0 PLC	±																
1 PLC	±																
2 PLC	±																
3 PLC	±																
4 PLC	±																
ANGLES	±																
MATERIAL	TBD	FINISH	-	APPLICATION SPEC	-												
-		WEIGHT	-	SIZE	A3												
-		CUSTOMER DRAWING	SCALE	4:1	SHEET 2 OF 3												
-		RESTRICTED TO	REV	A1													

REVISIONS					
P	LTR	DESCRIPTION	DATE	DWN	APVD
	-	SEE SHEET 1	-	-	-

2108790-1 PACKAGING

20BAG/BOX
(10000PCS/BOX)

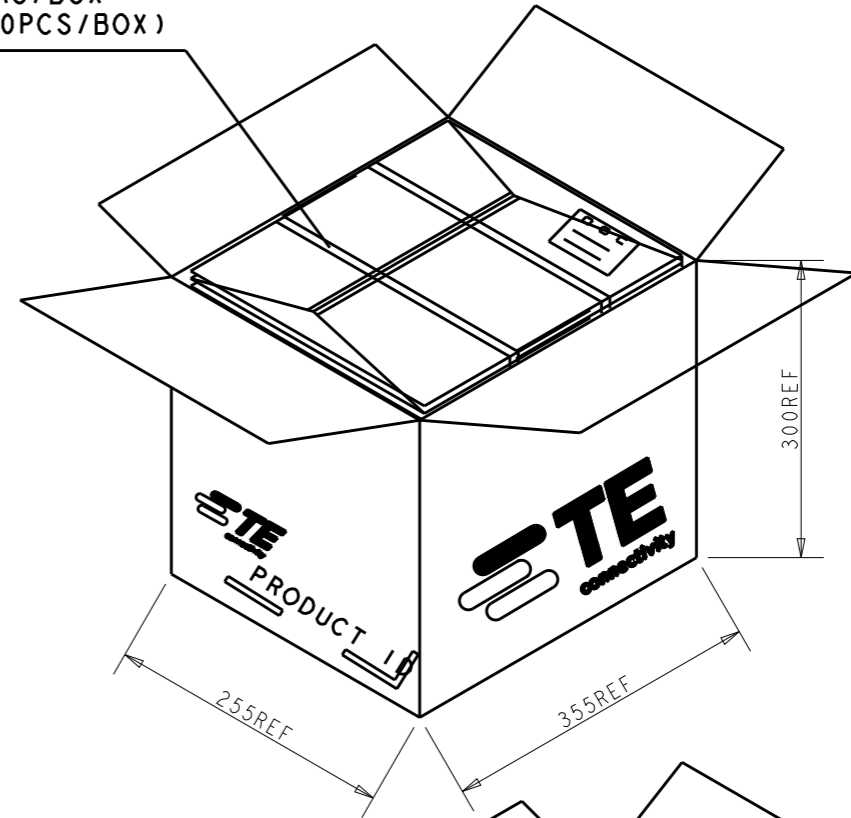
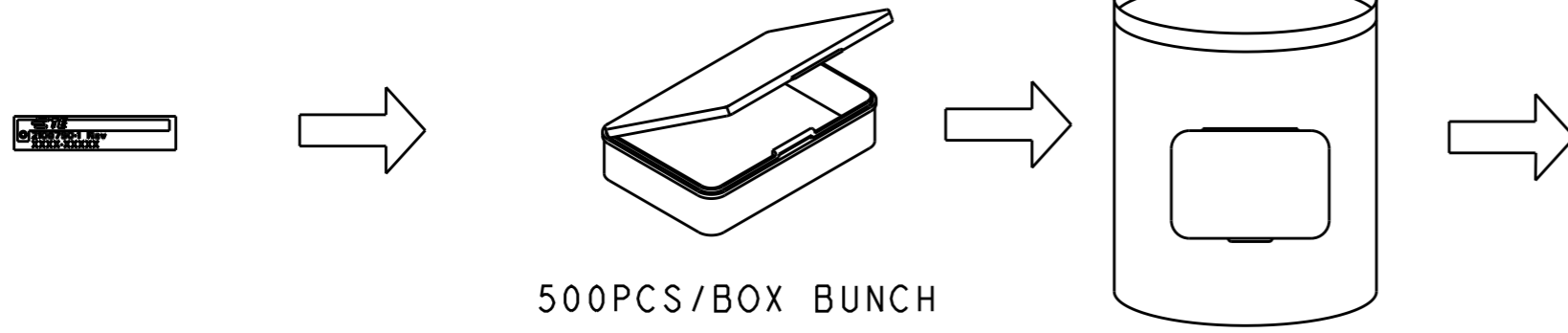

2108790-2 PACKAGING

3PCS/REEL
(10500PCS/BOX)

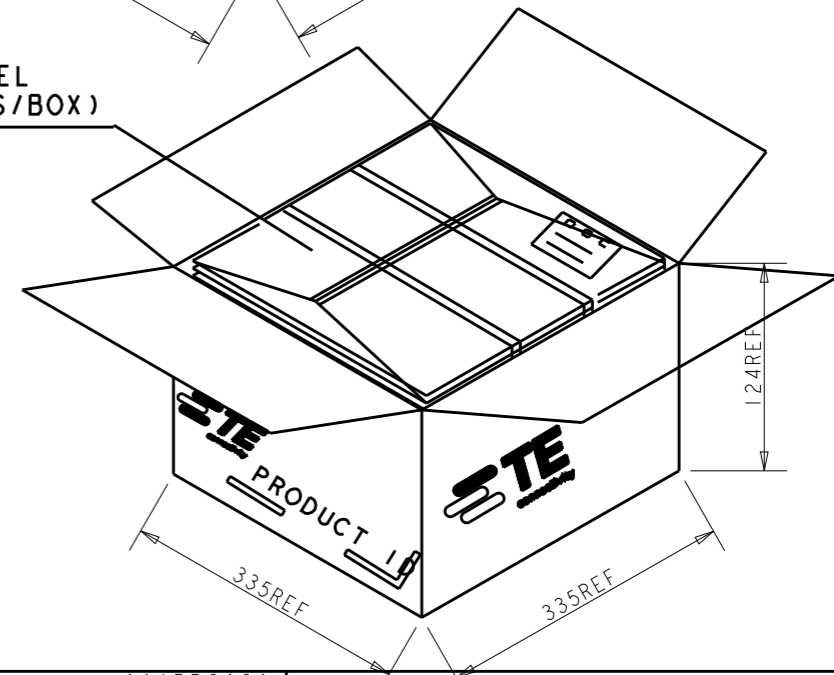
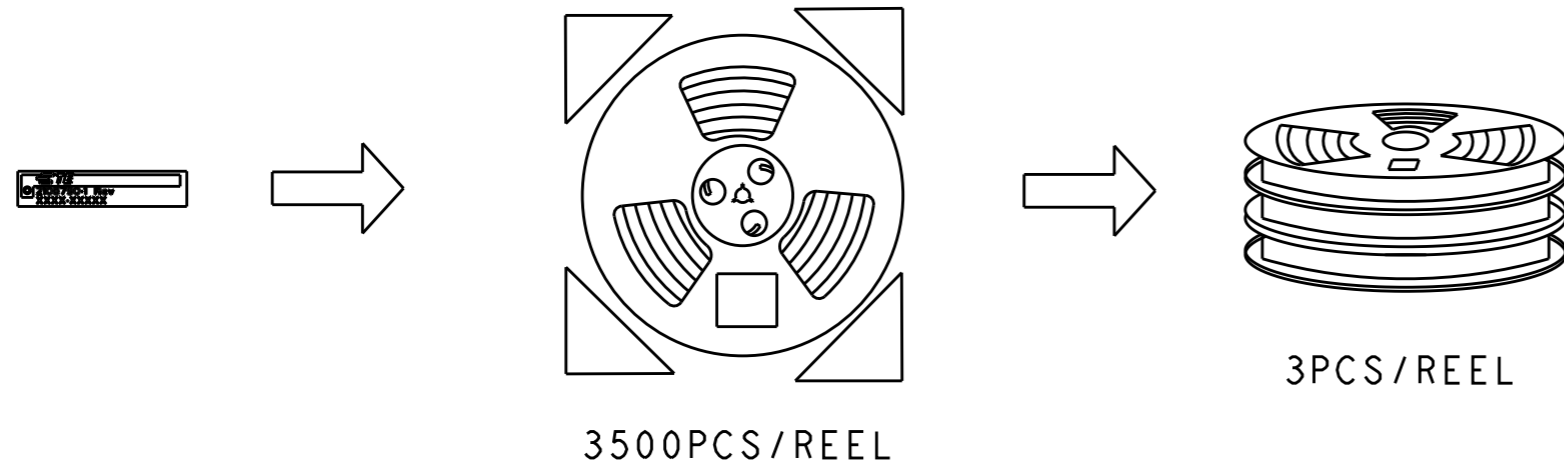

THIS DRAWING IS A CONTROLLED DOCUMENT.		DWN S.J. NOH 06APR2020	 TE Connectivity	
DIMENSIONS: mm		CHK H. SHIN 06APR2020		
TOLERANCES UNLESS OTHERWISE SPECIFIED:		APVD JH. KIM 06APR2020	NAME BLUETOOTH 802. 11B ANTENNA	
0 PLC ±-		PRODUCT SPEC	-	
1 PLC ±		APPLICATION SPEC	-	
2 PLC ±		WEIGHT	-	
3 PLC ±		CUSTOMER DRAWING	-	
4 PLC ±		SCALE	4:1	
ANGLES ±		SIZE	A3	
FINISH		CAGE CODE	300779	
MATERIAL TBD		DRAWING NO	G-2108790	
-		RESTRICTED TO	-	
-		SHEET	3 OF 3	
-		REV	A1	