

REVISIONS					
P	LTR	DESCRIPTION	DATE	DWN	APVD
A3		Updated drawing	10JUN2020	SJ	JH
A4		ADD NEWLY PARTS	13AUG2020	SJ	JH
B		REVISED PER ECO-20-015489	04NOV2020	SJ	JH
B1		REVISED PER ECN-25-312045	19MAR2025	DW	VK

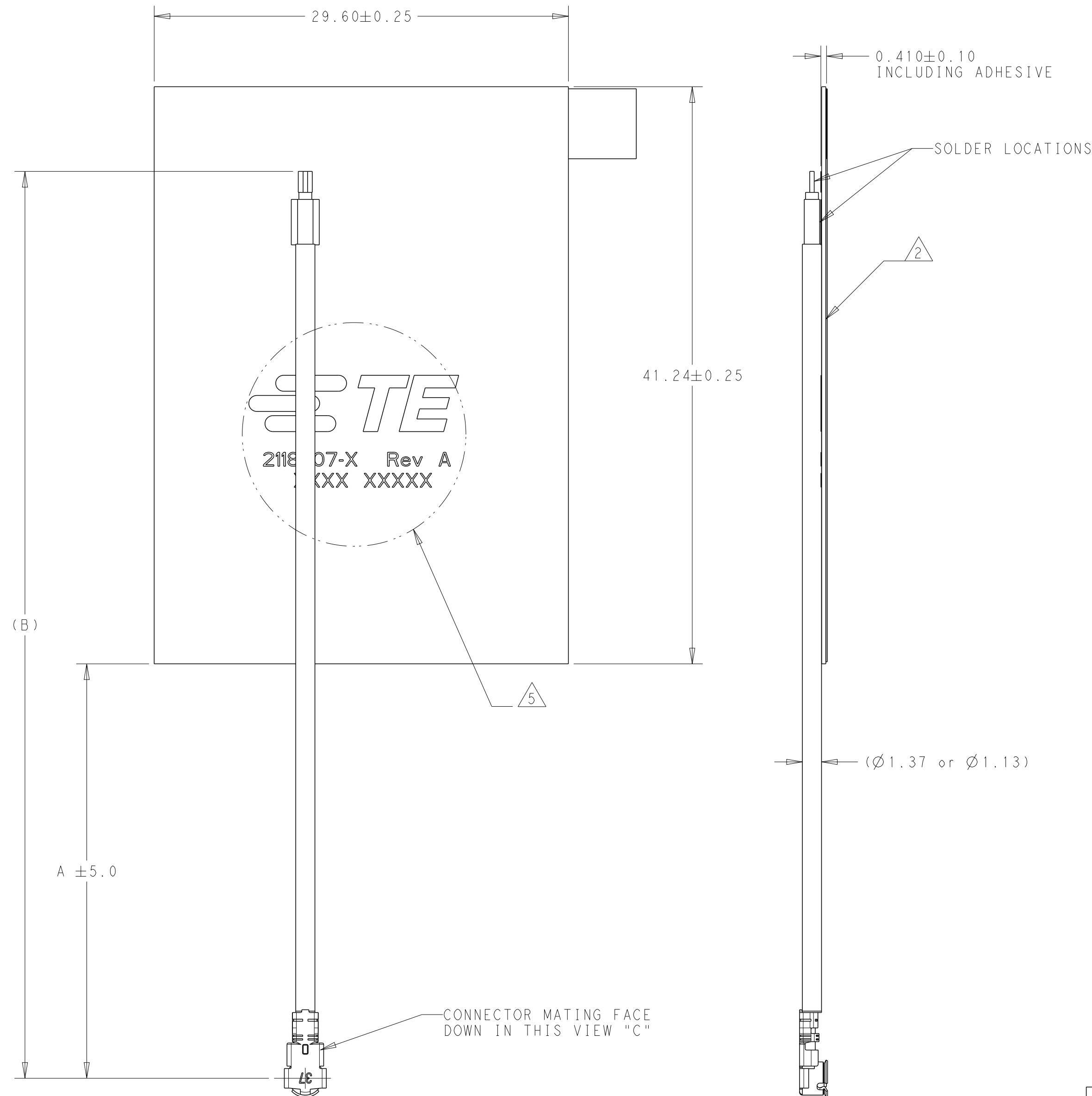

NOTES: UNLESS OTHERWISE SPECIFIED.

- FABRICATE TO MEET IPC - 6012, CLASS 2. INSPECT TO MEET IPC - A - 600, CLASS 2.
- MATERIAL :
A. FR-4 PCB + DOUBLE SIDED ADHESIVE 0.41 THK.
B. ADHESIVE WITH LINER ON THE BACK SIDE. REMOVE LINER TO APPLY
- PACKAGING: SINGULATED PARTS TO BE SECURELY BAG WRAPPED, BAGGED OR VACUUM PACKED IN BULK.
- CONSULT TE CONNECTIVITY DATA SHEET DS2118907.
- SILKSCREEN; WHITE EPOXY INK
A. TE LOGO, TE P/N
B. WORD REV., FOLLOWED BY THE LATEST REVISION LETTER, AS SHOWN.
C. 4 DIGIT DATE CODE : FIRST 2 DIGITS FOR THE WEEK CODE AND THE 2ND TWO DIGITS FOR THE YEAR CODE.
OTHERS : SPECIFIC TE SOURCE CODE NUMBER DIGITS AS REQUIRED.

MHF4L (OD:1.13)	(335.2)	300.0	1-2118907-4
	(285.2)	250.0	1-2118907-3
	(235.2)	200.0	2118907-9
	(185.2)	150.0	2118907-8
	(135.2)	100.0	2118907-7
	(85.2)	50.0	2118907-6
MHF (OD:1.37)	(335.2)	300.0	1-2118907-2
	(285.2)	250.0	1-2118907-1
	(235.2)	200.0	2118907-5
	(185.2)	150.0	2118907-4
	(150.0)	114.8	2118907-1
	(135.2)	100.0	2118907-3
(85.2)	50.0	2118907-2	
"C" CONNECTOR TYPE	"(B)"	"A"	PART NUMBER

THIS DRAWING IS A CONTROLLED DOCUMENT.		DWN S.J. NOH 29APR2020		
DIMENSIONS: mm		CHK H. SHIN 29APR2020		
TOLERANCES UNLESS OTHERWISE SPECIFIED:		APVD JH. KIM 29APR2020	NAME PCB Ant, MHF/MHF4L, Wi-Fi 6E Triple	
		PRODUCT SPEC	-	
MATERIAL		APPLICATION SPEC	-	
-		WEIGHT	-	
-		CUSTOMER DRAWING	SCALE A2	DRAWING NO. C-2118907
-		FINISH	-	
-		RESTRICTED TO	-	
-		SCALE	4:1	SHEET 1 OF 1
-		REV	B1	