

REVISIONS					
P	LTR	DESCRIPTION	DATE	DMN	APVD
M1	REV PER ECO	18-010893	9-17-18	CT	DM

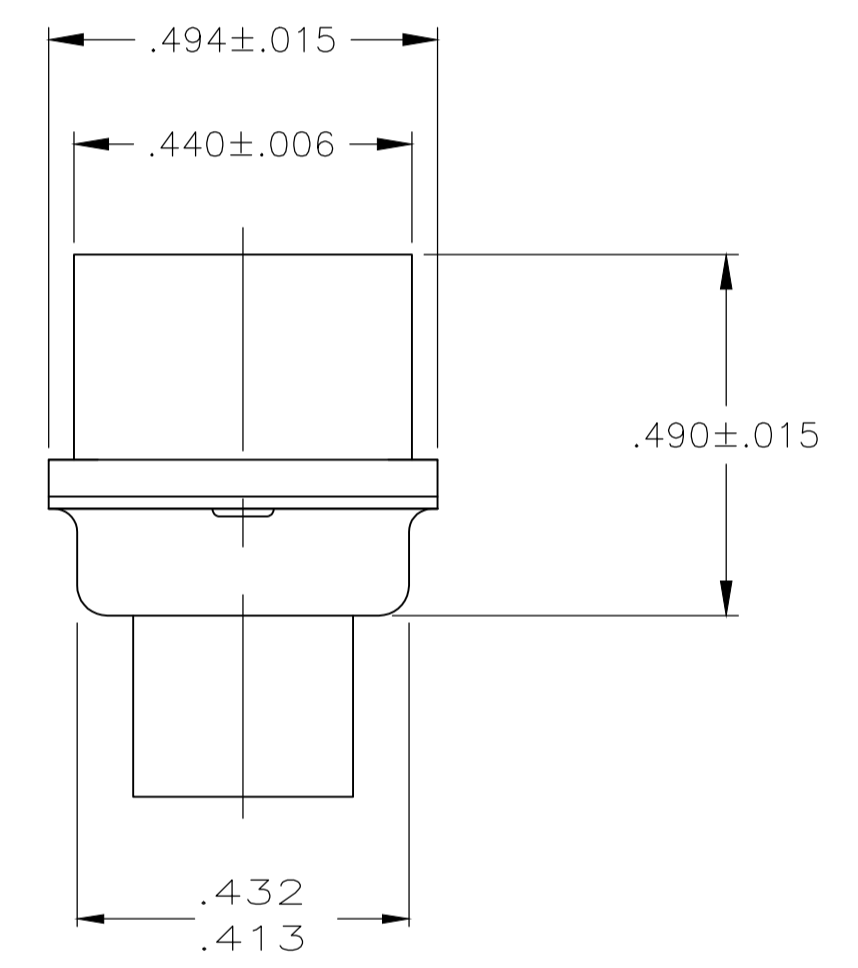
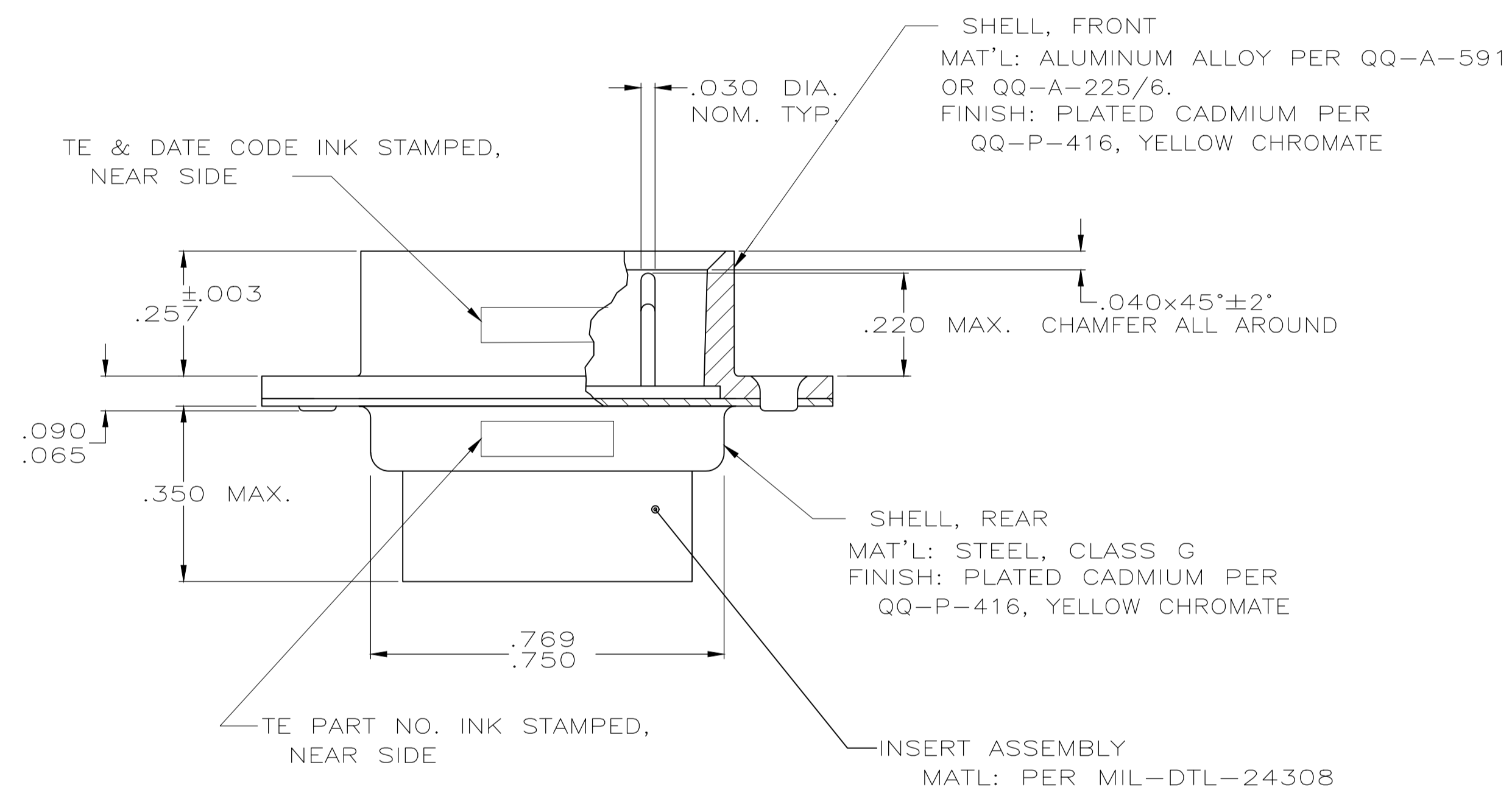
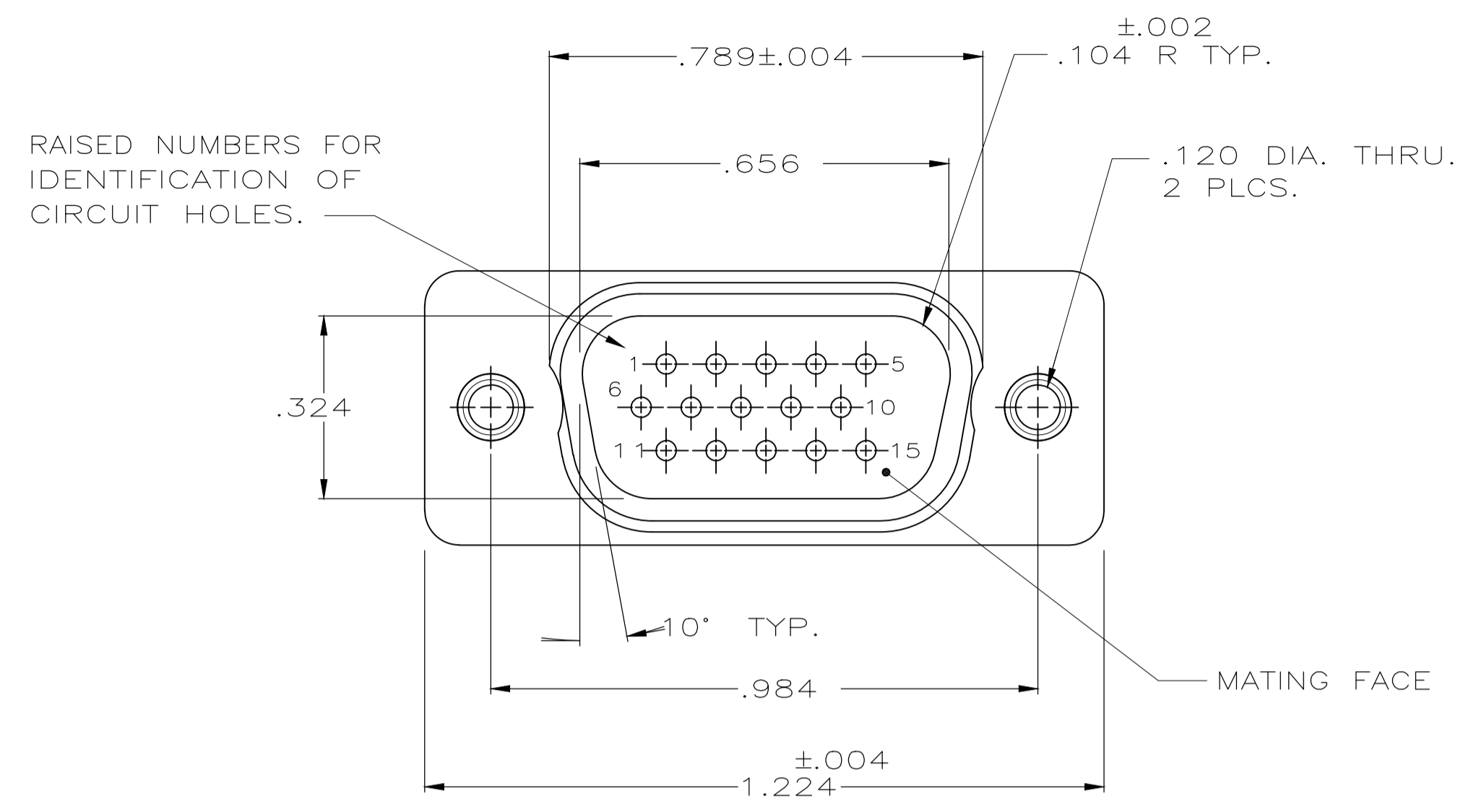

- THIS PLUG WILL MATE WITH ANY 15 POSN., SIZE 1 RECEPTACLE IN AMPLIMITE SERIES.
- MAXIMUM WIRE INSULATION TO BE USED WITH THIS PLUG IS  $.054$  DIA.
- SST RETENTION CLIPS ARE INCLUDED IN INSERTS.
- THIS PLUG IS DESIGNED TO CONFORM TO THE LATEST ISSUE OF MIL-C-24308.
- CONNECTOR SUPPLIED WITHOUT CONTACTS; SHOWN FOR ILLUSTRATION ONLY.
- THIS PLUG WILL ACCEPT SIZE 22 DM PIN CONTACT M39029/58-22-22D OR ANY AMP SIZE 22 DF PIN CONTACT.

213153-1  
PART NUMBER

THIS DRAWING IS A CONTROLLED DOCUMENT.		DIN D.D.ERDMAN 10-17-85	TE Connectivity	
DIMENSIONS: INCHES		CHK F.C.BALLEW III 10-25-85	NAME PLUG ASSY., AMPLIMITE, 15 POSN., SIZE 1, SERIES 90, BLINDMATE	
TOLERANCES UNLESS OTHERWISE SPECIFIED:		APVD	PRODUCT SPEC	
0. PLC ± -		APPLICATION SPEC		
1. PLC ± -		SIZE		
2. PLC ± -		CAGE CODE		
3. PLC ± .005		DRAWING NO		
4. PLC ± -		RESTRICTED TO		
ANGLES ± -		WEIGHT 0.000000		
FINISH SEE CALLOUT		A1 00779 C=213153		
MATERIAL SEE CALLOUT		CUSTOMER DRAWING		
		SCALE 1:1 SHEET 1 OF 1 REV M1		