

THIS DRAWING IS UNPUBLISHED. RELEASED FOR PUBLICATION  
 © COPYRIGHT BY TYCO ELECTRONICS CORPORATION. ALL INTERNATIONAL RIGHTS RESERVED.

LOC		DIST		REVISIONS			
P	LTR	DESCRIPTION	DATE	DWN	APVD		
	B	RELEASED PER ECO-10-026386	29DEC10	PY	DW		

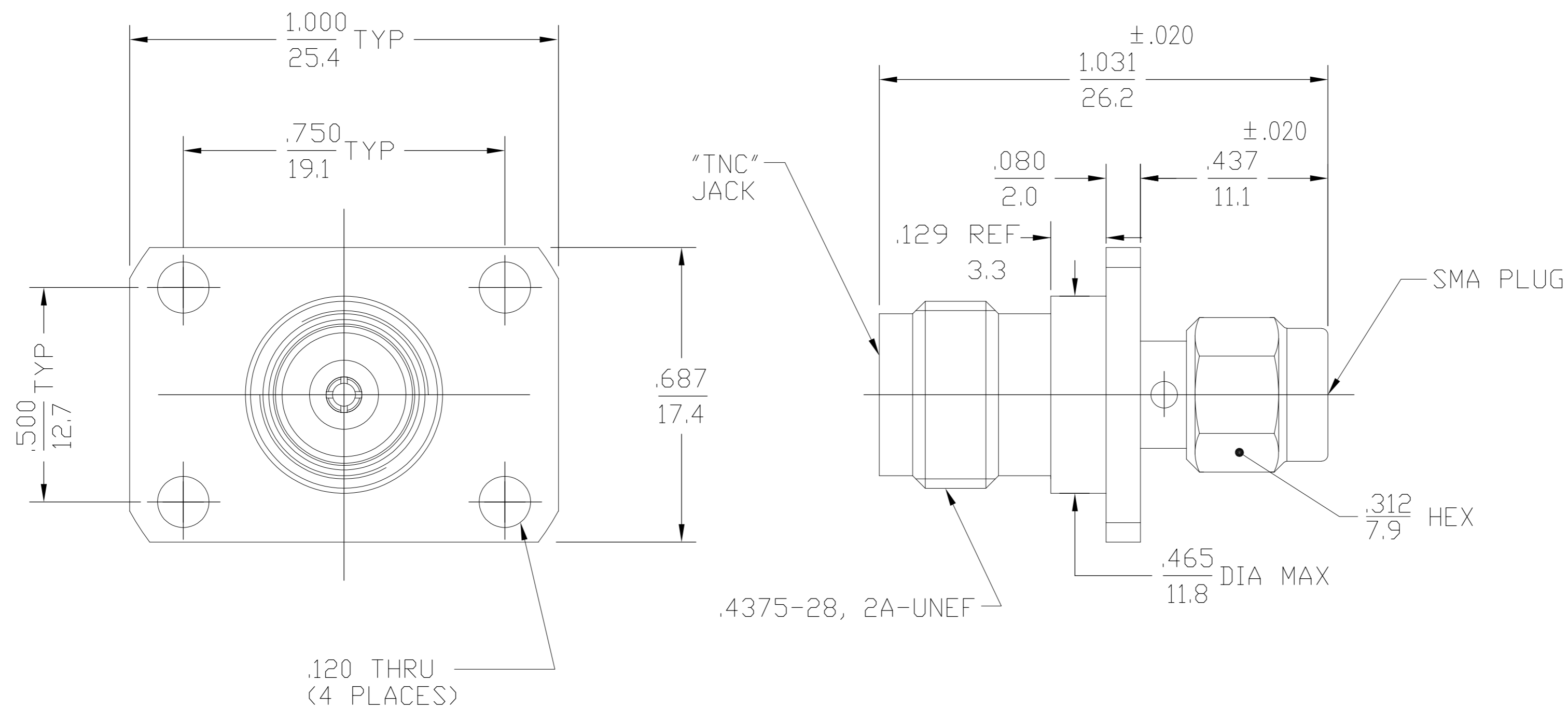

1. CAPTURED CENTER CONTACT.

HOUSING COUPLING NUT	STAINLESS STEEL PER ASTM-A484 AND ASTM-A582, TYPE 303	PASSIVATE PER QQ-P-35
DIELECTRIC	TFE FLUOROCARBON PER ASTM-D-1457	N/A
CENTER CONTACT	BERYLLIUM COPPER PER ASTM-B-196 OR ASTM-B-197, ALLOY C17300, CONDITION H	GOLD PLATE PER MIL-G-45204
RETAINING RING	BERYLLIUM COPPER PER ASTM-B-194, ALLOY C17200, CONDITION H	GOLD PLATE PER MIL-G-45204
GASKET	SILICONE RUBBER PER ZZ-R-765	N/A

COMPONENT	MATERIAL	FINISH
-----------	----------	--------

2157264-1  
PART NO.

THIS DRAWING IS A CONTROLLED DOCUMENT.		DWN P. YEAGER 29DEC2010	Tyco Electronics Corporation Harrisburg, PA 17105-3608	
DIMENSIONS: INCHES		CHK D. WILSON 29DEC10	NAME BETWEEN SERIES ADAPTER TNC JACK TO SMA PLUG	
TOLERANCES UNLESS OTHERWISE SPECIFIED:		APVD D. WILSON 29DEC10	PRODUCT SPEC	
0 PLC ± -		APPLICATION SPEC		
1 PLC ± -		WEIGHT -		
2 PLC ± -		SCALE A2 00779 C=2157264		
3 PLC ± -		SHEET 1 of 1		
4 PLC ± -		REV B		
ANGLES ± -		CUSTOMER DRAWING		
FINISH -		RESTRICTED TO -		