

P	LTR	DESCRIPTION	DATE	DWN	APVD
	BA	NEW DRAWING RELEASE	18AUG2023	DM	AP
	BA1	REMOVE MARKING FROM IMAGE	22AUG2023	DM	AP

FOR FURTHER INFORMATION SEE DATA SHEET FOR
MINIATURE SMD POWER INDUCTOR TYPE 3627 SERIES

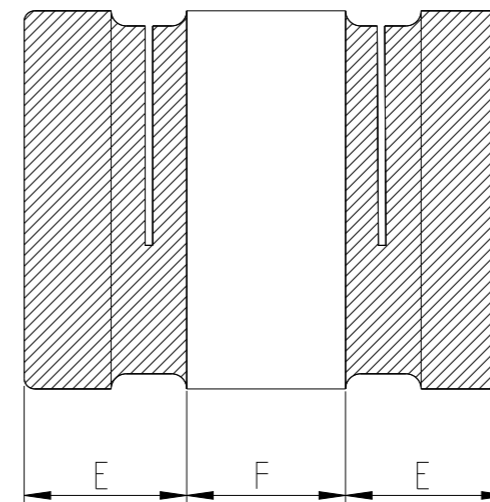
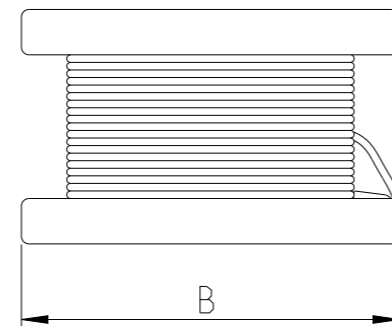
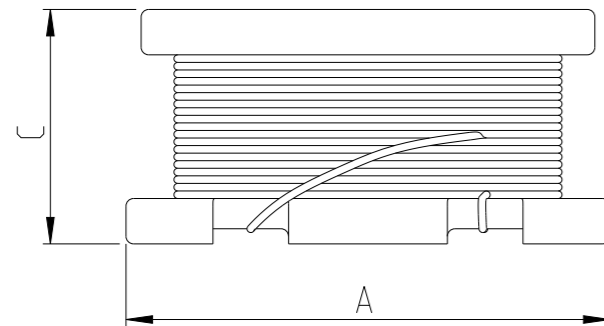

A	B	C	E	F
3.2±0.3	2.5±0.2	1.55±0.3	1.05±0.3	1.05±0.3

RoHS Compliant

RECOMMENDED LAND PATTERN

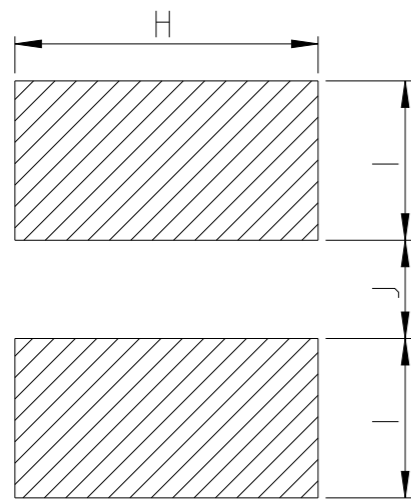

H	I	J
2.0	1.5	1.0

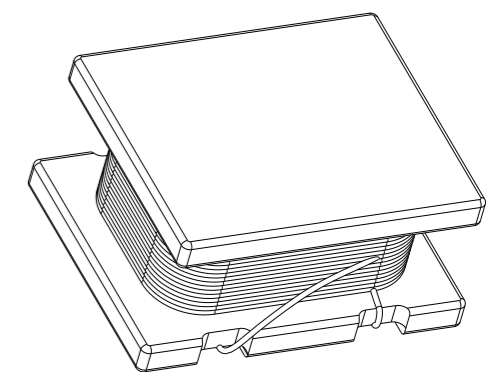

THIS DRAWING IS A CONTROLLED DOCUMENT.		DWN DHEERAJ M 18AUG2023
DIMENSIONS: mm		CHK TRACY G 18AUG2023
TOLERANCES UNLESS OTHERWISE SPECIFIED:		APVD ALLAN P 18AUG2023
0 PLC	±	PRODUCT SPEC
1 PLC	±	APPLICATION SPEC
2 PLC	±	WEIGHT
3 PLC	±-	CUSTOMER DRAWING
4 PLC	±	SCALE
ANGLES	±	SHEET
FINISH	-	RESTRICTED TO
MATERIAL	-	REV
	-	



NAME
MINIATURE SMD POWER INDUCTOR
TYPE 3627 322515 SERIES

SIZE A3	CAGE CODE 00779	DRAWING NO C=2176635	RESTRICTED TO -
SCALE 20:1		SHEET 1 OF 2	REV BA1

REVISIONS

P	LTR	DESCRIPTION	DATE	DWN	APVD
-		SEE SHEET 1	-	-	-

SCHEDULE

TCPN	CATALOGUE NUMBER	PART DESCRIPTION	PART STATUS
2176635-1	36273225151R0N	3627 322515 1R0 30%	PRODUCTION
2176635-2	36273225151R5N	3627 322515 1R5 30%	PRODUCTION
2176635-3	36273225152R2M	3627 322515 2R2 20%	PRODUCTION
2176635-4	36273225153R3M	3627 322515 3R3 20%	PRODUCTION
2176635-5	36273225154R7M	3627 322515 4R7 20%	PRODUCTION
2176635-6	3627322515100K	3627 322515 10UH 10%	PRODUCTION
2176635-7	3627322515150K	3627 322515 15UH 10%	PRODUCTION
2176635-8	3627322515220K	3627 322515 22UH 10%	PRODUCTION
2176635-9	3627322515330K	3627 322515 33UH 10%	PRODUCTION
1-2176635-0	3627322515470K	3627 322515 47UH 10%	PRODUCTION
1-2176635-1	3627322515680K	3627 322515 68UH 10%	PRODUCTION
1-2176635-2	3627322515101K	3627 322515 100UH 10%	PRODUCTION

THIS DRAWING IS A CONTROLLED DOCUMENT.

DIMENSIONS:
mm

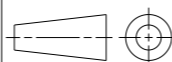

TOLERANCES UNLESS OTHERWISE SPECIFIED:

- 0 PLC ±-
- 1 PLC ±-
- 2 PLC ±-
- 3 PLC ±-
- 4 PLC ±-
- ANGLES ±

MATERIAL

-

FINISH

-

DWN 18AUG2023

DHEERAJ M

CHK 18AUG2023

TRACY G

APVD 18AUG2023

ALLAN P

PRODUCT SPEC

-

APPLICATION SPEC

-

WEIGHT

-

CUSTOMER DRAWING



TE Connectivity

NAME
MINIATURE SMD POWER INDUCTOR
TYPE 3627 322515 SERIES

SIZE CAGE CODE DRAWING NO RESTRICTED TO

A3 00779 C=2176635

SCALE 1:1 SHEET 2 OF 2 REV BA1