

THIS DRAWING IS UNPUBLISHED. RELEASED FOR PUBLICATION  
 © COPYRIGHT - By - ALL RIGHTS RESERVED.

REVISIONS					
P	LTR	DESCRIPTION	DATE	DWN	APVD
	A1	Add Customer P/N to 1-21995498-7	17APR2020	SJ	JH

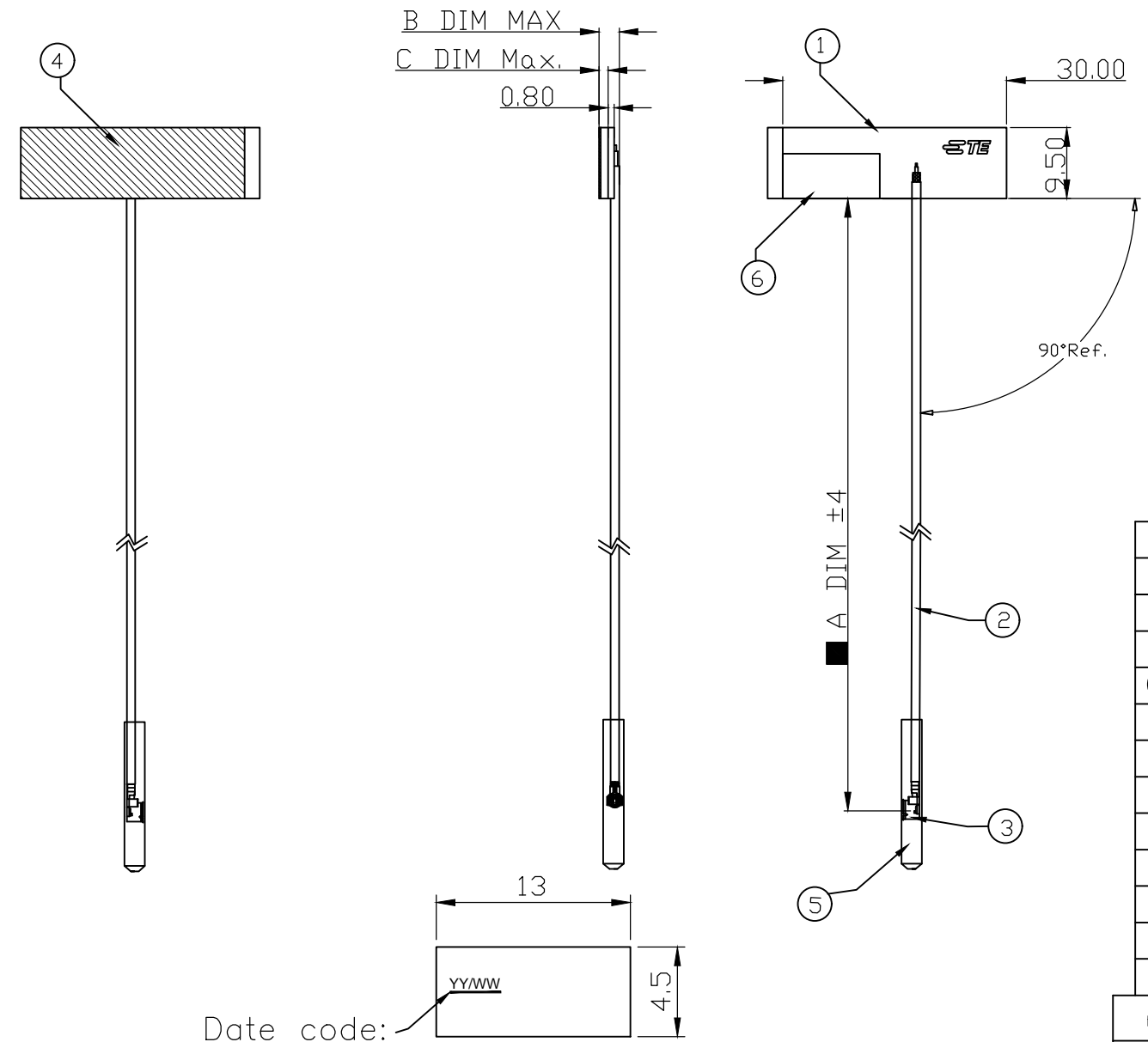

Date code: YYWW  
 YY: YEAR  
 WW: WEEK  
 LABEL SCALE 2:1

- NOTES:
- MATERIAL: SEE TABLE.
  - PRODUCT AND PROCESSING MUST MEET REQUIREMENTS OF TEC-138-702.

- LEGEND:
- = CRITICAL DIM.
  - = TOOLING DIM.
  - ▲ = PROCESS DIM.
  - ⊗ = DIMENSION ID

C DIM	B DIM	A DIM	CABLE COLOR	CABLE OD	CONN.	CUSTOMER P/N	TE P/N
1.2mm	3.5mm	330mm	BLACK	1.13mm	20278-112R-13	T710300022500	1-2195498-3
1.2mm	3.5mm	270mm	GRAY	1.13mm	20278-112R-13	T710300022600	1-2195498-2
0.8mm	3.1mm	30mm	GRAY	1.13mm	20278-112R-13	T690800010500	1-2195498-5
1.2mm	3.5mm	410mm	GRAY	1.13mm	20565-001R-13	TBD	2195498-8
1.2mm	3.5mm	900mm	GRAY	1.13mm	20565-001R-13	TBD	2195498-7
1.2mm	3.5mm	850mm	GRAY	1.13mm	20565-001R-13	TBD	2195498-6
1.2mm	3.5mm	120mm	GRAY	1.13mm	20565-001R-13	T690800007200	2195498-5
1.2mm	3.5mm	200mm	GRAY	1.13mm	20565-001R-13	T690800007300	2195498-4
1.2mm	3.5mm	350mm	GRAY	1.37mm	20351-112R-37	TBD	2195498-3
1.2mm	3.5mm	230mm	GRAY	1.37mm	20351-112R-37	TBD	2195498-2
		860mm	GRAY	1.37mm	20351-112R-37	TBD	2195498-1

ITEM	NAME	SPECIFICATION	QTY.
6	LABEL	LABEL, 13x4.5mm	1
5	TUBE	PE, PENETRABILITY, L:15mm.	1
4	SPONGE	SPONGE with DOUBLE SIDE ADHESIVE TAPE, SIZE:30(L)*9.5(W)*SEE TABLE(T)mm	1
3	CONN,	I-PEX SEE TABLE 1 CONN OR TE ENGINEER APPROVE	1
2	CABLE	COAXIAL CABLE, OD:SEE TABLE 1, COLOR:SEE TABLE1,NORMAL.	1
1	PCB	WLAN ANTENNA, SINGLE LAYER, FR-4, T=0.8mm,TE:2195487-1	1

THIS DRAWING IS A CONTROLLED DOCUMENT.		DWN Bill wu 18May17	TE Connectivity Ltd.	
		CHK ARES HUANG 18May17		
		APVD RICHARD GONG 18May17	NAME	
		PRODUCT SPEC	WIFI AND BT ANTENNA ASSEMBLY	
		APPLICATION SPEC		
		WEIGHT -	SIZE A3	CAGE CODE 10
			DRAWING NO C-2195498	
			RESTRICTED TO -	
		CUSTOMER DRAWING		SCALE 1:1
				SHEET 1 OF 4
				REV A1

DIMENSIONS: mm	TOLERANCES UNLESS OTHERWISE SPECIFIED:
	0 PLC ± -
	1 PLC ± 0.2
	2 PLC ± 0.10
	3 PLC ± 0.05
	4 PLC ± -
ANGLES	± 0.5°
MATERIAL -	FINISH -

THIS DRAWING IS UNPUBLISHED. RELEASED FOR PUBLICATION  
 © COPYRIGHT - By - ALL RIGHTS RESERVED.

REVISIONS					
P	LTR	DESCRIPTION	DATE	DWN	APVD
-	-	SEE SHEET 1	-	-	-

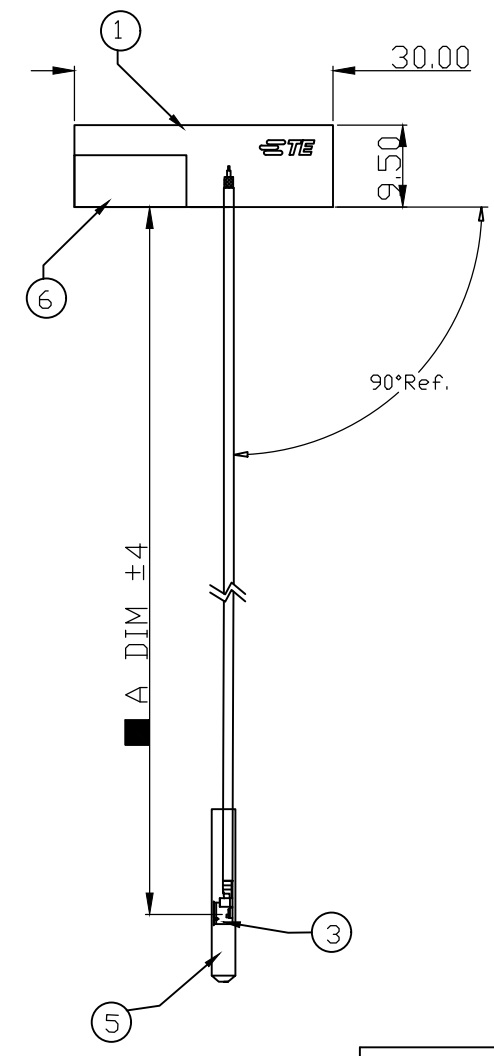
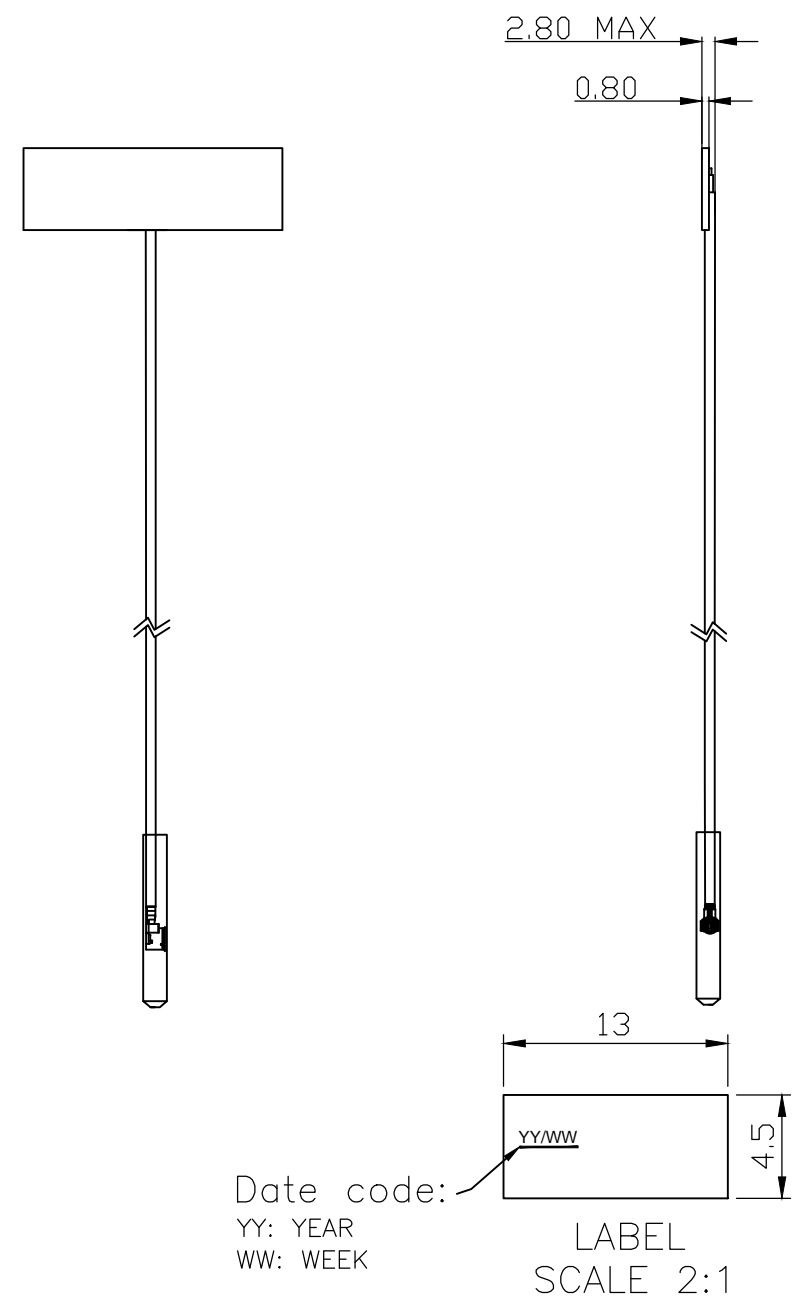

AS SHOWN : 2195498-9

- NOTES:  
 1. MATERIAL: SEE TABLE.  
 2. PRODUCT AND PROCESSING MUST MEET REQUIREMENTS OF TEC-138-702.

TABLE 1					
A DIM	CABLE COLOR	CABLE OD	CONN.	CUSTOMER P/N	TE P/N
170mm	GRAY	1.13mm	20278-112R-13	T690800009700	2195498-9

ITEM	NAME	SPECIFICATION	QTY.
6	LABEL	LABEL, 13x4.5mm	1
5	TUBE	PE, PENETRABILITY, L:15mm.	1
3	CONN,	I-PEX SEE TABLE 1 CONN OR TE ENGINEER APPROVE	1
2	CABLE	COAXIAL CABLE, OD:SEE TABLE 1, COLOR:SEE TABLE1,NORMAL.	1
1	PCB	WLAN ANTENNA, SINGLE LAYER, FR-4, T=0.8mm,TE:2195487-1	1

- LEGEND:  
 ■ = CRITICAL DIM.  
 ● = TOOLING DIM.  
 ▲ = PROCESS DIM.  
 (xx) = DIMENSION ID

THIS DRAWING IS A CONTROLLED DOCUMENT.		DWN Bill wu 18May17	TE Connectivity Ltd. NAME WIFI AND BT ANTENNA ASSEMBLY		
DIMENSIONS: mm		CHK ARES HUANG 18May17			
TOLERANCES UNLESS OTHERWISE SPECIFIED:		APVD RICHARD GONG 18May17	RESTRICTED TO		
0 PLC ± - 1 PLC ± 0.2 2 PLC ± 0.10 3 PLC ± 0.05 4 PLC ± - ANGLES ± 0.5°		PRODUCT SPEC	SIZE A3	CAGE CODE 23	DRAWING NO C-2195498
MATERIAL		FINISH	WEIGHT	SCALE 1:1	
CUSTOMER DRAWING			SHEET 2 OF 4		REV A1

THIS DRAWING IS UNPUBLISHED.

RELEASED FOR PUBLICATION

REVISIONS

© COPYRIGHT - By -

ALL RIGHTS RESERVED.

P	LTR	DESCRIPTION	DATE	DWN	APVD
-	-	SEE SHEET 1	-	-	-

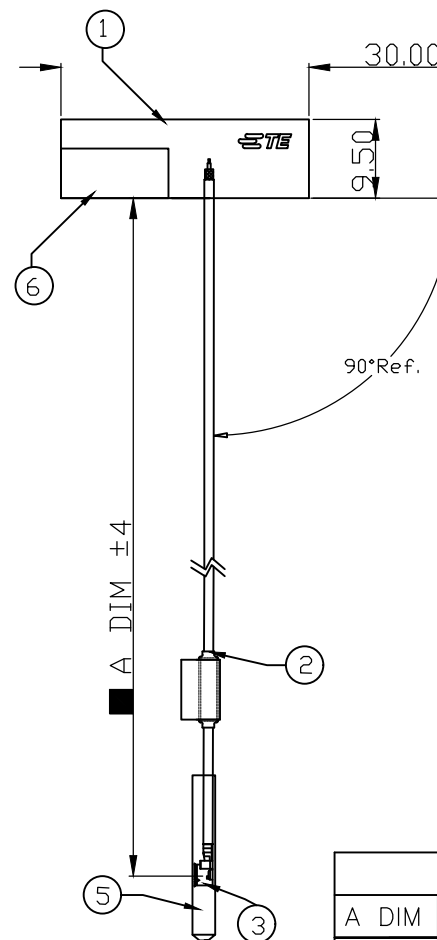
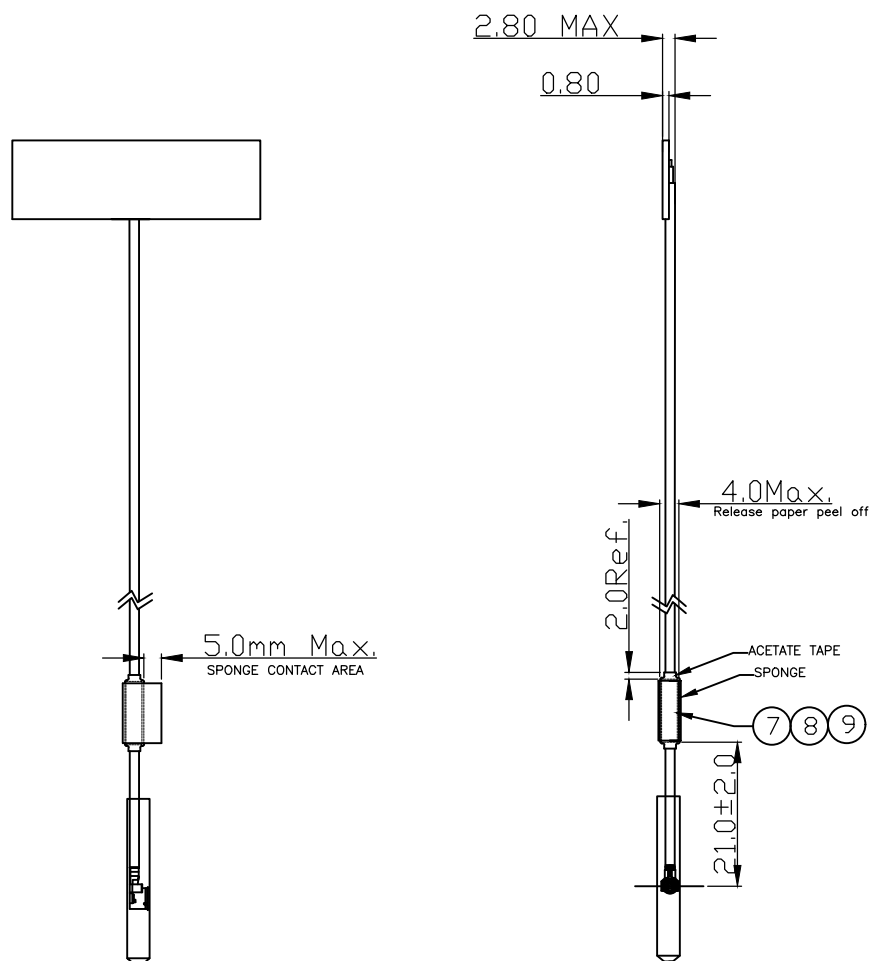

AS SHOWN : 1-2195498-4

A DIM	CABLE COLOR	CABLE OD	CONN.	CUSTOMER P/N	TE P/N
170mm	GRAY	1.13mm	20278-112R-13	T690800010600	1-2195498-4

ITEM	NAME	SPECIFICATION	QTY.
9	SPONGE	SPONGE with DOUBLE SIDE ADHESIVE TAPE, SIZE:9.0mm(L)*13.0mm(W)Ref.*1.0(T)mm	1
8	ACETATE TAPE	ACETATE TAPE.	1
7	Ferrite	SIZE:4.0mm*10.0mm.	1
6	LABEL	LABEL, 13x4.5mm	1
5	TUBE	PE, PENETRABILITY, L:15mm.	1
3	CONN,	I-PEX SEE TABLE 1 CONN OR TE ENGINEER APPROVE	1
2	CABLE	COAXIAL CABLE, OD:SEE TABLE 1, COLOR:SEE TABLE1,NORMAL.	1
1	PCB	WLAN ANTENNA, SINGLE LAYER, FR-4, T=0.8mm,TE:2195487-1	1

NOTES:

- 1. MATERIAL: SEE TABLE.
- 2. PRODUCT AND PROCESSING MUST MEET REQUIREMENTS OF TEC-138-702.

Date code: YY/WW  
 YY: YEAR  
 WW: WEEK

LABEL  
 SCALE 2:1

LEGEND:

- = CRITICAL DIM.
- = TOOLING DIM.
- ▲ = PROCESS DIM.
- ⊗ = DIMENSION ID

THIS DRAWING IS A CONTROLLED DOCUMENT.		DWN Bill wu 18May17	TE Connectivity Ltd.		
DIMENSIONS: mm		CHK ARES HUANG 18May17			
TOLERANCES UNLESS OTHERWISE SPECIFIED:		APVD RICHARD GONG 18May17	NAME WIFI AND BT ANTENNA ASSEMBLY		
0 PLC ± - 1 PLC ± 0.2 2 PLC ± 0.10 3 PLC ± 0.05 4 PLC ± - ANGLES ± 0.5°		PRODUCT SPEC -	-		
MATERIAL		APPLICATION SPEC -	SIZE A3	CAGE CODE 00779	DRAWING NO C-2195498
FINISH -		WEIGHT -	RESTRICTED TO -		SCALE 1:1
CUSTOMER DRAWING			SHEET 3 OF 4	REV A1	

THIS DRAWING IS UNPUBLISHED.

RELEASED FOR PUBLICATION

REVISIONS

© COPYRIGHT - By -

ALL RIGHTS RESERVED.

P	LTR	DESCRIPTION	DATE	DWN	APVD
-	-	SEE SHEET 1	-	-	-

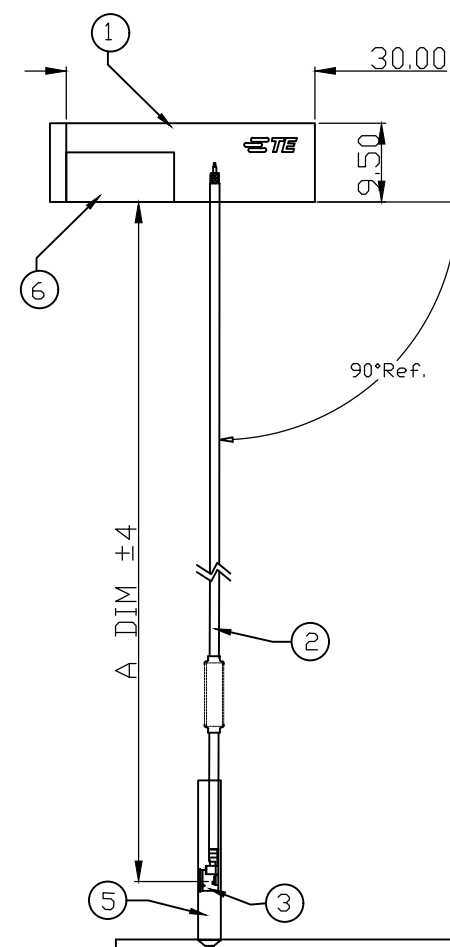
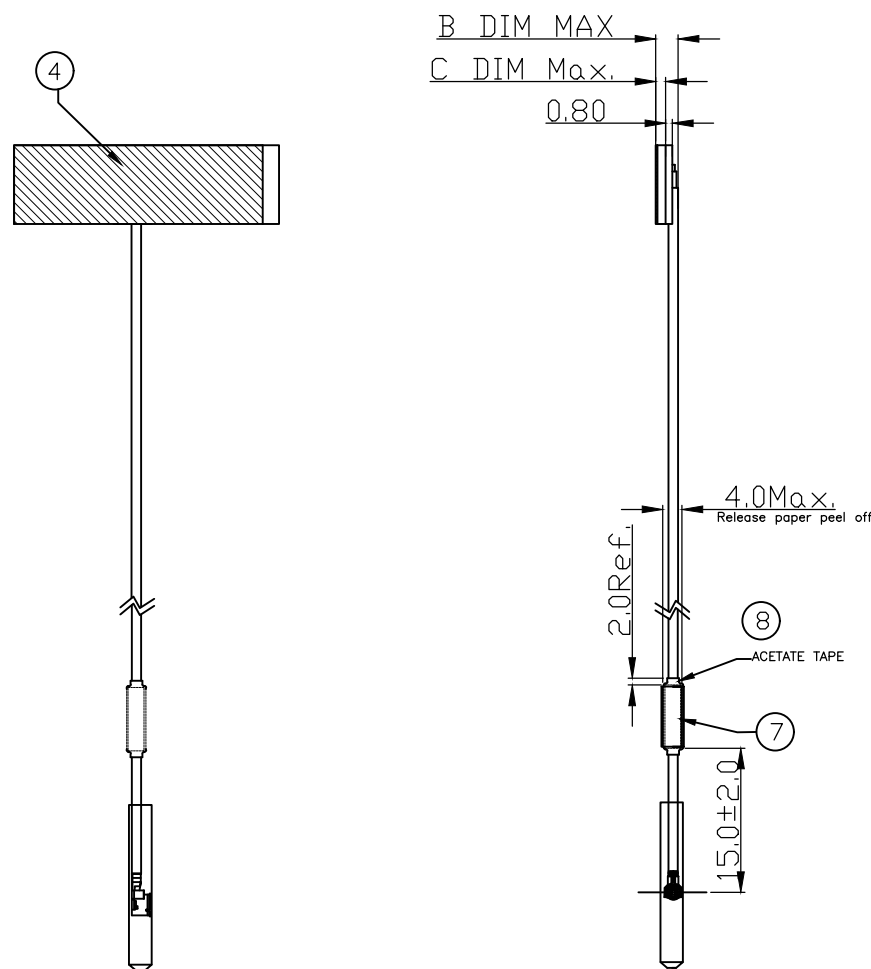

AS SHOWN : 1-2195498-7

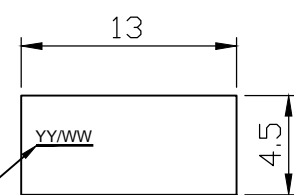

Date code:  
YY: YEAR  
WW: WEEK

LABEL  
SCALE 2:1

NOTES:

1. MATERIAL: SEE TABLE.
2. PRODUCT AND PROCESSING MUST MEET REQUIREMENTS OF TEC-138-702.
3. PACKAGING: VACUUM PACKED, BAGGED OR SHRINK WRAPPED IN BULK.

C DIM	B DIM	A DIM	CABLE COLOR	CABLE OD	CONNECTOR	CUSTOMER P/N	TE P/N
1.2mm	3.5mm	150mm	GRAY	1.13mm	20278-112R-13	88842	1-2195498-7

ITEM	NAME	SPECIFICATION	QTY.
⑧	ACETATE TAPE	ACETATE TAPE.	1
⑦	FERRITE	SIZE:4.0mm*10.0mm.	1
⑥	LABEL	LABEL, 13x4.5mm	1
⑤	TUBE	PE, PENETRABILITY, L:15mm.	1
④	SPONGE	SPONGE with DOUBLE SIDE ADHESIVE TAPE, SIZE:30(L)*9.5(W)*SEE TABLE(T)mm	1
③	CONNECTOR	I-PEX 20278-112R-13	1
②	CABLE	COAXIAL CABLE, OD:SEE TABLE 1, COLOR:SEE TABLE1,NORMAL.	1
①	PCB	WLAN ANTENNA, SINGLE LAYER, FR-4, T=0.8mm,TE:2195487-1	1

LEGEND:

- = CRITICAL DIM.
- = TOOLING DIM.
- ▲ = PROCESS DIM.
- ⊗ = DIMENSION ID

THIS DRAWING IS A CONTROLLED DOCUMENT.		DWN Bill wu 18May17	<b>TE Connectivity Ltd.</b>  NAME <b>WIFI AND BT ANTENNA ASSEMBLY</b>											
DIMENSIONS: mm		CHK ARES HUANG 18May17												
TOLERANCES UNLESS OTHERWISE SPECIFIED:		APVD RICHARD GONG 18May17												
<table border="0"> <tr> <td>0 PLC</td><td>± -</td> </tr> <tr> <td>1 PLC</td><td>± 0.2</td> </tr> <tr> <td>2 PLC</td><td>± 0.10</td> </tr> <tr> <td>3 PLC</td><td>± 0.05</td> </tr> <tr> <td>4 PLC</td><td>± -</td> </tr> <tr> <td>ANGLES</td><td>± 0.5°</td> </tr> </table>		0 PLC				± -	1 PLC	± 0.2	2 PLC	± 0.10	3 PLC	± 0.05	4 PLC	± -
0 PLC	± -													
1 PLC	± 0.2													
2 PLC	± 0.10													
3 PLC	± 0.05													
4 PLC	± -													
ANGLES	± 0.5°													
MATERIAL -	FINISH -	APPLICATION SPEC -	SIZE A3	CAGE CODE 00779	DRAWING NO C-2195498	RESTRICTED TO -								
CUSTOMER DRAWING			SCALE 1:1	SHEET 4 OF 4	REV A1									