

REVISIONS				
P.	LTN	DESCRIPTION	DATE	APPROV
A2		REVISED PER ECO-15-011290	05AUG2015	MK MB
B		REVISED PER ECO-16-009324	07NOV2016	DD JT

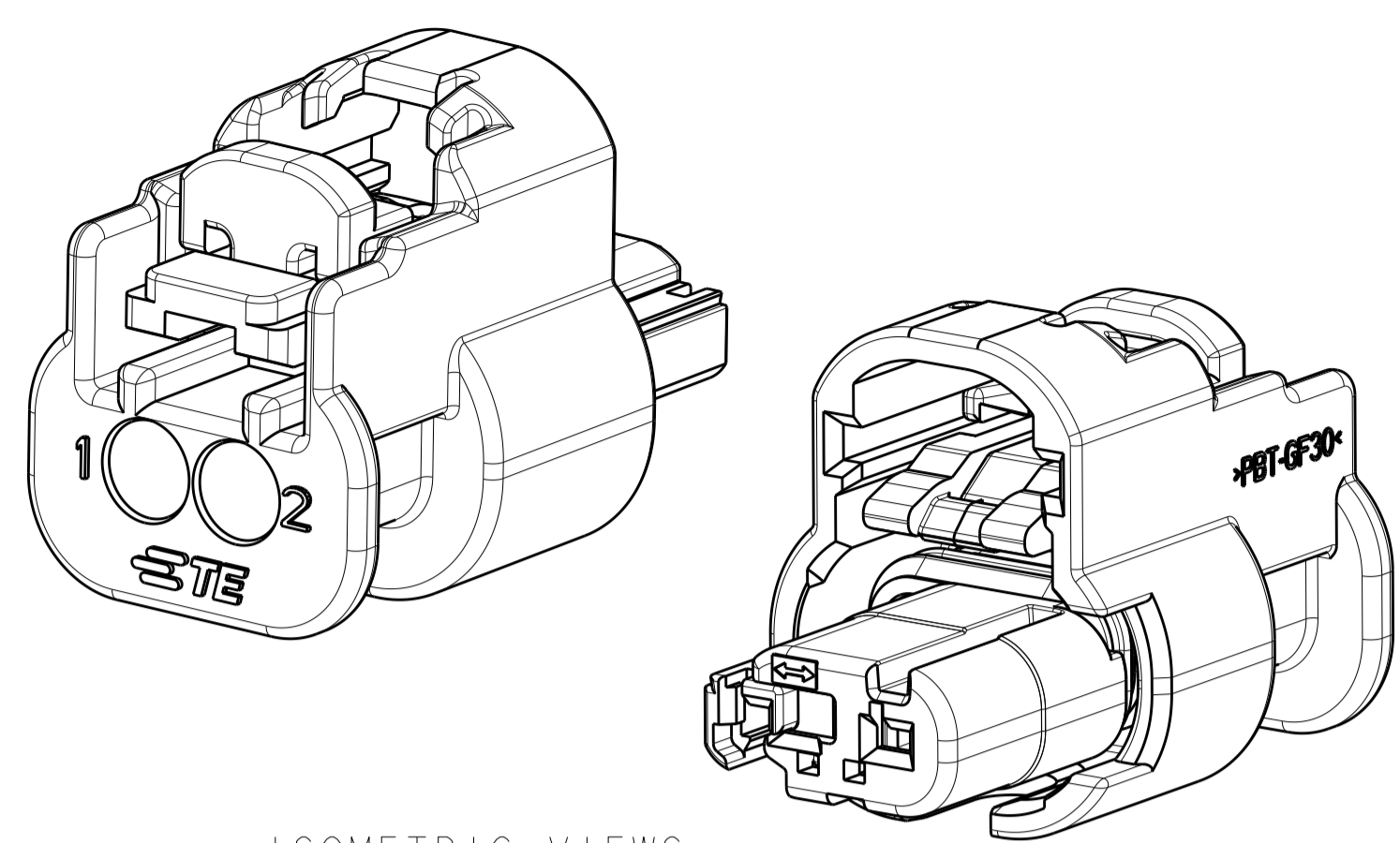

ISOMETRIC VIEWS
SCALE 4:1

1. ISL AND CPA (WHEN APPLICABLE) ARE SHIPPED IN THEIR PRE-LATCHED POSITIONS.
2. TERMINALS SOLD SEPARATELY. FOR USE WITH TE MCON 1.2mm CLEAN BODY CONTACT WITH WIRE SEAL. SEE TABLE.
3. APPLICABLE INTERFACE DRAWINGS: EWCAP 120-S-002-1-Z01 AND 120-S-002-1-Z02.
4. MINIMUM FEED THROUGH CONDITION WITH 1.0mm CLEARANCE ALL AROUND.
5. TRACEABILITY CODE (YY = TWO DIGIT YEAR, JJJ = 3 DIGIT JULIAN DAY, S = 1 DIGIT SHIFT).
6. FOR OPTIONAL TERMINAL CAVITY BLOCKING, CONTACT TE SALES REPRESENTATIVE OR CUSTOMER SERVICE.
7. SEE INSTRUCTION SHEET 408-32103 FOR CONNECTOR SERVICE AND ISL OPERATION. ISL ACTUATION DISTANCE IS 2.0mm.
8. CONTACT PLATING AND APPLICABLE INDIVIDUAL WIRE SEAL ARE APPLICATION DEPENDENT. CONTACT TE SALES REPRESENTATIVE OR CUSTOMER SERVICE FOR DETAILS.
9. FOR WIRE CRIMP DETAILS, SEE TE APPLICATION SPECIFICATION 114-18464.
10. DOCUMENTED I.C.D. IS SPECIFIED TO MEET MOST WIRE SEAL APPLICATIONS. HOWEVER, I.C.D. IS HIGHLY DEPENDENT ON INSULATION TYPE AND OD. SUFFICIENT GRIP OF THE WIRE SEAL MUST BE OBTAINED SUCH THAT WIRE SEAL DOES NOT DISPLACE FROM INSULATION GRIP DURING CONTACT INSERTION INTO CONNECTOR HOUSING. THE WIRE SEAL SHALL NOT BE CRIMPED TOO TIGHTLY THAT THE WIRE SEAL TEARS DURING THE CRIMPING OPERATION.
11. CONNECTOR VALIDATION PER USCAR-2 (REV 6) T4,V4,S3.
12. KEY CODE DIMENSIONS ARE SHOWN WITH ISL IN PRE-LATCHED POSITION. FOR DIMENSION OF KEY WITH ISL IN FINAL POSITION, ADJUST SHOWN DIMENSIONS BY 2.0mm.
13. MATES WITH STRAIGHT EXIT WIRE DRESS, TE PN 2272168-1 AND RIGHT ANGLE EXIT WIRE DRESS, TE PN 2272169-1

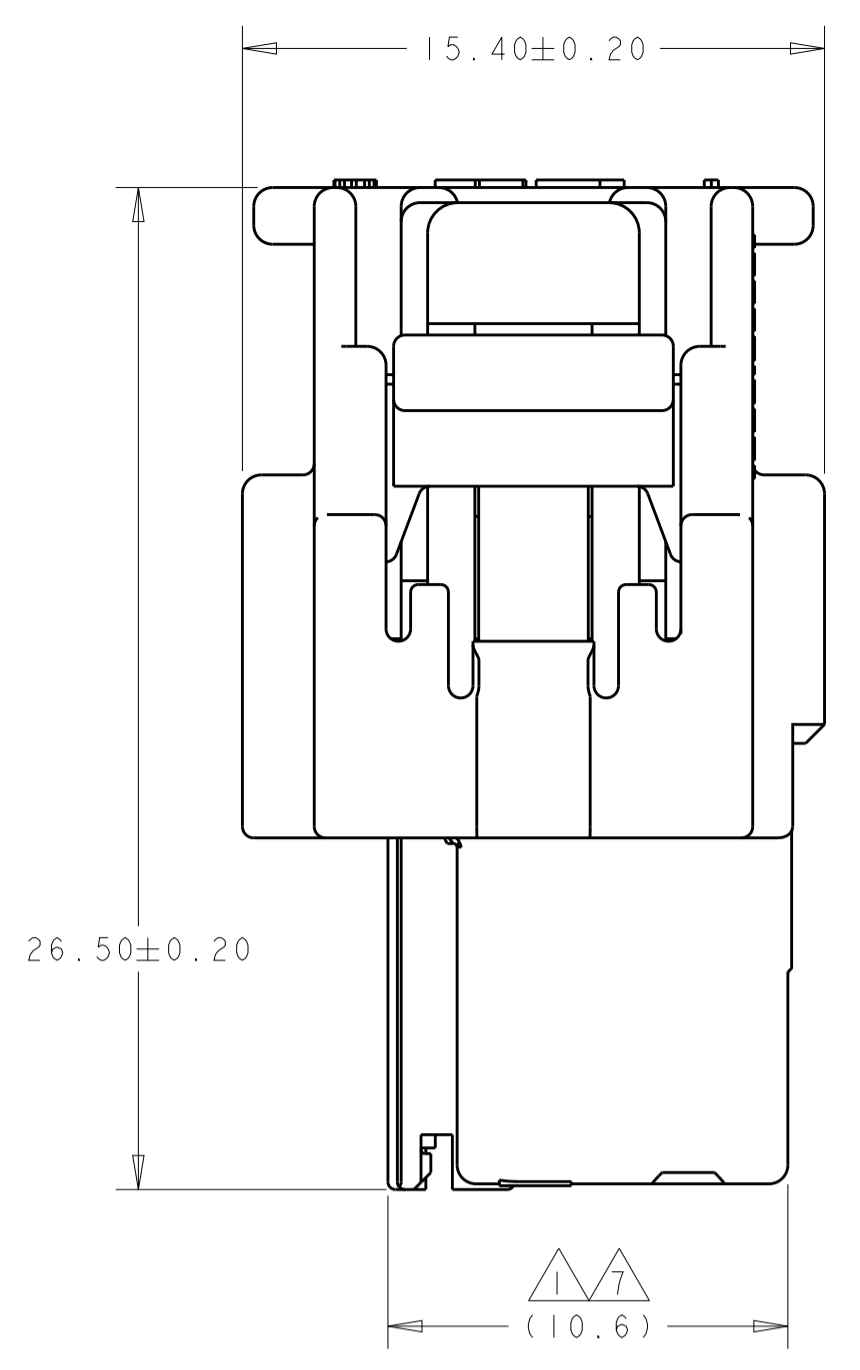
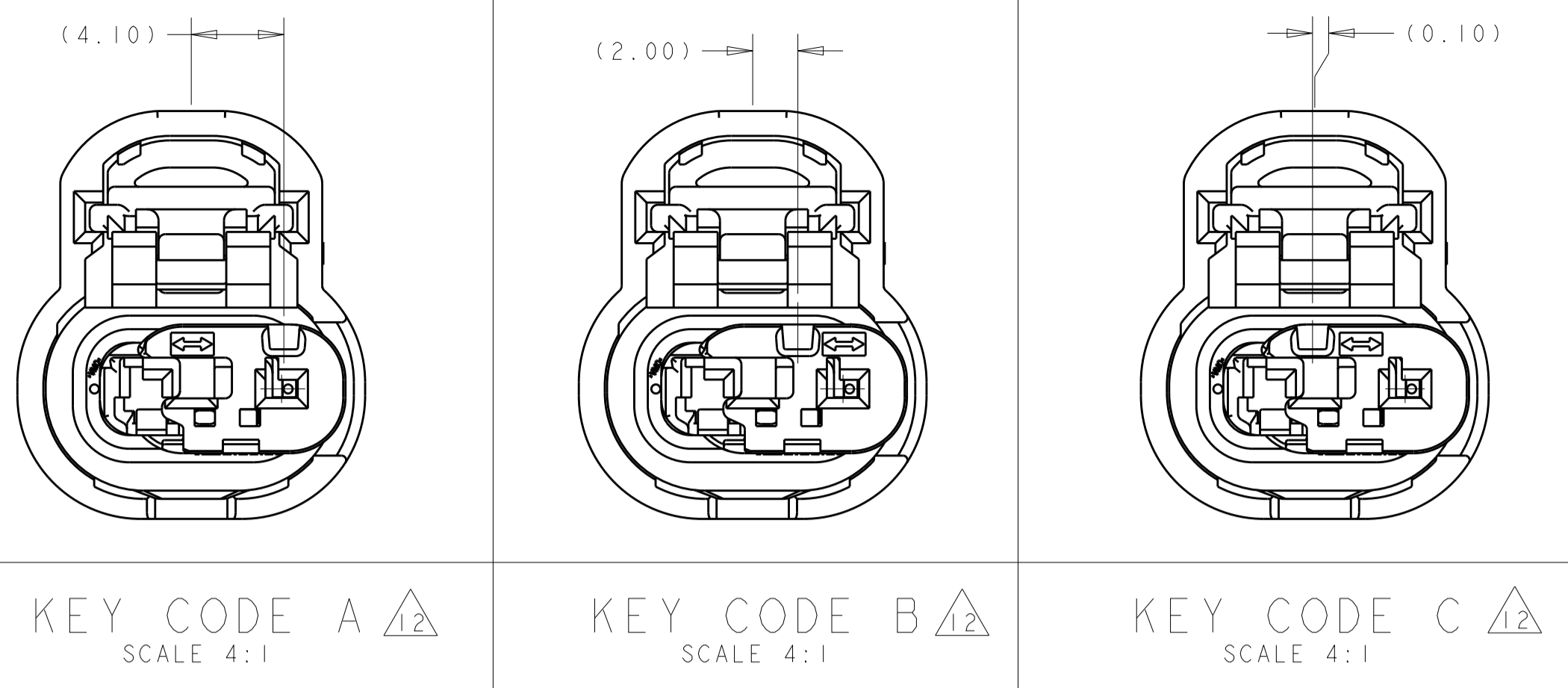
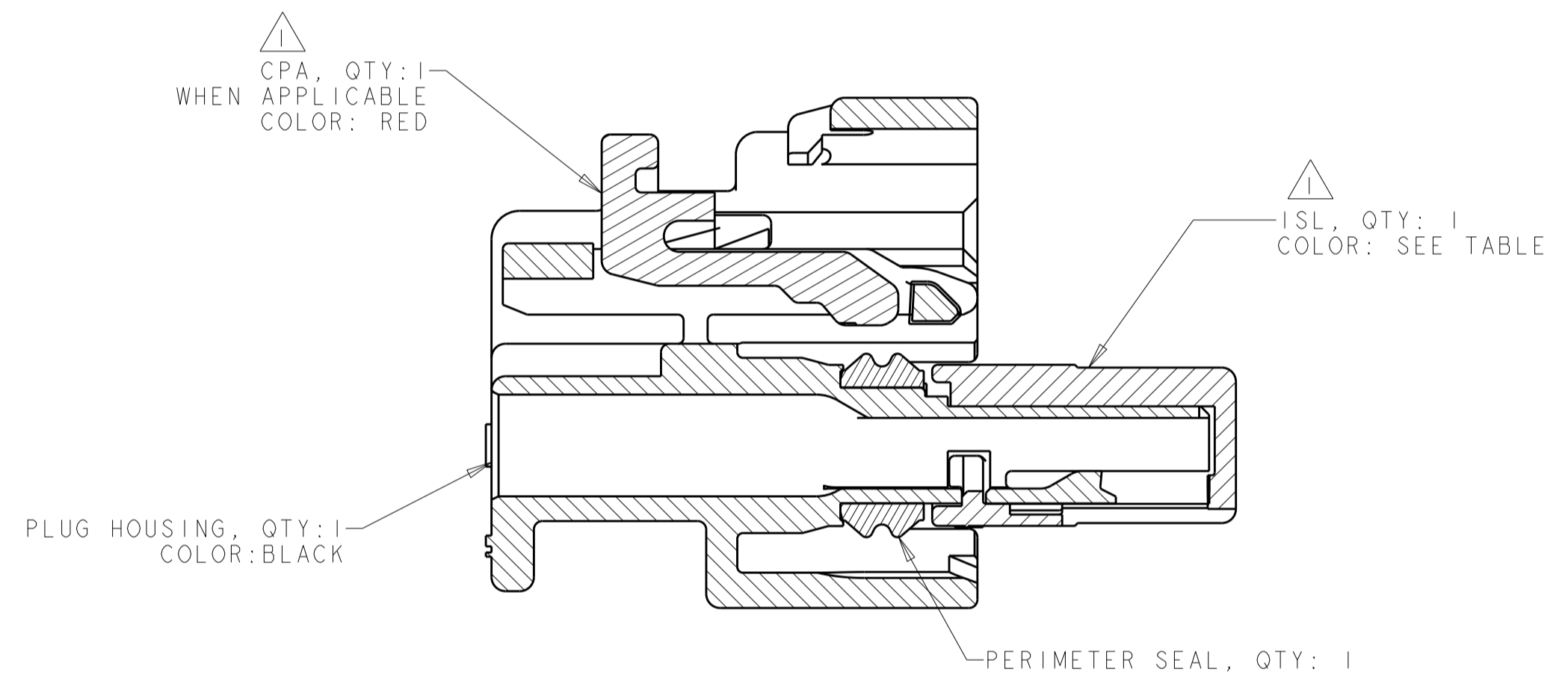

SECTION X-X
SHOWN WITH CPA AND ISL IN
PRE-LATCHED POSITION

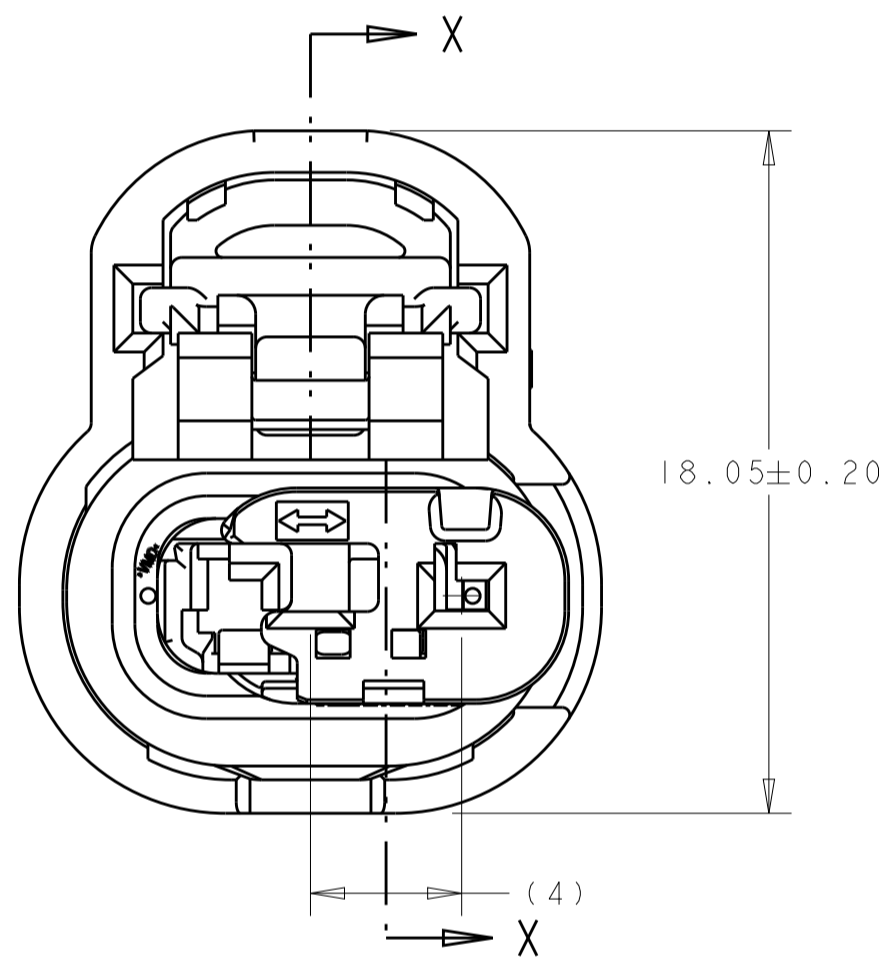

ISL SHOWN IN
PRE-LATCHED (AS-SHIPED) POSITION

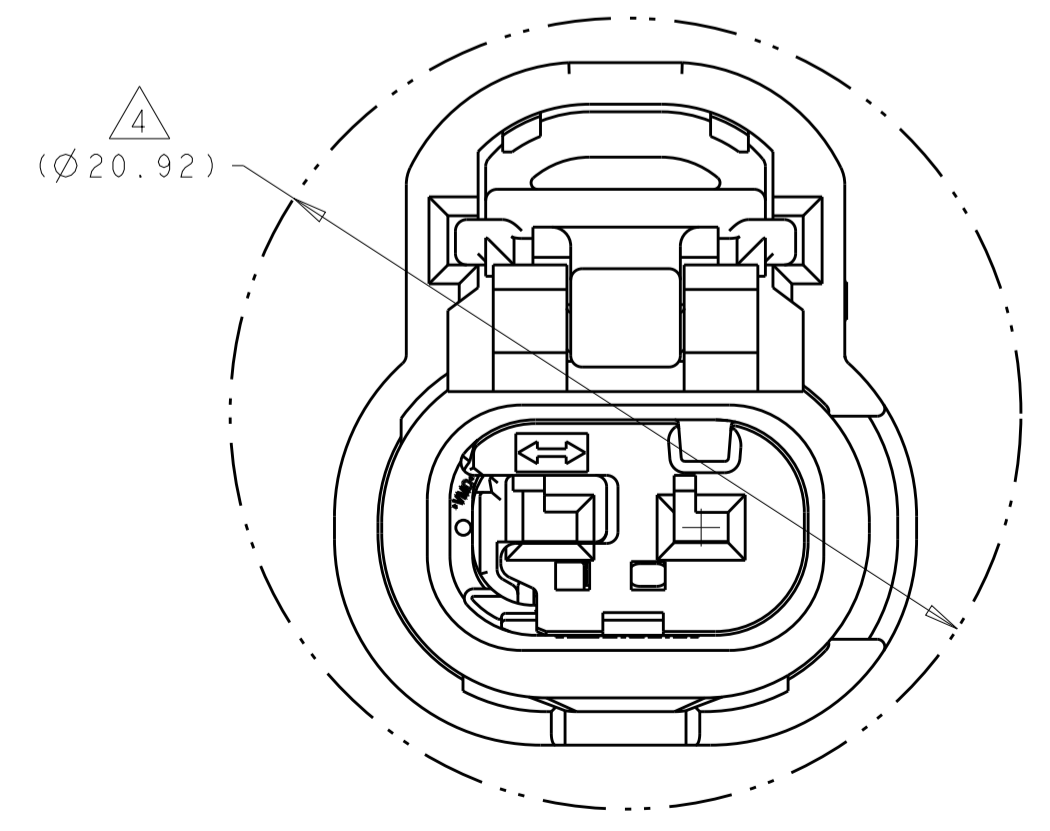

ISL SHOWN IN
FINAL (LOCKED) POSITION - REF ONLY
SCALE 5:1

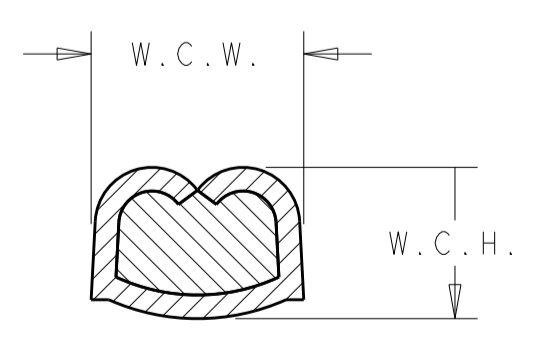

WIRE CRIMP
DIMENSIONS

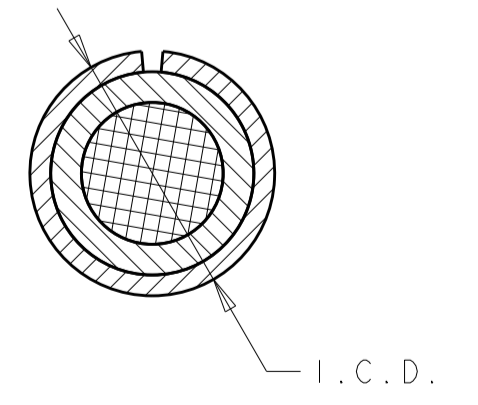

INSULATION CRIMP
DIMENSIONS

CPA (YES / NO)	ISL COLOR	KEY CONFIGURATION	PART NUMBER
YES	DK GRAY	KEY CODE C	1-2203769-3
YES	LT GRAY	KEY CODE B	1-2203769-2
YES	BLUE	KEY CODE A	1-2203769-1
NO	DK GRAY	KEY CODE C	2203769-3
NO	LT GRAY	KEY CODE B	2203769-2
NO	BLUE	KEY CODE A	2203769-1

150°C	1418844				
8	1670146	9	9	10	8
MAX TEMP	FEMALE TERMINAL P/N	W.C.H	W.C.W	I.C.D	WIRE SEAL PART NUMBER

THIS DRAWING IS A CONTROLLED DOCUMENT.

OWN: V. PATAGAR, 25MAR2013
 CHK: R. HETRICK, 25MAR2013
 APVD: R. HETRICK, 25MAR2013

NAME: PLUG ASSEMBLY, SEALED, 2 POSITION, MCON

PRODUCT SPEC: -
 APPLICATION SPEC: -
 WEIGHT: -
 CUSTOMER DRAWING: -

SIZE: A1
 CAGE CODE: -
 DRAWING NO: 2203769
 SCALE: 5:1

RESTRICTED TO: -
 SHEET: 1 OF 1
 REV: B