

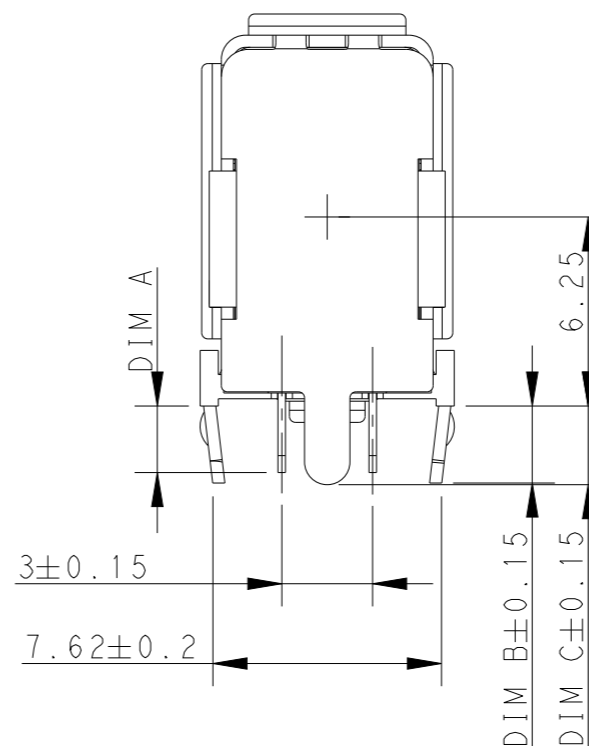

P	LTR	DESCRIPTION	DATE	DWN	APVD
	A2	ECR-14-008826	13JUL2014	HW	XX
	A3	ECR-16-006227	28APR2016	FY	XX
	A4	ECR-19-009366	13JUN2019	HH	CW
	A5	ECR-19-016271	18OCT2019	HH	CW

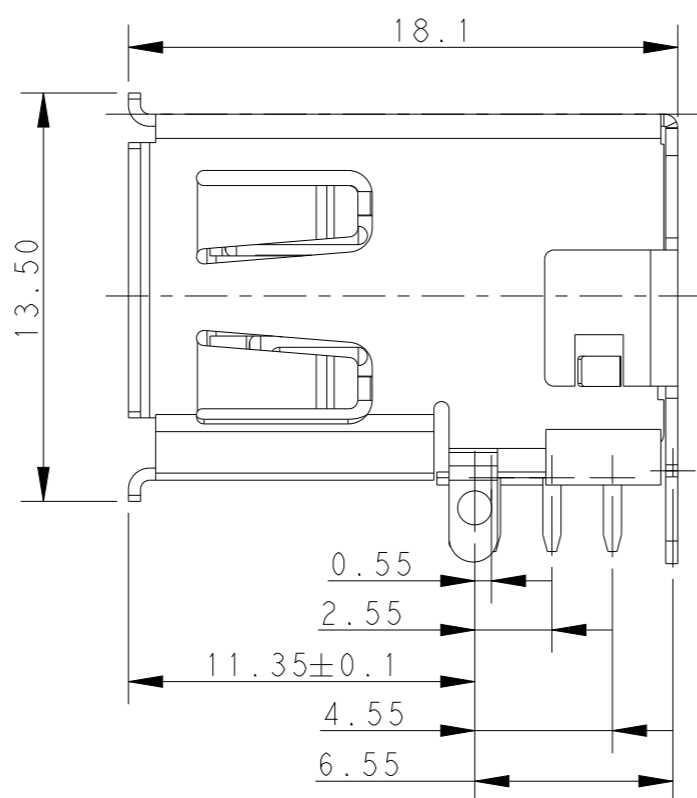
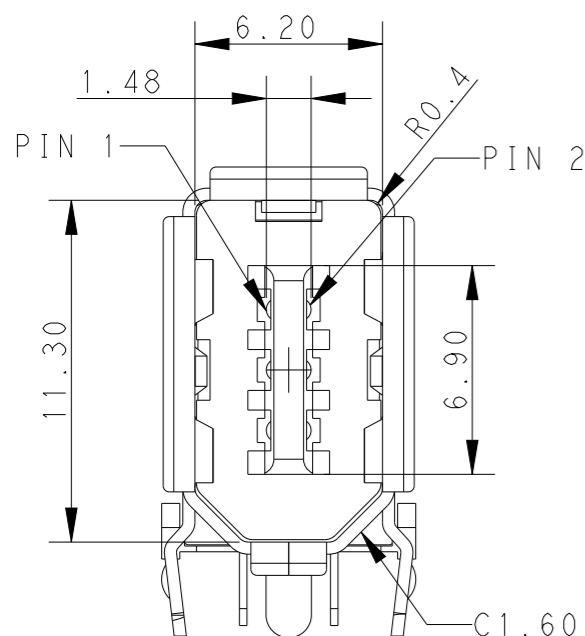
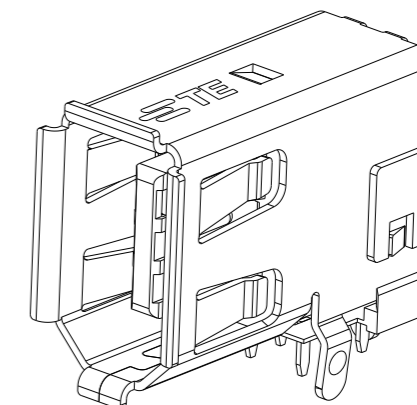
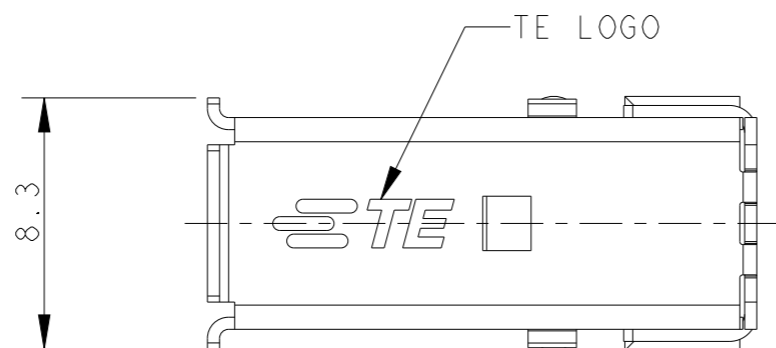

NOTE:

- MATERIAL:
HOUSING:PBT WITH 30% GF,BLACK COLOR
CONTACTS:BRASS
SHELL:PHOSPHOR BRONZE
- FINISH:
CONTACTS:0.75µm(30u")MIN.GOLD PLATED ON CONTACT AREA
2.54µm(100u") MIN.MATTE-TIN ON SOLDER TAIL,
WITH ENTIRE CONTACT UNDERPLATED
1.27µm(50u")MIN.NICKEL PLATED
SHELL:1.27µm(50u")MIN. BRIGHT-TIN PLATED OVER
1.27µm(50u")MIN. NICKEL PLATED
- WAVE SOLDER CAPABLE TO 265°C PER TE TEST SPEC 109-201.
, CONDITION B

2232261-2	2.20	2.60	2.60	108-106127
2232261-1	3.20	3.59	3.70	
PART NUMBER	DIM A	DIM B	DIM C	PRORUCT SPEC

THIS DRAWING IS A CONTROLLED DOCUMENT.		DWN 28APR2016 FENCER YU	 TE Connectivity	
DIMENSIONS: mm		CHK 28APR2016 KOBBY ZHAO		
TOLERANCES UNLESS OTHERWISE SPECIFIED:		APVD 28APR2016 XIANG XU	NAME 1394_A RECEPTACLE UP RIGHT R/A THRU HOLE TYPE	
0 PLC ±- 1 PLC ±0.3 2 PLC ±0.2 3 PLC ±- 4 PLC ±- ANGLES ±-		PRODUCT SPEC SEE TABLE	SIZE CAGE CODE DRAWING NO RESTRICTED TO	
MATERIAL SEE NOTE		APPLICATION SPEC -	A3 00779 C-2232261	
FINISH SEE NOTE		WEIGHT 3.17 g	SCALE 3:1 SHEET 1 OF 6 REV A5	
		CUSTOMER DRAWING		

4

3

2

1

THIS DRAWING IS UNPUBLISHED.

RELEASED FOR PUBLICATION

20

© COPYRIGHT 20 BY -

ALL RIGHTS RESERVED.

REVISIONS

P	LTR	DESCRIPTION	DATE	DWN	APVD
-	-	SEE SHEET 1	-	-	-

VIEW F

100pcs/Troy

315±1.0

230±1.0

NOTE:

1. PACKAGING MATERIAL IN PLASTIC, RUBBER, INK, PIGMENT AND PAINT MUST MEET CONTROLLED SUBSTANCES SPEC PER 230-702

1) CADMIUM AND CADMIUM COMPOUNDS NOT TO EXCEED: 5PPM

2) LEAD, CADMIUM, CHROM VI AND MERCURY NOT EXCEED: 100PPM (COMBINED)

28.7

20

VIEW F

THIS DRAWING IS A CONTROLLED DOCUMENT.

DWN 28APR2016

FENCER YU

CHK 28APR2016

KOBBY ZHAO

APVD 28APR2016

XIANG XU

PRODUCT SPEC

APPLICATION SPEC

-

WEIGHT

3.17 g

CUSTOMER DRAWING

TE Connectivity

NAME 1394_A RECEPTACLE UP RIGHT R/A THRU HOLE TYPE

SIZE	CAGE CODE	DRAWING NO	RESTRICTED TO
------	-----------	------------	---------------

A300779 C-2232261

SCALE	SHEET	OF	REV
3:1	2	6	A5

DIMENSIONS:

mm

TOLERANCES UNLESS OTHERWISE SPECIFIED:

0 PLC	±-
1 PLC	±0.3
2 PLC	±0.2
3 PLC	±-
4 PLC	±-
ANGLES	±-
FINISH	-

MATERIAL

SEE NOTE

FINISH

SEE NOTE

1470-19 (3/13)

P	LTR	DESCRIPTION	DATE	DWN	APVD
-	-	SEE SHEET 1	-	-	-

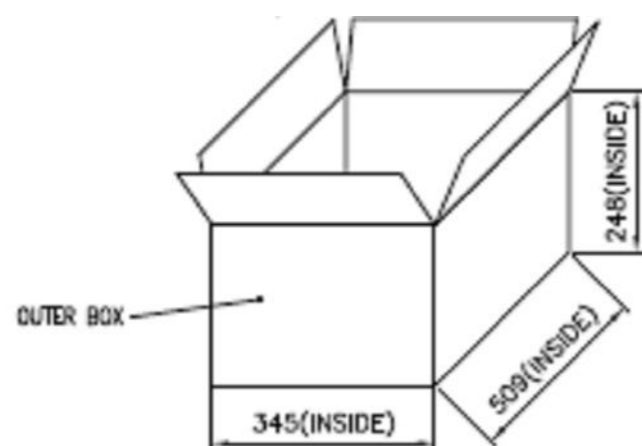
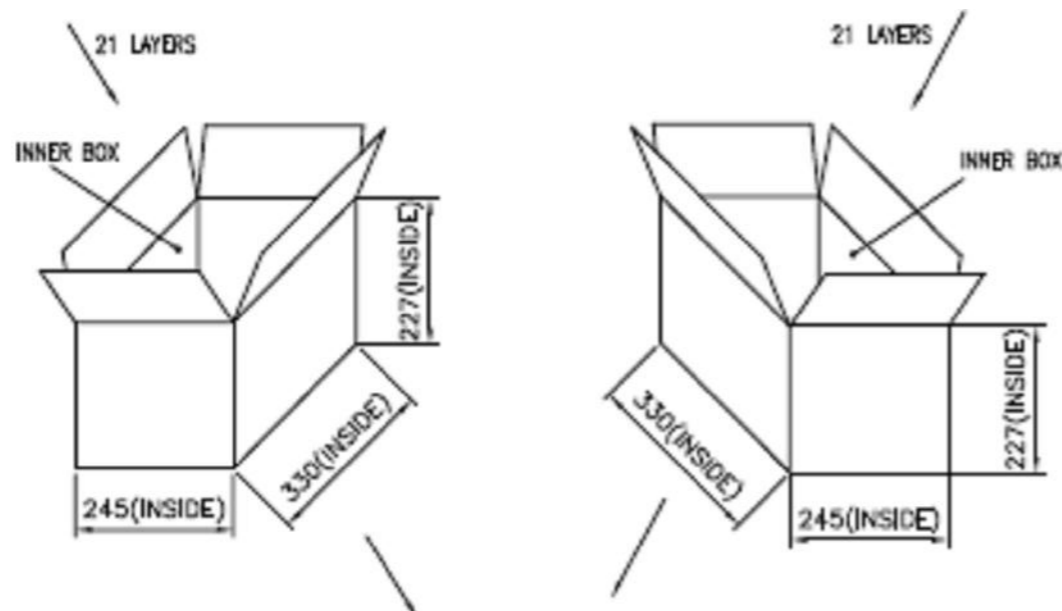
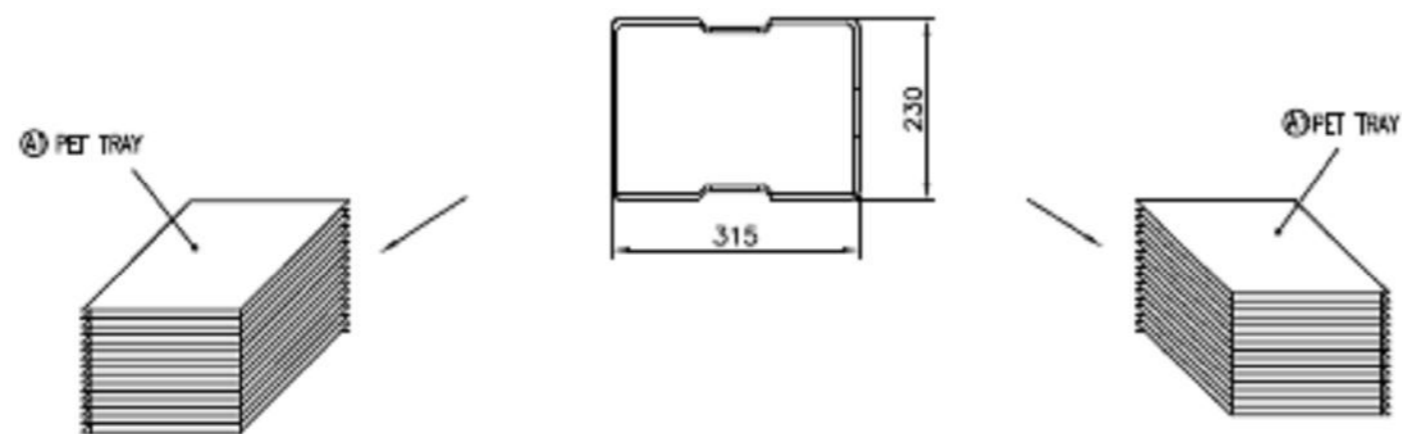

2232261-2	17.42Kg	13.32Kg	100	21	42	4200PCS
2232261-1	17.75Kg	13.65Kg	100	21	42	4200PCS
PART NUMBER	GROSS WEIGHT	NET WEIGHT	PCS/TRAY	TRAYS/ INNER BOX	TRATS /CARTON	QUANTITY

THIS DRAWING IS A CONTROLLED DOCUMENT.

DIMENSIONS: mm

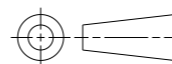

MATERIAL

SEE NOTE

TOLERANCES UNLESS OTHERWISE SPECIFIED:

- 0 PLC ±-
- 1 PLC ±0.3
- 2 PLC ±0.2
- 3 PLC ±-
- 4 PLC ±-
- ANGLES ±-
- FINISH ±-

SEE NOTE

DWN 28APR2016
FENCER YU
CHK 28APR2016
KOBBY ZHAO
APVD 28APR2016
XIANG XU

PRODUCT SPEC
SEE TABLE

APPLICATION SPEC

WEIGHT 3.17 g

CUSTOMER DRAWING



NAME 1394_A RECEPTACLE UP RIGHT R/A THRU HOLE TYPE

SIZE CAGE CODE DRAWING NO RESTRICTED TO

A300779 C-2232261

SCALE 3:1 SHEET 3 OF 6 REV A5

P	LTR	DESCRIPTION	DATE	DWN	APVD
-	-	SEE SHEET 1	-	-	-

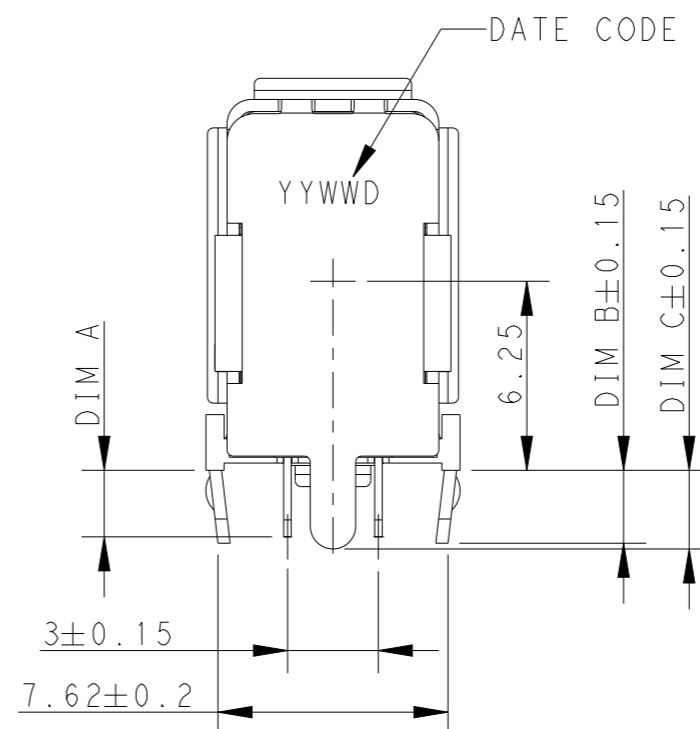
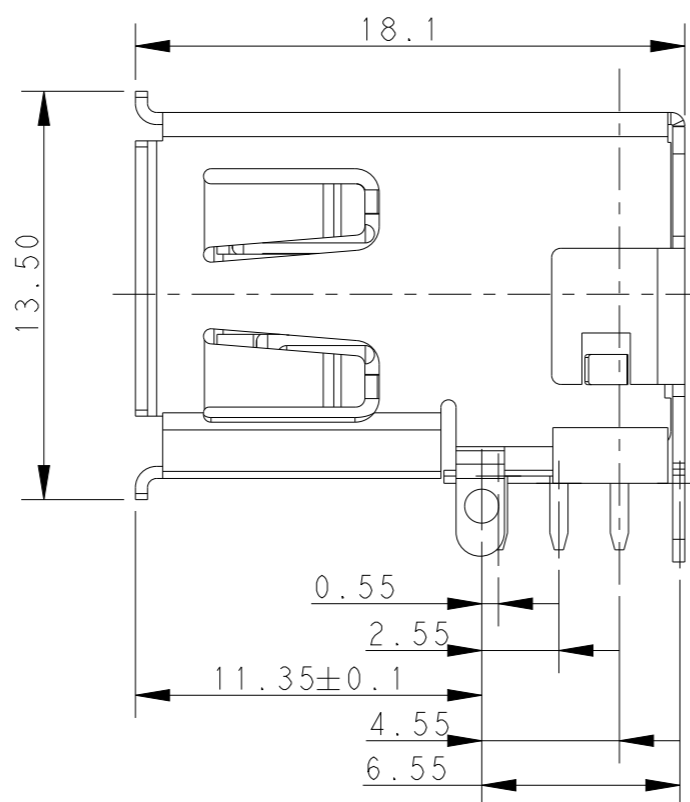
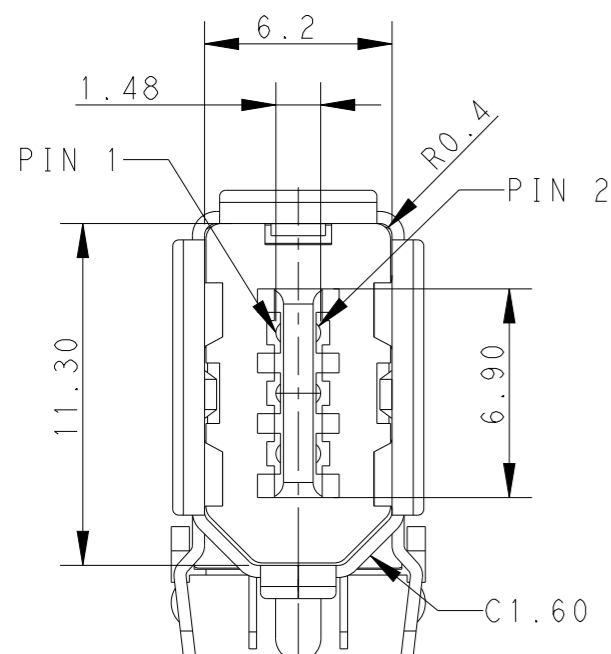
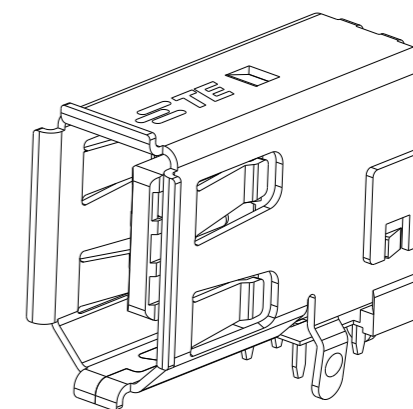
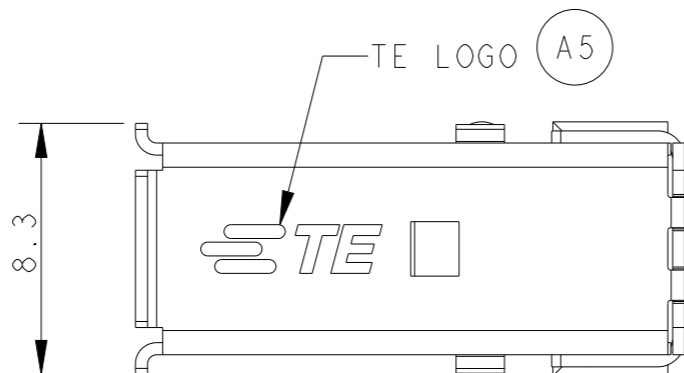

NOTE:

- MATERIAL:
HOUSING: PA9T WITH 33% GF, BLACK COLOR
CONTACTS: BRASS
SHELL: PHOSPHOR BRONZE
- FINISH:
CONTACTS: 0.75µm(30u") MIN. GOLD PLATED ON CONTACT AREA
2.54µm(100u") MIN. MATTE-TIN ON SOLDER TAIL,
WITH ENTIRE CONTACT UNDERPLATED
1.27µm(50u") MIN. NICKEL PLATED
SHELL: 1.27µm(50u") MIN. MATTE TIN PLATED OVER
1.27µm(50u") MIN. NICKEL PLATED
- REFLOW SOLDER CAPABLE TO 260°C MAX PER TE SPEC109-201.
- DATE CODE: YYWWD(YY: YEAR WW: WEEK D:DAY)

THIS DRAWING IS A CONTROLLED DOCUMENT.

DIMENSIONS: mm	TOLERANCES UNLESS OTHERWISE SPECIFIED:
	0 PLC ±-
	1 PLC ±0.3
	2 PLC ±0.2
	3 PLC ±-
	4 PLC ±-
	ANGLES ±-
MATERIAL	FINISH
SEE NOTE	SEE NOTE

DWN	28APR2016
FENCER YU	
CHK	28APR2016
KOBBY ZHAO	
APVD	28APR2016
XIANG XU	
PRODUCT SPEC	SEE TABLE
APPLICATION SPEC	-
WEIGHT	3.17 g
CUSTOMER DRAWING	

2232261-3	2.20	2.60	2.60	108-137412
PART NUMBER	DIM A	DIM B	DIM C	PRODUCT SPEC
TE Connectivity				
NAME 1394_A RECEPTACLE UP RIGHT R/A THRU HOLE TYPE				
SIZE	CAGE CODE	DRAWING NO	RESTRICTED TO	
A3	00779	C-2232261		
SCALE 3:1		SHEET 4 OF 6		REV A5

P	LTR	DESCRIPTION	DATE	DWN	APVD
-	-	SEE SHEET 1	-	-	-

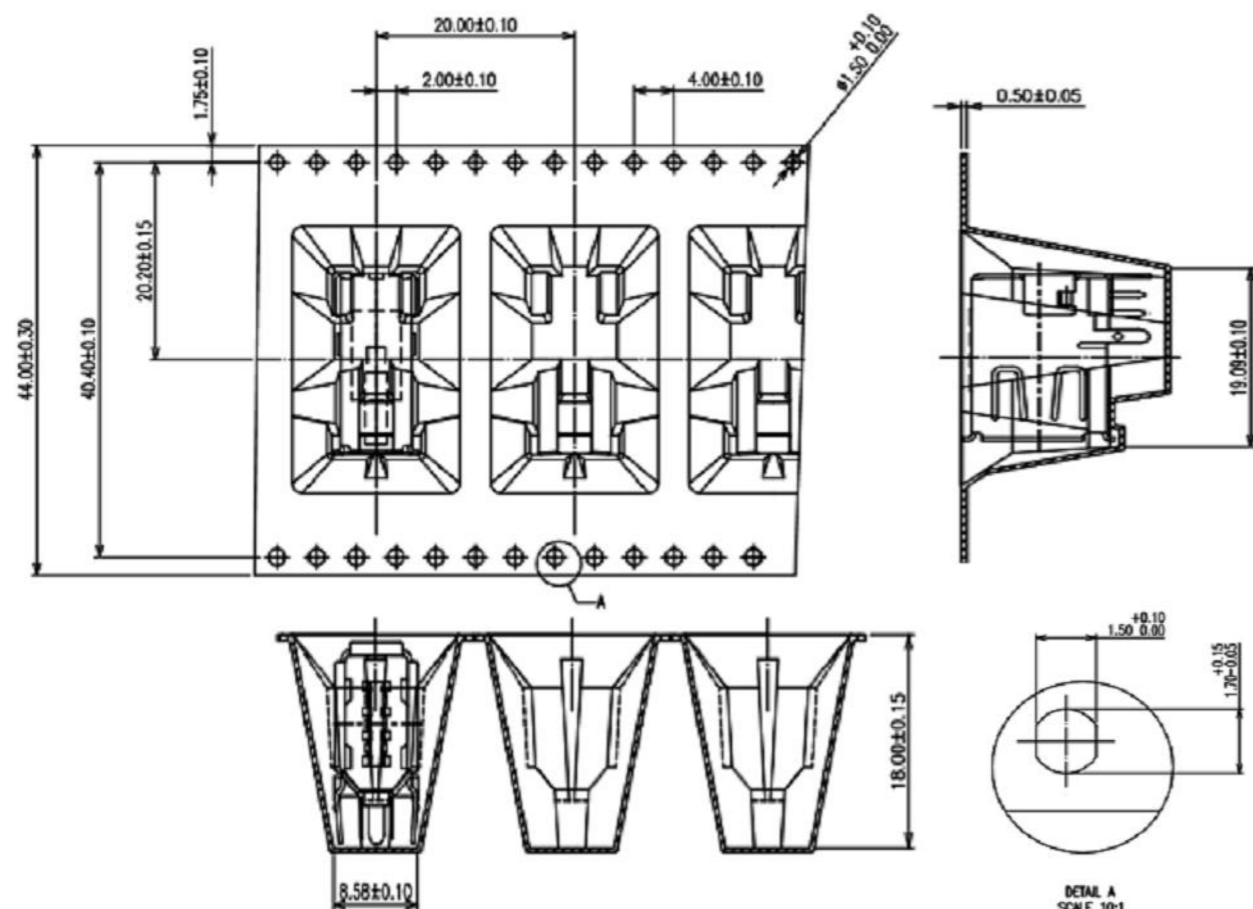

- NOTE:
1. USED ON 1394 SERIES
 2. PACKAGE 150PCS/REEL, 900PCS/BOX
 3. MATERIAL: BLACK CONDUCTIVE POLYSTYRENE
 4. APPLICABLE DOCUMENT: EIA-481-D
 5. BEFORE UNREELING DIRECTION MUST HAVE 20PCS BLANK (400MM MIN)
 6. AFTER UNREELING DIRECTION MUST HAVE 9PCS BLANK (170MM MIN)

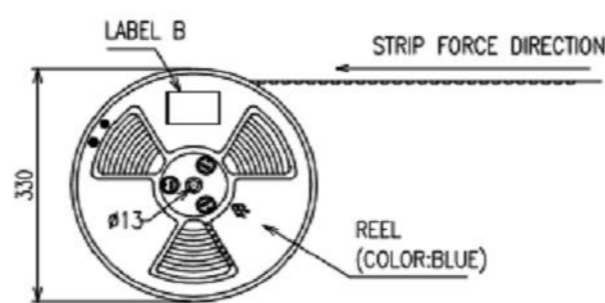
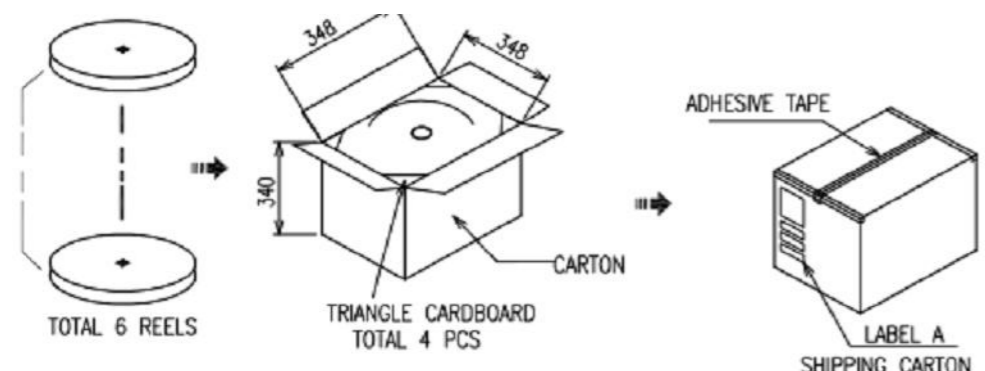
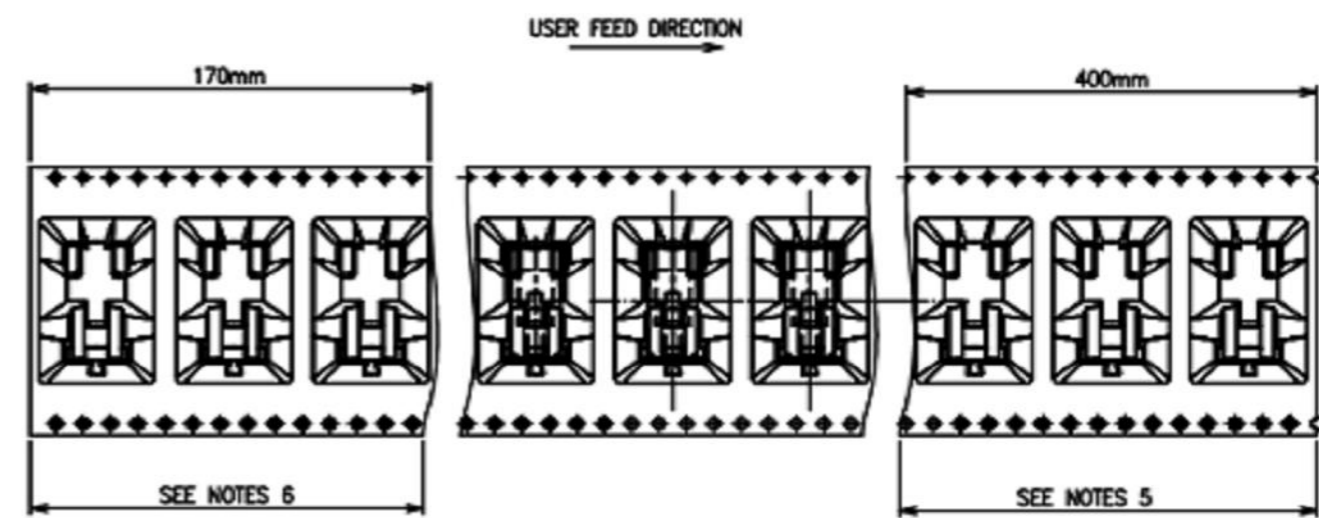

Part number: 2232261-3
Quantity: 150
Date code: ****
Rev: *
Country of origin: China

2232261-3

Part number: 2232261-3
Quantity: 900
Date code: ****
Rev: *
Country of origin: China

2232261-3

LABEL DETAIL B

LABEL DETAIL A

2232261-3	4.51Kg	2.92Kg	150	6	900PCS
PART NUMBER	GROSS WEIGHT	NET WEIGHT	PCS/REEL	REEL/ INNER BOX	QUANTITY

THIS DRAWING IS A CONTROLLED DOCUMENT.

DIMENSIONS: mm	TOLERANCES UNLESS OTHERWISE SPECIFIED:	DWN FENCER YU 28APR2016	TE Connectivity NAME 1394_A RECEPTACLE UP RIGHT R/A THRU HOLE TYPE SIZE CAGE CODE DRAWING NO RESTRICTED TO A300779 C-2232261
	0 PLC ±	CHK KOBBY ZHAO 28APR2016	
	1 PLC ±0.3	APVD XIANG XU 28APR2016	
	2 PLC ±0.2	PRODUCT SPEC SEE TABLE	
MATERIAL	FINISH	APPLICATION SPEC -	WEIGHT 3.17 g
SEE NOTE	SEE NOTE	CUSTOMER DRAWING	SCALE 3:1 SHEET 5 OF 6 REV A5

P	LTR	DESCRIPTION	DATE	DWN	APVD
-	-	SEE SHEET 1	-	-	-

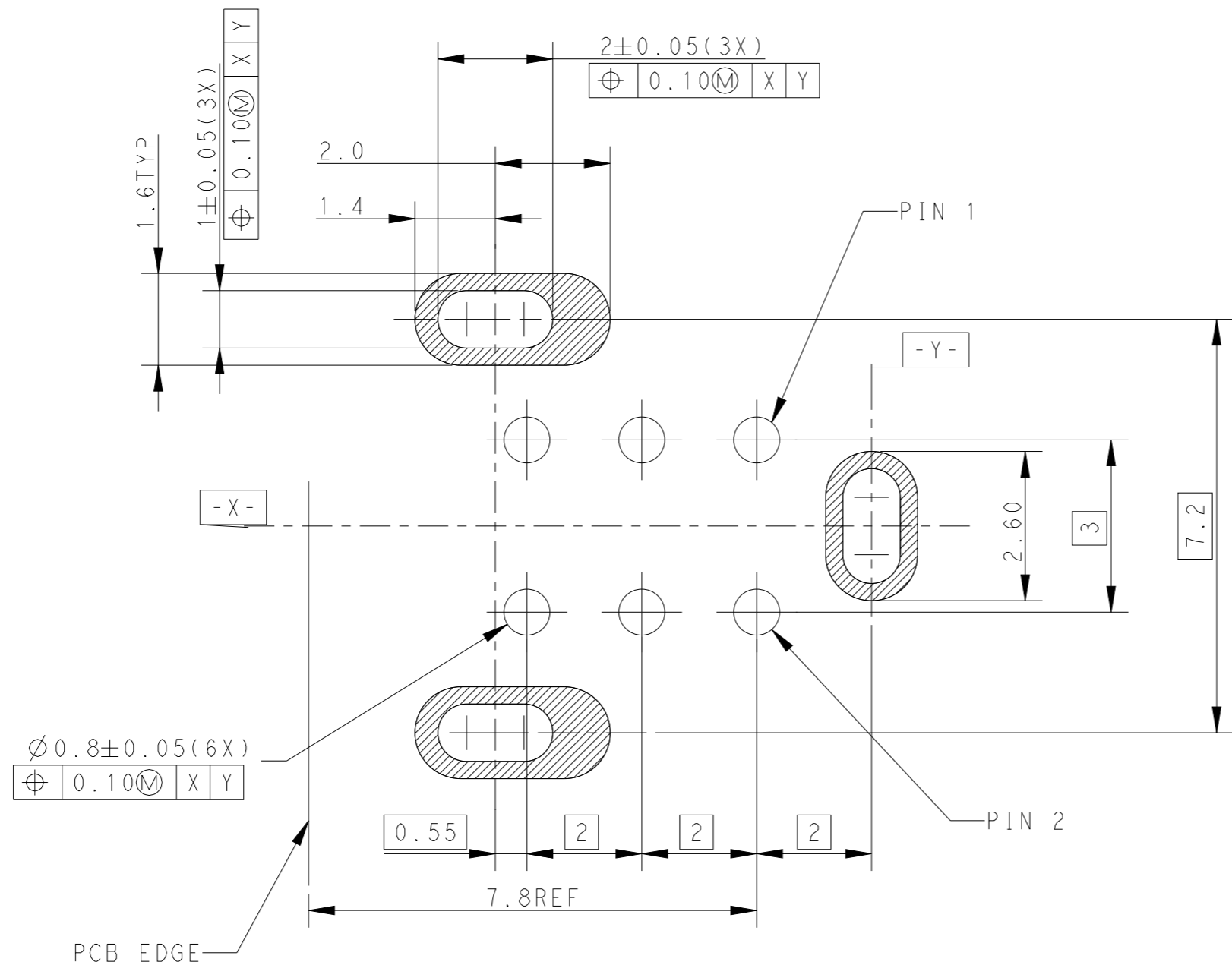

RECOMMENDED PCB LAYOUT

THIS DRAWING IS A CONTROLLED DOCUMENT.		DWN 28APR2016 FENCER YU		 TE Connectivity	
DIMENSIONS: mm		CHK 28APR2016 KOBBY ZHAO			
TOLERANCES UNLESS OTHERWISE SPECIFIED:		APVD 28APR2016 XIANG XU		NAME 1394_A RECEPTACLE UP RIGHT R/A THRU HOLE TYPE	
0 PLC ±- 1 PLC ±0.3 2 PLC ±0.2 3 PLC ±- 4 PLC ±- ANGLES ±-		PRODUCT SPEC SEE TABLE		RESTRICTED TO	
MATERIAL SEE NOTE		FINISH SEE NOTE		APPLICATION SPEC -	
		WEIGHT 3.17 g		SIZE A3	
		CUSTOMER DRAWING		CAGE CODE 00779	
				DRAWING NO C-2232261	
				SCALE 3:1	
				SHEET 6 OF 6	
				REV A5	