

REVISIONS					
P	LTR	DESCRIPTION	DATE	DWN	APVD
1		INITIAL RELEASE	17JUL2023	JG	Q,XI

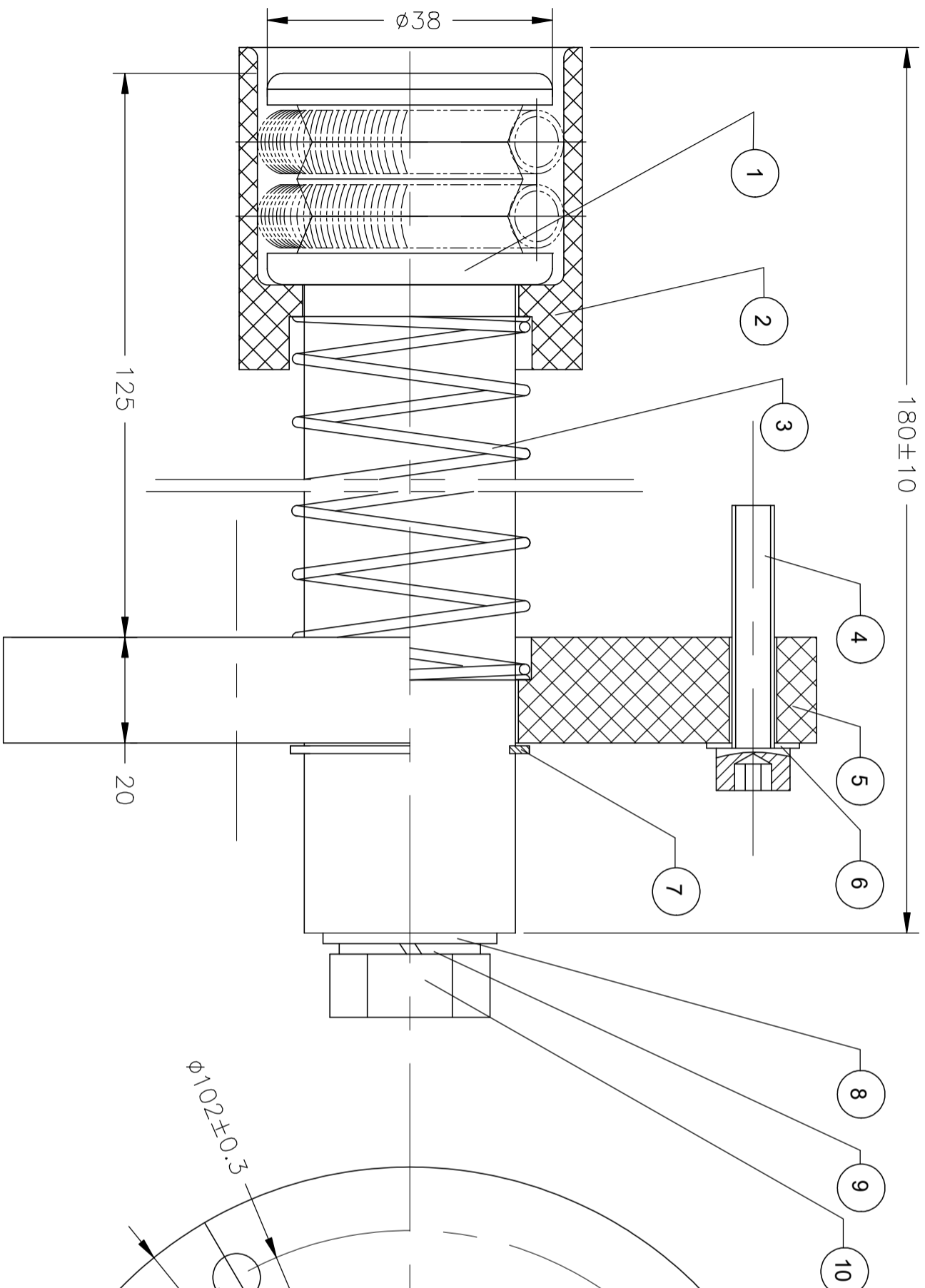

QTY	PART NO.	DESCRIPTION	ITEM NO.
1	2197612-5	Contact spring (TE provided)	11
1	GB/T581	M12x30 Hex Bolts	10
1	GB/T93	Ø12 spring washers	9
1	GB/97.2	Ø12 flat washers	8
1	GB/T894.1	Shaft Circlips	7
3	GB/T93	Ø8 spring washers	6
1	2259074-1	MVCA-RPIT-2-Flange	5
3	GB/T70	M8x45 Hex screw	4
1	2259073-1	MVCA-RPIT-2-Spring	3
1	2259072-1	MVCA-RPIT-2-PS	2
1	2259071-1	MVCA-RPIT-2-ROD	1

2259070-1	MVCA-RPIT-2-CTC	450 g
PART NO.	DESCRIPTION	WEIGHT

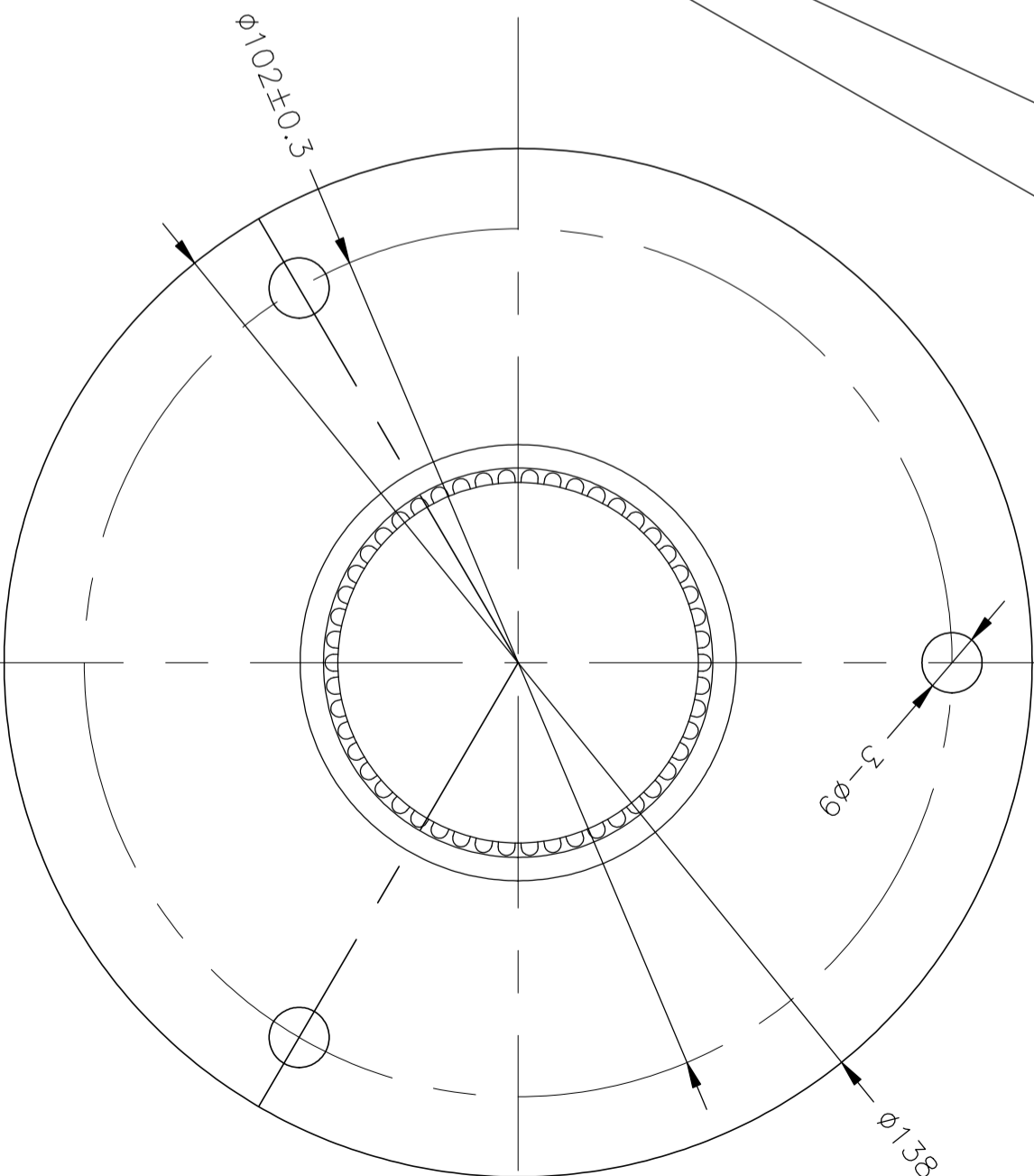

THIS DRAWING IS A CONTROLLED DOCUMENT.

DIMENSIONS:

mm



TOLERANCES UNLESS OTHERWISE SPECIFIED:

0	PLC	±	±
1	PLC	±	±
2	PLC	±	±
3	PLC	±	±
4	PLC	±	±
ANGLES		±	±
FINISH		±	±

DWN J GODWIN

CHK Q. IYV

APVD Q.XIANGMING

PRODUCT SPEC

APPLICATION SPEC

WEIGHT

450g

CUSTOMER DRAWING

17JUL2023

17JUL2023

17JUL2023

17JUL2023

17JUL2023

17JUL2023

17JUL2023

17JUL2023



TE Connectivity

MVCA-RPIT-2-CTC

NAME

SIZE

CAGE CODE

DRAWING NO

A300779

2259070

SCALE

1:1

SHEET

1 of 1